

THEORY OF POLYNOMIALS WITH PRESCRIBED SYMMETRY

JESSICA GATICA C.

A thesis submitted in partial fulfillment of
the requirements for the degree of
Doctor of Mathematics

Institute of Mathematics and Physics
University of Talca



NOVEMBER 2014

CONTENTS

1	Introduction	1
1.1	Quantum Sutherland system	1
1.2	Symmetric Jack polynomials and their clustering	2
1.3	Jack polynomials with prescribed symmetry	4
1.4	Non-symmetric Macdonald polynomials and Macdonald polynomials with prescribed symmetry	6
1.5	Main results	8
2	Preliminaries	14
2.1	Compositions, partitions, and superpartitions	14
2.2	Symmetric polynomials	21
2.3	Non-symmetric Jack polynomials	24
2.4	Jack polynomials with prescribed symmetry	27
3	Regularity and uniqueness properties at $\alpha = -(k + 1)/(r - 1)$	40
3.1	More on admissible superpartitions	40
3.2	Regularity for non-symmetric Jack polynomials	41
3.3	Regularity for Jack polynomials with prescribed symmetry	45
3.4	Uniqueness for Jack polynomials with prescribed symmetry	49
3.5	Uniqueness for non-symmetric Jack polynomials	54
4	Clustering properties	63
4.1	Definition clustering property	63
4.2	Clustering properties for $k = 1$	64
4.3	Translation invariance	73
4.3.1	Generators of translation	73
4.3.2	General invariance	78

4.3.3	Special cases of invariance	87
4.4	The clustering condition for $k > 1$	92
5	Macdonald polynomials with prescribed symmetry	99
5.1	Non-symmetric Macdonald Polynomials	99
5.2	Macdonald polynomials with prescribed symmetry	102
5.3	Clustering properties	110
5.3.1	Zeros of the non-symmetric Macdonald polynomials	111
5.3.2	Clustering properties for $k = 1$	112
5.3.3	Clusterings properties for $k \geq 1$	116
A	Recursive formula for non-symmetric Jack polynomials	122
B	Triangularity of Jack polynomials with prescribed symmetry	123
C	Sets of cells associated to superpartitions	125
D	Clustering for non-symmetric Jack polynomials	127
E	Examples of admissible and invariant superpartitions	129
F	Recursive formula for non-symmetric Macdonald polynomials	132
G	Expansion of Macdonald polynomials	133
	BIBLIOGRAPHY	136

AGRADECIMIENTOS

Esta tesis es el resultado de años de estudio y apoyo constante de mi familia, amigos, profesores y director. Es por esto, que agradezco en primer lugar, a mis padres, Margoth y José, por darme las oportunidades para continuar la educación superior. Además, agradezco a Karín y Cristian, quienes han vivido conmigo todos estos años, y han estado de forma incondicional a mi lado. Del mismo modo, agradezco a Paula, que me brindó su apoyo y amistad desde que nos conocimos.

Me gustaría agradecer a mis profesores de pre-grado, en especial a Yuri Haraguchi, Ivo Basso y Roberto Cabrales, quienes me motivaron a continuar estudios de post-grado y creyeron en que podría egresar exitosamente de estos programas. Agradezco a mis profesores de post-grado, en especial a Luc Lapointe y Stephen Griffeth por las discusiones interesantes y útiles comentarios para el primer artículo. Y de forma especial agradezco a Ricardo Baeza, por sus comentarios y por el tiempo dedicado a ayudarme a mejorar la redacción de la presente tesis.

Quisiera dar mis más sinceros agradecimientos a mi Director Patrick Desrosiers, quien sin ser mi profesor, me aceptó como estudiante de doctorado. Agradezco el proyecto de investigación, las retroalimentaciones continuas, las discusiones interesantes, entretenidas y beneficiosas, y las correcciones realizadas con el fin de potenciarme como investigadora independiente. Agradezco su confianza y por sobre todo agradezco su tiempo.

Me gustaría agradecer finalmente al Gobierno de Chile, CONICYT, y Universidad de Talca, por el apoyo financiero otorgado para llevar a cabo este proyecto.

RESUMEN

En esta tesis vamos a estudiar dos tipos de polinomios en N variables con simetría prescrita: los polinomios de Jack con simetría prescrita y los polinomios de Macdonald con simetría prescrita.

Los polinomios de Jack con simetría prescrita, se obtienen de los polinomios de Jack no simétricos (indexados por composiciones formadas por dos particiones) mediante una antisimetrización o simetrización con respecto a dos conjuntos disjuntos de variables. Mostraremos las propiedades que caracterizan estos polinomios, tales como: triangularidad en ciertas bases monomiales y su unicidad como funciones propias de operadores diferenciales de tipo Calogero-Sutherland. Además, mostraremos algunos resultados obtenidos sobre las propiedades de agrupación bajo la especialización del parámetro α de estos polinomios, las cuales corresponden a la factorización que resulta tras considerar un conjunto de variables e igualarlas a un parámetro adicional.

Similarmente, los polinomios de Macdonald con simetría prescrita, se obtienen de los polinomios de Macdonald no simétricos, mediante un proceso de t -antisimetrización o t -simetrización con respecto a dos conjuntos disjuntos de variables. Los polinomios de Macdonald son una generalización de los polinomios de Jack y es por esto que algunas propiedades de los polinomios de Jack con simetría prescrita se obtienen como consecuencia de propiedades de los Macdonald con simetría prescrita. En el último capítulo mostraremos algunos resultados obtenidos sobre las propiedades de agrupación bajo la especialización de los parámetros q y t de estos polinomios, las cuales están basadas en las condiciones de ceros de los polinomios de Macdonald no simétricos.

CHAPTER 1

INTRODUCTION

This thesis is mainly concerned with two families of orthogonal polynomials in N variables: the Jack polynomials with prescribed symmetry and the Macdonald polynomials with prescribed symmetry.

In this introduction, we define these mathematical objects and explain why they are so important to mathematical physics. We pay particular attention to new algebraic properties of the Jack and Macdonald polynomials with prescribed symmetry, known as clustering properties, that were obtained in the course of the doctorate.

1.1 QUANTUM SUTHERLAND SYSTEM

We study properties of polynomials in many variables that provide the wave functions for the Sutherland model with exchange term, which is a famous quantum mechanical many-body problem in mathematical physics. This model describes the evolution of N particles interacting on the unit circle.

To be more explicit, let $\phi_j \in \mathbb{T} = [0, 2\pi)$ be the variable that describes the position of the j th particle in the system. Let also the operator $K_{i,j}$ act on any multivariate function of ϕ_1, \dots, ϕ_N by interchanging the variables ϕ_i and ϕ_j . Finally, suppose that g is some positive real number. Then, the Sutherland model, with coupling constant g and exchange terms $K_{i,j}$, is defined via the following Schrodinger operator acting on $L^2(\mathbb{T}^N)$ [59, 12]:

$$H = - \sum_{i=1}^N \frac{\partial^2}{\partial \phi_i^2} + \frac{1}{2} \sum_{i \neq j} \frac{1}{\sin^2(\frac{\phi_i - \phi_j}{2})} g(g - K_{i,j}). \quad (1.1.1)$$

When acting on symmetric functions, the operators $K_{i,j}$ can be replaced by the identity and the standard Sutherland model is recovered [64]. The latter is intimately related to Random Matrix Theory [33]. For $K_{i,j} \neq 1$, the operator H was used for describing systems of particles with spin (see for instance [42, 60]).

Up to a multiplicative constant, there is a unique eigenfunction Ψ_0 of H with minimal eigenvalue E_0 [41]. Explicitly, defining $\alpha = g^{-1}$ and $x_j = e^{i\phi_j}$, where $i = \sqrt{-1}$, we have

$$\Psi_0 = \prod_{1 \leq i < j \leq N} |x_i - x_j|^{1/\alpha}, \quad E_0 = \frac{N(N^2 - 1)}{12\alpha^2}. \quad (1.1.2)$$

The operator H admits eigenfunctions of the form $\Psi(x) = \Psi_0(x)P(x)$, where $P(x)$ is a polynomial eigenfunction of the operator $D = \Psi_0^{-1} \circ (H - E_0) \circ \Psi_0$, that is,

$$\begin{aligned} D = & \sum_{i=1}^N \left(x_i \frac{\partial}{\partial x_i} \right)^2 + \frac{2}{\alpha} \sum_{1 \leq i < j \leq N} \frac{x_i x_j}{x_i - x_j} \left(\frac{\partial}{\partial x_i} - \frac{\partial}{\partial x_j} \right) \\ & - \frac{2}{\alpha} \sum_{1 \leq i < j \leq N} \frac{x_i x_j}{(x_i - x_j)^2} (1 - K_{i,j}) + \frac{N-1}{\alpha} \sum_{i=1}^N x_i \frac{\partial}{\partial x_i}. \end{aligned} \quad (1.1.3)$$

1.2 SYMMETRIC JACK POLYNOMIALS AND THEIR CLUSTERING

Let $\mathcal{S}_{\{1, \dots, N\}}$ denote the ring of symmetric polynomials in N variables with coefficients in the field of rational functions in the formal parameter α , denoted by $\mathbb{C}(\alpha)$. Any homogeneous element of degree n in $\mathcal{S}_{\{1, \dots, N\}}$ can be indexed by a partition of n , which is sequence $\lambda = (\lambda_1, \dots, \lambda_N)$ such that $\lambda_1 \geq \dots \geq \lambda_N \geq 0$ and $\lambda_1 + \dots + \lambda_N = n$. In general, we only write the non-zero elements of the partition. Partitions are often sorted with the help of the following partial order, called the dominance order:

$$\lambda \geq \mu \quad \iff \quad \sum_{i=1}^k \lambda_i \geq \sum_{i=1}^k \mu_i, \quad \forall k,$$

where it is assumed that both partitions have the same degree n . A convenient way to write a symmetric polynomial consists in giving its linear expansion in the basis of monomial symmetric functions $\{m_\lambda\}_\lambda$, where

$$m_\lambda = x_1^{\lambda_1} \cdots x_N^{\lambda_N} + \text{distinct permutations.}$$

Since Stanley's seminal work [62], we know that the symmetric Jack polynomial associated to the partition λ , denoted $P_\lambda = P_\lambda(x; \alpha)$, is the unique symmetric eigenfunction of (1.1.3) that is monic and triangular in the monomial basis, where the triangularity is taken with respect to the dominance ordering. In symbols, P_λ is the unique element of $\mathcal{S}_{\{1, \dots, N\}}$ that satisfies the following two properties:

$$(A1) \quad P_\lambda = m_\lambda + \sum_{\mu < \lambda} c_{\lambda, \mu}(\alpha) m_\mu,$$

$$(A2) \quad DP_\lambda = \varepsilon_\lambda(\alpha) P_\lambda,$$

where $\varepsilon_\lambda(\alpha)$ is the eigenvalue and will be given later in Lemma 2.1.1.

It is worth stressing that uniqueness of the polynomial satisfying (A1) and (A2) remains valid if we suppose that α is a positive real or an irrational (see Section 2.1). However, when α is a negative rational number, the uniqueness is generally lost, and moreover the polynomials could have poles in this case. Nevertheless, Feigin, Jimbo, Miwa, and Mukhin [31] showed that for k and $r - 1$ positive integers with $\gcd(k + 1, r - 1) = 1$, and for a given partition $\lambda = (\lambda_1, \dots, \lambda_N)$ satisfying

$$\lambda_i - \lambda_{i+k} \geq r \quad \forall 1 \leq i \leq N - k \quad (1.2.1)$$

the Jack polynomial indexed by the partition λ is not only regular at certain negative fractional values of α but also exhibits remarkable vanishing properties when some variables coincide. Those partitions were called (k, r, N) -admissible partitions.

Proposition 4.1 in [31] states that if λ is (k, r, N) -admissible and α is equal to

$$\alpha_{k,r} = -\frac{k+1}{r-1}, \quad (1.2.2)$$

then $P_\lambda(x; \alpha)$ is regular and vanishes when $k + 1$ variables coincide, that is, $P_\lambda(x; \alpha_{k,r})|_{x_{N-k} = \dots = x_N} = 0$. Bernevig and Haldane [13] later used the above vanishing property for modelling fractional quantum Hall states with Jack polynomials. They moreover conjectured that the Jack polynomials indexed by (k, r, N) -admissible partitions satisfy the following clustering property, which gives a more precise statement about how the polynomials vanish.

In general, we say that a symmetric polynomial P admits a cluster of size k and order r ($k, r \in \mathbb{Z}_+$), if it vanishes to order at least r when $k + 1$ of the variables are equal, that is,

$$P(x_1, \dots, x_{N-k}, \overbrace{z, \dots, z}^{k \text{ times}}) = \prod_{j=1}^{N-k} (x_j - z)^r Q(x_1, \dots, x_{N-k}, z) \quad (1.2.3)$$

for some polynomial Q in $N - k + 1$ variables.

Baratta and Forrester [8] proved that the Jack polynomials (along with other symmetric polynomials such as Hermite and Laguerre) indexed with $(1, r, N)$ -admissible partitions satisfy equation (1.2.3) at $\alpha_{1,r}$. The same authors also proved clustering properties for $k > 1$ in the case of partitions associated to translationally invariant Jack polynomials [37]. Very recently, Berkesch, Griffeth, and Sam proved the general $k \geq 1$ clustering property for Jack polynomials [11]. Their method was based on the representation theory of the rational Cherednik algebra. In fact, reference [11] also contains the proof for more general vanishing properties in the case of many clusters, some of them having been conjectured earlier in [13].

1.3 JACK POLYNOMIALS WITH PRESCRIBED SYMMETRY

The operator D has polynomial eigenfunctions of different symmetry classes. As we have mentioned above, the symmetric Jack polynomials $P_\lambda(x; \alpha)$ are eigenfunctions of D , as well the non-symmetric Jack polynomials, which were introduced by Opdam [58]. The non-symmetric Jack polynomials, denoted by $E_\eta(x; \alpha)$, where η is a composition, can be defined as the common eigenfunctions of the commuting set $\{\xi_j\}_{j=1}^N$, where each ξ_j is a first order differential operator, often called a Cherednik operator (see eq. (2.3.1)).

However, as first shown by Baker and Forrester [4], one can use the latter polynomials to construct orthogonal eigenfunctions of D whose symmetry property interpolates between the completely symmetric Jack polynomials, $P_\lambda(x; \alpha)$, and the completely antisymmetric ones, sometimes denoted by $S_\lambda(x; \alpha)$. In other words, there exist eigenfunctions that are symmetric in some given subsets of $\{x_1, \dots, x_N\}$ and antisymmetric in other subsets, all subsets of variables being

mutually disjoint. Such eigenfunctions are called Jack polynomials with prescribed symmetry and were considered in [4, 43, 27, 1, 34]. In this thesis, we study systematically the Jack polynomials with prescribed symmetry for two sets of variables.

Before given the precise definition of the Jack polynomials with prescribed symmetry, let us introduce some more notation. For a given set $K = \{k_1, \dots, k_M\} \subseteq \{1, \dots, N\}$, let Asym_K and Sym_K respectively denote the antisymmetrization and the symmetrization operators with respect to the variables x_{k_1}, \dots, x_{k_M} . If $f(x)$ is an element of $\mathcal{V} = \mathbb{C}(\alpha)[x_1, \dots, x_N]$, then $\text{Sym}_K f(x)$ belongs to \mathcal{S}_K , the submodule of \mathcal{V} whose elements are polynomials symmetric in x_{k_1}, \dots, x_{k_M} . Similarly, $\text{Asym}_K f(x)$ belongs to \mathcal{A}_K , the submodule of polynomials antisymmetric in x_{k_1}, \dots, x_{k_M} .

So, for a given positive integer $m \leq N$, set $I = \{1, \dots, m\}$ and $J = \{m+1, \dots, N\}$.¹ Let $\lambda = (\lambda_1, \dots, \lambda_m)$ and $\mu = (\mu_1, \dots, \mu_{N-m})$ be partitions. The monic Jack polynomial with prescribed symmetry of type antisymmetric-symmetric (AS for short) and indexed by the ordered set

$$\Lambda = (\lambda_1, \dots, \lambda_m; \mu_1, \dots, \mu_{N-m})$$

is defined as follows:

$$P_{\Lambda}^{\text{AS}}(x; \alpha) = c_{\Lambda}^{\text{AS}} \text{Asym}_I \text{Sym}_J E_{\eta}(x; \alpha),$$

where η is a composition equal to $(\lambda_m, \dots, \lambda_1, \mu_{N-m}, \dots, \mu_1)$ while the normalization factor c_{Λ}^{AS} is such that the coefficient of $x_1^{\lambda_1} \cdots x_m^{\lambda_m} x_{m+1}^{\mu_1} \cdots x_N^{\mu_{N-m}}$ in $P_{\Lambda}^{\text{AS}}(x; \alpha)$ is equal to one. Other types of Jack polynomials are defined similarly:

$$P_{\Lambda}^{\text{AA}}(x; \alpha) = c_{\Lambda}^{\text{AA}} \text{Asym}_I \text{Asym}_J E_{\eta}(x; \alpha),$$

$$P_{\Lambda}^{\text{SA}}(x; \alpha) = c_{\Lambda}^{\text{SA}} \text{Sym}_I \text{Asym}_J E_{\eta}(x; \alpha),$$

$$P_{\Lambda}^{\text{SS}}(x; \alpha) = c_{\Lambda}^{\text{SS}} \text{Sym}_I \text{Sym}_J E_{\eta}(x; \alpha).$$

The coefficients c_{Λ} will be given in equations (2.4.12)–(2.4.15).

¹The above definition could be obviously generalized by considering $I = \{i_1, \dots, i_m\}$ and $J = \{j_1, \dots, j_{N-m}\}$ as two general disjoint sets such that $I \cup J = \{1, \dots, N\}$. However, this would make the presentation more intricate. One easily goes from one definition to the other by permuting the variables.

The above polynomials belong to $\mathcal{A}_I \otimes \mathcal{S}_J$, $\mathcal{A}_I \otimes \mathcal{A}_J$, $\mathcal{S}_I \otimes \mathcal{A}_J$, $\mathcal{S}_I \otimes \mathcal{S}_J$ respectively, which are all vector spaces over $\mathbb{C}(\alpha)$. These spaces are spanned by monomials, denoted by m_Λ , each of them being indexed by an ordered pair of partitions $\Lambda = (\lambda_1, \dots, \lambda_m; \mu_1, \dots, \mu_{N-m})$. Analogously to the Jack polynomials with prescribed symmetry, the monomials are defined by the action of Asym_K and Sym_K , where K is either I or J , on the non-symmetric monomial $x_1^{\lambda_1} \cdots x_m^{\lambda_m} x_{m+1}^{\mu_1} \cdots x_N^{\mu_{N-m}}$. See Section 2.4 for more details.

The case AS is very special since the polynomials $P_\Lambda^{\text{AS}}(x; \alpha)$ can be used to solve the supersymmetric Sutherland model [22], which is a generalization of the model (1.1.1), and that moreover involves Grassmann variables. In this context, the indexing set $\Lambda = (\lambda_1, \dots, \lambda_m; \mu_1, \dots, \mu_{N-m})$ is called a superpartition – while that in [19] it could be called an overpartition – where $\lambda = (\lambda_1, \dots, \lambda_m)$ is also strictly decreasing. The correct diagrammatic representation of superpartitions, first given in [24], proved to be very useful. It allowed, for instance, the derivation of a very simple evaluation formula for $P_\Lambda^{\text{AS}}(x; \alpha)$ [25], which in turn lead to the first results regarding the clustering properties of these polynomials [26]. We adopt here a slightly more general point of view for superpartitions.

For us, a superpartition is an ordered set of positive integers

$$\Lambda = (\Lambda_1, \dots, \Lambda_m; \Lambda_{m+1}, \dots, \Lambda_N).$$

We say that Λ has bi-degree $(n|m)$, if it satisfies the following conditions:

$$\Lambda_1 \geq \cdots \geq \Lambda_m \geq 0 \quad \Lambda_{m+1} \geq \cdots \geq \Lambda_N \geq 0 \quad \sum_{i=1}^N \Lambda_i = n.$$

1.4 NON-SYMMETRIC MACDONALD POLYNOMIALS AND MACDONALD POLYNOMIALS WITH PRESCRIBED SYMMETRY

The non-symmetric Macdonald polynomials were introduced two decades ago by Opdam [58], Macdonald [54] and Cherednik [17] in the context of the study of Affine Hecke algebras and orthogonal polynomials.

We denote the monic non-symmetric Macdonald polynomial indexed by the composition $\eta = (\eta_1, \dots, \eta_N) \in \mathbb{N}_0^N$ as $E_\eta(x; q, t)$, where $x = x_1, \dots, x_N$ are

the variables, and q and t are formal parameters. The non-symmetric Macdonald polynomials are considered the q -generalization of the non-symmetric Jack polynomials, due to the fact that they can be recovered from the non-symmetric Macdonald polynomials through the specialization $q = t^\alpha$ when $t \rightarrow 1$, i.e.

$$E_\eta(x; q, t)|_{q=t^\alpha} \longrightarrow E_\eta(x; \alpha), \quad \text{when } t \rightarrow 1.$$

The non-symmetric Macdonald polynomials were extensively studied in several articles, including [6, 35, 55, 56]. On the contrary, their clustering properties were only studied in [8], [28] and [39].

The Macdonald polynomials with prescribed symmetry were introduced recently by Baker, Dunkl and Forrester [1]. These polynomials were later studied by Baratta in [7] and [9] (Doctoral Thesis).

By using the Demazure-Lusztig operators, we generalize the symmetrization and anti-symmetrization operators to new operators, called t -symmetrization and t -antisymmetrization. Acting with the operators t -symmetrization and t -antisymmetrization on disjoint subsets of variables on non-symmetric Macdonald polynomials, we build the Macdonald polynomials with prescribed symmetry. The construction method of the Macdonald polynomials with prescribed symmetry is thus similar to that of the Jack polynomials with prescribed symmetry. In fact, both families of polynomials can be characterized as eigenfunctions of generalizations of the CSM.

Particular families of Macdonald polynomials with prescribed symmetry are: the symmetric Macdonald polynomial (they are obtained through a process of t -symmetrization on non-symmetric Macdonald polynomials), and the t -antisymmetric Macdonald polynomial (obtained through a process of t -antisymmetrization on non-symmetric Macdonald polynomials).

In this thesis, we restrict our study to two sets of variables. For a given positive integer $m \leq N$, set $I = \{1, \dots, m\}$ and $J = \{m+1, \dots, N\}$. Let also $\lambda = (\lambda_1, \dots, \lambda_m)$ and $\mu = (\mu_1, \dots, \mu_{N-m})$ be partitions. For us, the monic Macdonald polynomial with prescribed symmetry of type t -antisymmetric - t -symmetric

(denoted AS) and indexed by the ordered set $\Lambda = (\lambda_1, \dots, \lambda_m; \mu_1, \dots, \mu_{N-m})$ is defined as

$$P_\Lambda^{\text{AS}}(x; q, t) = c_\Lambda^{\text{AS}} U_I^- U_J^+ E_\eta(x; q, t),$$

where η is a composition equal to $(\lambda_1, \dots, \lambda_m, \mu_1, \dots, \mu_{N-m})$, c_Λ^{AS} is the factor of normalization and

$$U_I^+ = \sum_{\sigma \in S_m} T_\sigma, \quad U_J^- = \sum_{\sigma \in S_{N-m}} \left(\frac{-1}{t}\right)^{l(\sigma)} T_\sigma. \quad (1.4.1)$$

Other types of Macdonald polynomials are defined similarly:

$$P_\Lambda^{\text{AA}}(x; q, t) = c_\Lambda^{\text{AA}} U_I^- U_J^- E_\eta(x; q, t),$$

$$P_\Lambda^{\text{SA}}(x; q, t) = c_\Lambda^{\text{SA}} U_I^+ U_J^- E_\eta(x; q, t),$$

$$P_\Lambda^{\text{SS}}(x; q, t) = c_\Lambda^{\text{SS}} U_I^+ U_J^+ E_\eta(x; q, t)$$

with

$$U_I^- = \sum_{\sigma \in S_m} \left(\frac{-1}{t}\right)^{l(\sigma)} T_\sigma \quad \text{and} \quad U_J^+ = \sum_{\sigma \in S_{N-m}} T_\sigma. \quad (1.4.2)$$

The AS case is special, because it can be also obtained from Macdonald superpolynomials (see [15]).

Baker, Dunkl and Forrester showed that the Macdonald polynomials with prescribed symmetry can be expressed as a linear combination of non-symmetric Macdonald polynomials. They gave the explicit formula for each one of the families of polynomials mentioned in the preceding paragraph. They proved their formulas for the cases AA and SA (see [1, Corollary 1]). Moreover, they proved a clustering property of the Macdonald polynomials with prescribed of type AS, which will be recalled in Proposition 5.3.10. Baratta conjectured a generalization of this property and proved a particular case: that of the Macdonald polynomial with prescribed symmetry whose indexing composition is formed by the concatenation of the partition $(0, \dots, 0)$ and δ a staircase partition (see [7]).

1.5 MAIN RESULTS

Our first aim in this thesis is to give a very simple characterization of Jack polynomials with prescribed symmetry that generalizes Properties (A1) and (A2).

To this end, we use the differential operators of Sekiguchi type:

$$S^*(u) = \prod_{i=1}^N (u + \xi_i) \quad \text{and} \quad S^\circledast(u, v) = \prod_{i=1}^m (u + \xi_i + \alpha) \prod_{i=m+1}^N (v + \xi_i), \quad (1.5.1)$$

where u and v are formal parameters. We often set $v = u$, since this case leads to simpler eigenvalues. It is a simple exercise to show that the symmetric Jack polynomial $P_\lambda(x; \alpha)$ is an eigenfunction of $S^*(u)$, with eigenvalue

$$\varepsilon_\lambda(\alpha, u) = \prod_{i=1}^N (u + \alpha \lambda_i - i + 1). \quad (1.5.2)$$

The same polynomial cannot be an eigenfunction of $S^\circledast(u, v)$, since the latter does not preserve $\mathcal{S}_{\{1, \dots, N\}}$. In fact, S^* and S^\circledast together preserve the spaces $\mathcal{A}_I \otimes \mathcal{S}_J$, $\mathcal{A}_I \otimes \mathcal{A}_J$, $\mathcal{S}_I \otimes \mathcal{A}_J$, and $\mathcal{S}_I \otimes \mathcal{S}_J$. They moreover serve as generating series for the conserved quantities of the Sutherland model with exchange terms:

$$S^*(u) = \sum_{d=0}^N u^{N-d} \mathcal{H}_d, \quad S^\circledast(u, v) = \sum_{d=0}^m \sum_{d'=0}^{N-m} u^{m-d} v^{N-m-d'} \mathcal{I}_{d,d'},$$

where all the operators \mathcal{H}_d and $\mathcal{I}_{d,d'}$ commute among themselves and preserve the spaces mentioned above. They are given by

$$\mathcal{H}_d = \sum_{i=1}^N \xi_i^d, \quad \mathcal{I}_{d,d'} = \sum_{i=1}^m \xi_i^d \sum_{i=m+1}^N \xi_i^{d'}.$$

Amongst them, the most important are

$$\mathcal{H} = \mathcal{H}_2 = \sum_{i=1}^N \xi_i^2, \quad \mathcal{I} = \mathcal{I}_1 = \sum_{i=1}^m \xi_i.$$

A simple computation shows that the operator D introduced in (1.1.3) is related to the operators \mathcal{H}_1 and \mathcal{H}_2 via

$$\mathcal{H}_2 + (N-1)\mathcal{H}_1 = \alpha^2 D + \frac{N(N-1)(2N-1)}{6}.$$

For a generic α , the differential operators \mathcal{H} and \mathcal{I} allow us to characterize the Jack polynomial with prescribed symmetry in a unique way. This can be achieved proving that Jack polynomials with prescribed symmetry are monic

and triangular with respect to the natural generalization of the monomial basis (where the triangularity is taken with respect to the dominance ordering of superpartitions), and also that they are eigenfunctions of the operators \mathcal{H} and \mathcal{I} simultaneously. This result is proved in Theorem 2.4.10 (see 2.4).

Our second aim is to prove clustering properties for Jack polynomials with prescribed symmetry. This properties hold only for negative fractional values of α . However, as is shown in Theorem 2.4.10, considering these values of α is not sufficient to get clustering properties, so we also have to restrict the set of possible polynomials to those that are indexed by admissible superpartitions (see definition 1.2.1).

Despite the difficulties mentioned above, we prove the uniqueness and the regularity of the Jack polynomials with prescribed symmetry under the specialization $\alpha = \alpha_{k,r}$. These properties are given in Proposition 3.3.4 and Theorem 3.4.4 respectively.

For the non-symmetric Jack polynomials indexed by special compositions formed by the concatenation of two partitions, we get similar results about the uniqueness under the specialization $\alpha = \alpha_{k,r}$ with $k = 1$ and r even. These results dependent on the admisibility condition satisfied by the indexing composition (see Theorems 3.5.2 and 3.5.3). The combination of these facts with Definition 1.3 allow us to prove the general clustering property in case $k = 1$ for Jack polynomials with prescribed symmetry. For the AS case, this property was first conjectured in [26]. More specifically (see Proposition 4.2.6), we prove that for a $(1, r, N)$ -admissible superpartition and $r \in \mathbf{Z}$ even,

$$P_{\Lambda}(x; \alpha_{1,r}) = \prod_{\substack{i,j \in K \\ i < j}} (x_i - x_j)^r Q(x),$$

where the set K depends on the type of symmetry considered, AS, SS, or SA respectively. While for the symmetry type AA,

$$P_{\Lambda}(x; \alpha_{1,r}) = \prod_{1 \leq i < j \leq N} (x_i - x_j)^{r-1} Q(x).$$

However, we have not been able to prove the following natural generalization of the above result: All Jack polynomials with prescribed symmetry, indexed

by (k, r, N) -admissible superpartitions, admit a cluster of size k and order r at $\alpha = \alpha_{k,r}$. Nevertheless, following an idea of Baratta and Forrester [8], we know that if a polynomial is invariant under translation and satisfies basic factorization and stability properties (see Lemma 2.4.4 and Proposition 2.4.6), then the polynomial can admit clusters of size $k > 1$. In the last part of Chapter 4.3 we turn our attention to the translationally invariant Jack polynomials with prescribed symmetry. Exploiting a result obtained in the context of the supersymmetric Sutherland model, only valid for the AS case, we find all strict and admissible superpartitions that lead to invariant polynomials (see Theorem 4.3.13).

Finally, Theorem 4.3.13 allows us to prove the $k > 1$ clustering property for translationally invariant Jack polynomials of type AS. This clustering property says that if P_{Λ}^{AS} is invariant under translation, then

$$P_{\Lambda}^{\text{AS}}(x_1, \dots, x_{N-k}, \overbrace{z, \dots, z}^{k \text{ times}}; \alpha_{k,r}) = \prod_{j=m+1}^{N-k} (x_j - z)^r Q(x_1, \dots, x_{N-k}, z)$$

for some polynomial Q (see Proposition 4.4.1).

Our third aim is to prove some algebraic properties of the Macdonald polynomials with prescribed symmetry, such as stability, regularity and clustering properties. To this end, we prove the result given in [1] according to which the Macdonald polynomials with prescribed symmetry can be expressed as a linear combination of non-symmetric Macdonald polynomials (see Proposition 5.2.3). These formulas allow us easily prove the regularity of each family of Macdonald polynomials with prescribed symmetry at the specialization $q^{r-1}t^{k+1} = 1$ (see Proposition 5.2.5).

Finally, we show some clustering properties for Macdonald polynomials with prescribed symmetry. We show these properties for Macdonald polynomials indexed by admissible superpartitions and specialized at $q^{r-1}t^{k+1} = 1$ with k and r positive integers and $\gcd(k+1, r-1) = 1$. Indeed, as explained in Subsection 5.3.3 and remark 5.3.13, it is not sufficient to consider only this specialization of the parameters, so we have to require an admissibility condition. In Theorems 5.3.6 and 5.3.9, we show that if $k = 1$ and if the superpartitions are weakly (k, r, N) -admissible for symmetry of type AS and AA or moderately (k, r, N) -admissible for symmetry of type SS and SA, then the corresponding Macdonald

admit clusters of order r .

However, for the case $k > 1$, we show that if we restrict the polynomials to those indexed by moderately (k, r, N) -admissible superpartitions, then these polynomials admit a cluster of size k and order $r-1$ at $q^{r-1}t^{k+1} = 1$ (see Proposition 5.3.14). As a direct consequence, we establish a "weak clustering property" for the Jack case: if Λ is any moderately (k, r, N) -admissible superpartition, then the Jack polynomial with prescribed symmetry $P_\Lambda(x; \alpha_{k,r})$ vanishes to order $r-1$ when $k+1$ variables among x_{m+1}, \dots, x_N coincide. We believe that for the Macdonald polynomials with prescribed symmetry (considering moderately admissible superpartitions), the vanishing order of the polynomials should be improved to reach r rather than $r-1$. We intend to prove this claim by using arguments from Representation Theory (in a similar way to the non-symmetric Jack polynomials, see [11]) or getting a characterization of the translationally invariant Macdonald polynomials with prescribed symmetry.

Other subjects of study closely related to the clustering properties studied here are the multiwheel conditions for non-symmetric Macdonald polynomials. We expect that these conditions can be generalized to the case of polynomials with prescribed symmetry, through the expansion of the Macdonald polynomials with prescribed symmetry in terms of non-symmetric Macdonald polynomials.

CHAPTER 2

PRELIMINARIES

In this chapter we give the definitions of compositions, partitions and superpartitions and some quantities associated to their diagrams. Also, we provide basic properties related to the order of partitions and superpartitions, which are required to characterize the Jack polynomials with prescribed symmetry.

The polynomials with prescribed symmetry studied in this chapter are called Jack polynomials with prescribed symmetry and were introduced by Baker, Dunkl and Forrester in [1]. However, the notation here used to define these polynomials, like the concept of superpartition and the order for superpartitions, were introduced in [22]. The algebraic properties of the Jack polynomials with prescribed symmetry (stability and regularity) are based on the properties of the non-symmetric Jack polynomials, which were given in [47]. Most of the results contained in this chapter have been published for the first time in [20, Section 2].

2.1 COMPOSITIONS, PARTITIONS, AND SUPERPARTITIONS

A composition is an ordered tuple $\eta = (\eta_1, \dots, \eta_N)$ of non-negative integers. We define the degree of η as

$$n = |\eta| := \sum_{i=1}^N \eta_i$$

and we say also that η is a composition of the integer n . The length of a composition is defined as the maximum i such that $\eta_i > 0$, and it is denoted by $\ell(\eta)$. To each composition is associated a diagram that contains $\ell(\eta)$ rows. The highest row, which is considered as the first one, contains η_1 boxes, the

second row, which is just below the first one, contains η_2 boxes, and so on, all boxes being left justified. The box located in the i th row and j th column of this diagram is called a cell and is denoted by (i, j) . Given a cell $s = (i, j)$ in the diagram associated to η , we let

$$\begin{aligned} a_\eta(s) &= \eta_i - j & l_\eta(s) &= \#\{k < i \mid j \leq \eta_k + 1 \leq \eta_i\} + \#\{k > i \mid j \leq \eta_k \leq \eta_i\} \\ a'_\eta(s) &= j - 1 & l'_\eta(s) &= \#\{k < i \mid \eta_k \geq \eta_i\} + \#\{k > i \mid \eta_k > \eta_i\} \end{aligned} \quad (2.1.1)$$

For example, for the composition $\eta = (6, 1, 4, 4, 2, 3)$ and the box $s = (4, 2)$ in the diagram

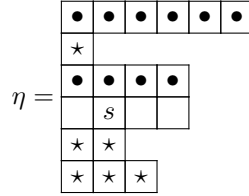

we have $a_\eta(s) = 2$, $a'_\eta(s) = 1$, $l_\eta(s) = 3$ y $l'_\eta(s) = 2$.

In particular, a partition $\lambda = (\lambda_1, \dots, \lambda_N)$ of n is a composition of n whose elements are decreasing: $\lambda_1 \geq \dots \geq \lambda_N \geq 0$. The number of non-zero elements in a partition λ is called the length and it is usually denoted by ℓ or $\ell(\lambda)$. To each partition is associated a diagram that contains ℓ rows. The diagrams of partitions are defined as the same diagrams for compositions. Given a partition λ , its conjugate λ' is obtained by reflecting λ 's diagram in the main diagonal. For instance, for $\lambda = (5, 3, 3, 1)$ the diagrams of λ and λ' are given by

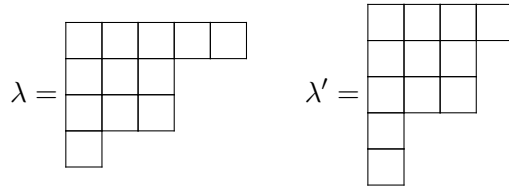

Given a cell $s = (i, j)$ in the diagram associated to λ , we set

$$a_\lambda(s) = \lambda_i - j \quad a'_\lambda(s) = j - 1 \quad l_\lambda(s) = \lambda'_j - i \quad l'_\lambda(s) = i - 1.$$

For example, for the partition $\lambda = (8, 6, 4, 3, 3, 3, 1)$ and the box $s = (2, 3)$ we

have the diagram

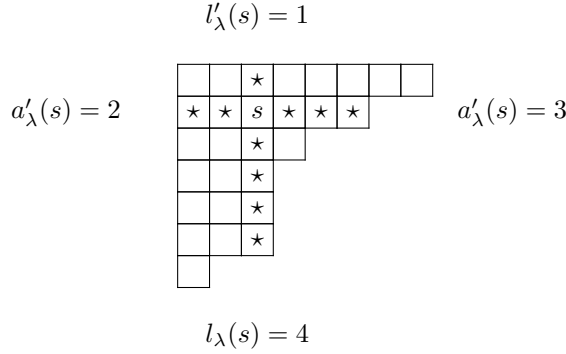

The quantities $a_\lambda(s), a'_\lambda(s), l_\lambda(s), l'_\lambda(s)$ are respectively called the arm-length, arm-colength, leg-length and leg-colength of s in λ 's diagram.

For two partitions we write $\mu \subseteq \lambda$ if $\mu_i \leq \lambda_i$ for all i (i.e. the diagram of μ is contained in the diagram of λ). If $\mu \subseteq \lambda$ we have a skew diagram λ/μ which consists of those boxes of λ which are not in μ . A skew diagram is said to be a vertical m -strip if λ/μ consists of m boxes, all of which are in distinct rows. For example, given $\lambda = (5, 3, 3, 1)$ and $\mu = (4, 3, 2, 1)$ then λ/μ is a vertical 2-strip. Diagrammatically we have

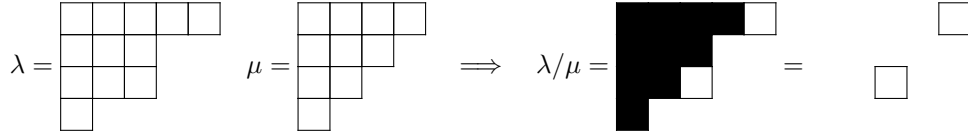

The first ordering we define on partitions is the lexicographic ordering \prec . The lexicographic ordering compares partitions of the same degree and is defined by $\mu \prec \lambda$ if the first non-vanishing difference $\lambda_i - \mu_i$ is positive. The lexicographic ordering is a total ordering, meaning that all partitions of a fixed degree are comparable. For example, the partitions of degree 4 are ordered as

$$(4, 0, 0, 0), (3, 1, 0, 0), (2, 2, 0, 0), (2, 1, 1, 0), (1, 1, 1, 1).$$

The second ordering we define on partitions is the dominance order $>$. The dominance ordering compares partitions of the same degree and is defined by

$$\lambda \geq \mu \iff \sum_{i=1}^k \lambda_i \geq \sum_{i=1}^k \mu_i, \forall k.$$

The dominance order is just a partial order, in fact the first incomparable partitions have degree 6: $(4, 1, 1)$ and $(3, 3, 0)$. However, generalizing this order, we can compare compositions of the same degree. First, we note that to each composition η corresponds a unique partition η^+ , which is obtained from η by reordering the elements of η in decreasing order:

$$\eta^+ = (\eta_1^+, \dots, \eta_N^+) \iff \eta_i^+ = \eta_{\sigma(i)} \text{ for some } \sigma \in S_N \text{ such that } \eta_1^+ \geq \dots \geq \eta_N^+.$$

The above comments allows to define the dominance order between compositions of the same degree, as follows:

$$\eta \succ \mu \iff \eta^+ > \mu^+ \text{ or } \eta^+ = \mu^+ \text{ and } \sum_{i=1}^k \eta_i \geq \sum_{i=1}^k \mu_i \quad \forall k,$$

where it is also assumed that $\eta \neq \mu$.

The following result will be used later in the proof of some propositions and lemmas and it was first stated without proof in Stanley's article [62] for α a formal parameter.

Lemma 2.1.1. *For any partition λ , let*

$$b(\lambda) = \sum_{i=1}^{\ell} (i-1)\lambda_i \quad \text{and} \quad \varepsilon_{\lambda}(\alpha) = \alpha b(\lambda') - b(\lambda).$$

Suppose that α is generic. Then,

$$\lambda > \mu \implies \varepsilon_{\lambda}(\alpha) \neq \varepsilon_{\mu}(\alpha).$$

Proof. Let us first define the lowering operators as follows:

$$L_{i,j}(\dots, \lambda_i, \dots, \lambda_j, \dots) = \begin{cases} (\dots, \lambda_i - 1, \dots, \lambda_j + 1, \dots) & \text{if } i < j \text{ and } \lambda_i - \lambda_j > 1 \\ (\dots, \lambda_i, \dots, \lambda_j, \dots) & \text{otherwise.} \end{cases} \quad (2.1.2)$$

Note that in general, if λ is a partition, then $L_{i,j}\lambda$ is a composition. However, from [53, Result (1.16)], one easily deduces that

$$\mu < \lambda \iff \mu = L_{i_k, j_k} \circ \dots \circ L_{i_1, j_1} \lambda \quad (2.1.3)$$

for some sequence $((i_1, j_1), \dots, (i_k, j_k))$ such that $L_{i_{k'}, j_{k'}} \circ \dots \circ L_{i_1, j_1} \lambda$ is a partition for all $1 \leq k' \leq k$. Now, let us suppose that $\bar{\lambda} = L_{i, j} \lambda$ is a partition for some $i < j$. Then, $b(\bar{\lambda}) - b(\lambda) = j - i > 0$. This last result together with equation (2.1.3) prove the following:

$$\mu < \lambda \implies b(\mu) > b(\lambda).$$

Moreover, it is well known [53, Result (1.11)], $\lambda > \mu$ if and only if $\mu' > \lambda'$. Consequently,

$$\varepsilon_\lambda(\alpha) - \varepsilon_\mu(\alpha) = \alpha(b(\lambda') - b(\mu')) + b(\mu) - b(\lambda) = \alpha p + q,$$

where p and q are positive integers. Therefore, $\varepsilon_\lambda(\alpha) - \varepsilon_\mu(\alpha) = 0$ only if α is a negative rational, and the lemma follows. \square

Definition 2.1.2 (Superpartitions and diagrams). *The ordered set $\Lambda = (\Lambda_1, \dots, \Lambda_m; \Lambda_{m+1}, \dots, \Lambda_N)$ of integers is a superpartition Λ of bi-degree $(n|m)$ if it satisfies the following conditions:*

$$\Lambda_1 \geq \dots \geq \Lambda_m \geq 0 \quad \Lambda_{m+1} \geq \dots \geq \Lambda_N \geq 0 \quad \sum_{i=1}^N \Lambda_i = n.$$

If $(\Lambda_1, \dots, \Lambda_m)$ is moreover strictly decreasing, then Λ is called a strict superpartition. Equivalently, we can write the superpartition Λ as a pair of partitions $(\Lambda^\circledast, \Lambda^)$ such that*

$$\Lambda^\circledast = (\Lambda_1 + 1, \dots, \Lambda_m + 1, \Lambda_{m+1}, \dots, \Lambda_N)^+, \quad \Lambda^* = (\Lambda_1, \dots, \Lambda_m, \Lambda_{m+1}, \dots, \Lambda_N)^+,$$

where $+$ indicates the operation that reorder the elements of a composition in decreasing order. The diagram of Λ is obtained from that of Λ^\circledast by replacing the boxes belonging to the skew diagram $\Lambda^\circledast/\Lambda^$ by circles.*

For instance, the ordered set $\Lambda = (4, 3, 0; 4)$ is a strict superpartitions of bi-degree $(11|3)$. It can be written as a pair $(\Lambda^\circledast, \Lambda^)$, where $\Lambda^\circledast = (4 + 1, 3 + 1, 0 + 1, 4)^+ = (5, 4, 4, 1)$ and $\Lambda^* = (4, 4, 3, 0)$. The diagram associated to Λ is obtained*

as follows:

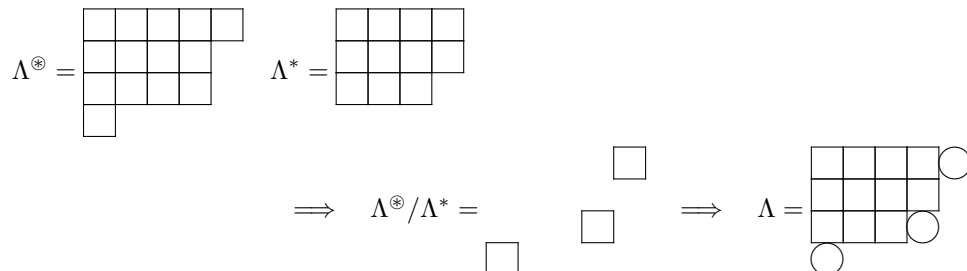

The dominance order for superpartitions is defined as follows

$$\Lambda > \Omega \iff \Lambda^* > \Omega^* \text{ or } \Lambda^* = \Omega^* \text{ and } \Lambda^\circledast > \Omega^\circledast.$$

For example, we consider $\Omega = (5, 3, 1; 2)$ and $\Gamma = (3, 1, 0; 5, 2)$ superpartitions of the same bi-degree. The associated diagrams are respectively

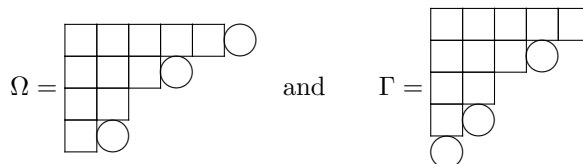

One easily verifies that $\Omega > \Gamma$, while Λ as above is comparable with neither Ω nor Γ .

As we will see in the present and the following chapters we will use properties of the non-symmetric Jack polynomials to prove properties and conjectures about the Jack polynomials with prescribed symmetry. To this end we introduce below a way to compare compositions and superpartitions.

Let $\gamma = (\gamma_1, \dots, \gamma_N)$ be a composition of n . Fix a positive integer $m \leq N$. We define now the map φ_m which associate to any composition γ a superpartition Γ as follows

$$\varphi_m(\gamma) = (\Gamma^*, \Gamma^\circledast), \quad \Gamma^* = (\gamma_1, \dots, \gamma_N)^+, \quad \Gamma^\circledast = (\gamma_1+1, \dots, \gamma_m+1, \gamma_{m+1}, \dots, \gamma_N)^+.$$

In other words, φ_m maps the composition γ to the superpartition $\Gamma = (\Gamma^*, \Gamma^\circledast)$ of bi-degree $(n|m)$, which as mentioned before, it is given by

$$\Gamma = ((\gamma_1, \dots, \gamma_m)^+; (\gamma_{m+1}, \dots, \gamma_N)^+).$$

Lemma 2.1.3. *Let $\Lambda = \varphi_m(\lambda)$ and $\Gamma = \varphi_m(\gamma)$, where λ and γ are compositions of the same degree. If $\lambda \succ \gamma$, then $\Lambda > \Gamma$.*

Proof. There are two possible cases.

- (1) Suppose that $\lambda^+ > \gamma^+$. Then, obviously, $\Lambda^* > \Gamma^*$.
- (2) Suppose that (i) $\lambda^+ = \gamma^+$ and (ii) $\sum_{i=1}^k \lambda_i \geq \sum_{i=1}^k \gamma_i, \forall k$. Equation (i) implies that $\Lambda^* = \Gamma^*$. Equation (ii) implies that γ is a permutation of λ that can be written as

$$\gamma = s_{i_l, j_l} \circ \cdots \circ s_{i_1, j_1} \lambda,$$

where each $s_{i,j}$ is a transposition such that

$$s_{i,j}(\dots \lambda_i, \dots, \lambda_j, \dots) = \begin{cases} (\dots \lambda_j, \dots, \lambda_i, \dots) & \text{if } i < j \text{ and } \lambda_i > \lambda_j \\ (\dots \lambda_i, \dots, \lambda_j, \dots) & \text{otherwise.} \end{cases} \quad (2.1.4)$$

Now, if $1 \leq i < j \leq m$ or $m+1 \leq i < j \leq N$, then $\varphi_m(s_{i,j}\lambda) = \Lambda$. This means that $s_{i,j}$ induces, via the map φ_m , a nontrivial action on the superpartition Λ only if $i \in I = \{1, \dots, m\}$ and $j \in J = \{m+1, \dots, N\}$. To be more explicit, let i' and j' be such that φ_m maps λ_i to $\Lambda_{i'}$ and λ_j to $\Lambda_{j'}$, respectively. Then,

$$\varphi_m(s_{i,j}\lambda) = \hat{s}_{i',j'} \varphi_m(\lambda) = \hat{s}_{i',j'} \Lambda,$$

where $\hat{s}_{i',j'} \Lambda$ is equal to

$$((\Lambda_1, \dots, \Lambda_{j'}, \dots, \Lambda_m)^+; (\Lambda_{m+1}, \dots, \Lambda_{i'}, \dots, \Lambda_N)^+)$$

whenever if $i' \in I, j' \in J$ and $\Lambda_{i'} > \Lambda_{j'}$, while $\hat{s}_{i',j'} \Lambda = \Lambda$ otherwise. Therefore, $\Lambda^* = \Gamma^*$ and

$$\Gamma = \varphi_m(\gamma) = \varphi_m(s_{i_l, j_l} \circ \cdots \circ s_{i_1, j_1} \lambda) = s_{i'_l, j'_l} \circ \cdots \circ s_{i'_1, j'_1} \Lambda,$$

which implies that $\Gamma^\otimes < \Lambda^\otimes$, as required.

□

Lemma 2.1.4. *For any superpartition Λ , let*

$$\epsilon_\Lambda = \sum_{s \in \Lambda^\otimes / \Lambda^*} (\alpha a'_{\Lambda^\otimes}(s) - l'_{\Lambda^\otimes}(s)).$$

Suppose that α is generic. Then,

$$\Lambda^* = \Omega^* \quad \text{and} \quad \Lambda^\otimes > \Omega^\otimes \quad \implies \quad \epsilon_\Lambda(\alpha) \neq \epsilon_\Omega(\alpha).$$

Proof. Let Ω be a superpartition be such that $\Omega^* = \Lambda^*$ and $\Omega^\otimes = L_{i,j}\Lambda^\otimes$ for some $i < j$, where $L_{i,j}$ is the lowering operator defined in equation (2.1.2). Note that this assumption makes sense only if $\Lambda_i^* > \Lambda_j^*$. Then, the diagram of Ω^\otimes differs from that of Λ^\otimes only in the rows i and j , so that

$$\sum_{s \in \Lambda^\otimes / \Lambda^*} a'_{\Lambda^\otimes}(s) - \sum_{s \in \Omega^\otimes / \Omega^*} a'_{\Omega^\otimes}(s) = \Lambda_i^* - \Lambda_j^* > 0,$$

and

$$\sum_{s \in \Lambda^\otimes / \Lambda^*} l'_{\Lambda^\otimes}(s) - \sum_{s \in \Omega^\otimes / \Omega^*} l'_{\Omega^\otimes}(s) = i - j < 0.$$

Finally, recalling equation (2.1.3), we find that

$$\epsilon_\Lambda(\alpha) - \epsilon_\Omega(\alpha) = \alpha p + q, \quad \text{where} \quad p, q \in \mathbb{Z}_+.$$

Clearly, if α is not a negative rational, then $\epsilon_\Lambda(\alpha) - \epsilon_\Omega(\alpha) \neq 0$, as required. \square

2.2 SYMMETRIC POLYNOMIALS

In this section we consider the polynomial ring $\mathbb{Q}[x_1, \dots, x_N]$ over \mathbb{Q} in the variables x_1, \dots, x_N with the natural action of the symmetric group S_N over polynomials, given by

$$K_{i,j}f(x_1, \dots, x_i, \dots, x_j, \dots, x_N) = f(x_1, \dots, x_j, \dots, x_i, \dots, x_N) \quad (2.2.1)$$

for $f(x_1, \dots, x_i, \dots, x_j, \dots, x_N) \in \mathbb{Q}[x_1, \dots, x_N]$ and $K_{i,j} \in S_N$ the permutation that exchanges i and j . In particular we will use the shorthand notation for transpositions: $K_i = K_{i,i+1}$.

A polynomial is called symmetric if it is invariant under the action of any permutation, i.e.

$$K_i f(x) = f(x) \quad \text{for all} \quad i = 1, \dots, N-1.$$

It is well known that any symmetric polynomial can be expressed as a linear combination of the elementary symmetric functions, which are denoted by $e_\lambda := e_{\lambda_1} \dots e_{\lambda_N}$ for $\lambda = (\lambda_1, \dots, \lambda_N)$ a partition, and where

$$e_r(x) = \sum_{1 \leq i_1 < \dots < i_r \leq N} x_{i_1} \dots x_{i_r}.$$

Another important basis consists in the monomial symmetric functions, denoted by m_λ , where for a given partition $\lambda = (\lambda_1, \dots, \lambda_N)$,

$$m_\lambda(x) = x_1^{\lambda_1} \dots x_N^{\lambda_N} + \text{distinct permutations}.$$

Other classes of symmetric polynomials associated to the partition $\lambda = (\lambda_1, \dots, \lambda_N)$ are the complete symmetric function

$$h_\lambda(x) = h_{\lambda_1} \dots h_{\lambda_N},$$

where

$$h_r(x) = \sum_{1 \leq i_1 \leq \dots \leq i_r \leq N} x_{i_1} \dots x_{i_r},$$

as well as the power sum

$$p_\lambda(x) := p_{\lambda_1} \dots p_{\lambda_N},$$

where

$$p_r(x) = \sum_{i=1}^N x_i^r.$$

Example 2.2.1. For the partition $\lambda = (3, 1, 0)$ with the number of variables $N = 3$ fixed, we show below the corresponding element in each of the basis mentioned above:

$$\begin{aligned} e_{(3,1,0)}(x_1, x_2, x_3) &= e_3(x_1, x_2, x_3) \cdot e_1(x_1, x_2, x_3) \cdot e_0(x_1, x_2, x_3) \\ &= x_1 x_2 x_3 \cdot (x_1 + x_2 + x_3) \cdot 1 \\ &= x_1^2 x_2 x_3 + x_1 x_2^2 x_3 + x_1 x_2 x_3^2 \end{aligned}$$

while

$$m_{(3,1,0)}(x_1, x_2, x_3) = x_1^3 x_2 + x_1 x_2^3 + x_1^3 x_3 + x_1 x_3^3 + x_2^3 x_3 + x_2 x_3^3$$

and

$$\begin{aligned} h_{(3,1,0)}(x_1, x_2, x_3) &= h_3(x_1, x_2, x_3) \cdot h_1(x_1, x_2, x_3) \cdot h_0(x_1, x_2, x_3) \\ &= (x_1^3 + x_2^3 + x_3^3 + x_1^2 x_2 + x_1 x_2^2 + x_1^2 x_3 + x_1 x_3^2 + x_2^2 x_3 + x_2 x_3^2 + x_1 x_2 x_3) \cdot (x_1 + x_2 + x_3) \cdot 1 \\ &= (x_1^3 + x_2^3 + x_3^3 + x_1^2 x_2 + x_1 x_2^2 + x_1^2 x_3 + x_1 x_3^2 + x_2^2 x_3 + x_2 x_3^2 + x_1 x_2 x_3) \cdot (x_1 + x_2 + x_3) \end{aligned}$$

and

$$\begin{aligned} p_{(3,1,0)}(x_1, x_2, x_3) &= p_3(x_1, x_2, x_3) \cdot p_1(x_1, x_2, x_3) \cdot p_0(x_1, x_2, x_3) \\ &= (x_1^3 + x_2^3 + x_3^3) \cdot (x_1 + x_2 + x_3) \cdot 1 \\ &= x_1^4 + x_1^3 x_2 + x_1^3 x_3 + x_1 x_2^3 + x_2^4 + x_2^3 x_3 + x_1 x_3^3 + x_2 x_3^3 + x_3^4. \end{aligned}$$

One special type of symmetric polynomials are the symmetric Jack polynomials. They can be defined in various ways: by using combinatorial formulas in terms of certain generalized tableaux (see [47]), by symmetrizing the non-symmetric Jack polynomials or as an orthogonal family of functions which is compatible with the canonical filtration of the ring of symmetric functions. However, as we have mentioned in the introduction, the most natural way for us is to characterize them as triangular eigenfunctions of the differential operator D given by (1.1.3). They are uniquely determined by the properties of being monic and triangular in the monomial basis, where the triangularity is taken with respect to the dominance ordering. Thus P_λ is the unique element of $\mathcal{S}_{\{1, \dots, N\}}$ that satisfies the following two properties:

$$(A1) \quad P_\lambda = m_\lambda + \sum_{\mu < \lambda} c_{\lambda, \mu}(\alpha) m_\mu,$$

$$(A2) \quad DP_\lambda = \varepsilon_\lambda(\alpha) P_\lambda,$$

where $\varepsilon_\lambda(\alpha)$ is the eigenvalue given in Lemma 2.1.1.

For instance,

$$P_{(2)} = m_{(2)} + \frac{2}{\alpha + 1} m_{(1,1)}$$

and if $N = 3$, then

$$P_{(2)}(x_1, x_2, x_3; \alpha) = x_1^2 + x_2^2 + x_3^2 + \frac{2}{\alpha + 1} (x_1 x_2 + x_1 x_3 + x_2 x_3)$$

and

$$P_{(3)} = m_{(3)} + \frac{3}{2\alpha + 1} m_{(2,1)} + \frac{6}{(2\alpha + 1)(\alpha + 1)} m_{(1,1,1)}$$

and if $N = 3$, then

$$\begin{aligned} P_{(3)}(x_1, x_2, x_3; \alpha) &= x_1^3 + x_2^3 + x_3^3 + \frac{6}{(2\alpha + 1)(\alpha + 1)} x_1 x_2 x_3 \\ &\quad + \frac{3}{2\alpha + 1} (x_1^2 x_2 + x_1 x_2^2 + x_1^2 x_3 + x_1 x_3^2 + x_2^2 x_3 + x_2 x_3^2). \end{aligned}$$

Remark 2.2.2. *More examples of symmetric Jack polynomials will be given in the first part of the table in Appendix B.*

2.3 NON-SYMMETRIC JACK POLYNOMIALS

We introduce the counterpart of the symmetric Jack polynomials, the non-symmetric Jack polynomials. After their definition, we recall their stability property, which will be used in the next section to prove the stability property of the Jack polynomials with prescribed symmetry. At the end of this section we prove that the non-symmetric Jack polynomials are eigenfunctions of the Sekiguchi operators.

As we have mentioned earlier, there are many ways to define the non-symmetric Jack polynomials [58] (see also [47]). However, the most natural way for us is to characterize them as triangular eigenfunctions of commuting difference-differential operators, first introduced in physics in [12], and later generalized to general root systems by Cherednik. We define these operators as follows:

$$\xi_j = \alpha x_j \partial_{x_j} + \sum_{i < j} \frac{x_j}{x_j - x_i} (1 - K_{ij}) + \sum_{i > j} \frac{x_i}{x_j - x_i} (1 - K_{ij}) - (j - 1), \quad (2.3.1)$$

where the operators $K_{i,j}$ were given in (2.2.1).

Let η be a composition and let α be formal parameter or a non-zero complex number not equal to a negative rational. Then, the non-symmetric Jack polynomial $E_\eta(x; \alpha)$ is the unique polynomial satisfying

$$(A1') \quad E_\eta(x; \alpha) = x^\eta + \sum_{\nu < \eta} c_{\eta, \nu} x^\nu, \quad c_{\eta, \nu} \in \mathbb{C}(\alpha),$$

$$(A2') \quad \xi_j E_\eta = \bar{\eta}_j E_\eta \quad \forall j = 1, \dots, N,$$

where the eigenvalues are given by

$$\bar{\eta}_j = \alpha\eta_j - \#\{i < j | \eta_i \geq \eta_j\} - \#\{i > j | \eta_i > \eta_j\}. \quad (2.3.2)$$

One important property of the non-symmetric Jack polynomials is their stability with respect to the number of variables (see [47, Corollary 3.3]). To be more precise, let $\eta = (\eta_1, \dots, \eta_N)$ and $\eta_- = (\eta_1, \dots, \eta_{N-1})$ be compositions. Then,

$$E_\eta(x_1, \dots, x_N)|_{x_N=0} = \begin{cases} 0 & \text{if } \eta_N > 0, \\ E_{\eta_-}(x_1, \dots, x_{N-1}) & \text{if } \eta_N = 0. \end{cases} \quad (2.3.3)$$

Remark 2.3.1. *The recursion formula for non-symmetric Jack polynomials will be given in Appendix A.*

We now prove a closely related property that will help us to establish the stability of the Jack polynomials with prescribed symmetry.

Lemma 2.3.2. *Let $\lambda = (\lambda_1, \dots, \lambda_m)$ and $\mu = (\mu_{m+1}, \dots, \mu_{N-1})$ be partitions. Let also*

$$\eta = (\lambda_m, \dots, \lambda_1, 0, \mu_{N-1}, \dots, \mu_{m+1}) \quad \text{and} \quad \eta_- = (\lambda_m, \dots, \lambda_1, \mu_{N-1}, \dots, \mu_{m+1}).$$

Finally assume that $\mu_{m+1} > 0$. Then,

$$E_\eta(x_1, \dots, x_m, x_N, x_{m+1}, \dots, x_{N-1})|_{x_N=0} = E_{\eta_-}(x_1, \dots, x_m, x_{m+1}, \dots, x_{N-1}).$$

Proof. We first remark that

$$\begin{aligned} E_\eta(x_1, \dots, x_m, x_N, x_{m+1}, \dots, x_{N-1}) \\ = K_{N-1} \dots K_{m+1} E_\eta(x_1, \dots, x_m, x_{m+1}, \dots, x_{N-1}, x_N). \end{aligned}$$

Now, the action of the symmetric group on the non-symmetric Jack polynomials is (see [4, Eq. (2.21)])

$$K_i E_\eta = \begin{cases} \frac{1}{\delta_{i,\eta}} E_\eta + (1 - \frac{1}{\delta_{i,\eta}^2}) E_{K_i(\eta)}, & \eta_i > \eta_{i+1} \\ E_\eta, & \eta_i = \eta_{i+1} \\ \frac{1}{\delta_{i,\eta}} E_\eta + E_{K_i(\eta)}, & \eta_i < \eta_{i+1} \end{cases} \quad (2.3.4)$$

where $\delta_{i,\eta} = \bar{\eta}_i - \bar{\eta}_{i+1}$. In our case, given that we are using a composition in increasing order, we can use successively the third line of (2.3.4) and we get

$$E_\eta(x_1, \dots, x_m, x_N, x_{m+1}, \dots, x_{N-1}) = E_{K_{N-1} \dots K_{m+1}(\eta)}(x_1, \dots, x_N) + \sum_{\gamma} c_{\lambda, \gamma} E_\gamma(x_1, \dots, x_N).$$

In the last equation, the sum is taken over the compositions γ of the form

$$\gamma = (\lambda_m, \dots, \lambda_1, \omega(0, \mu_{N-1}, \dots, \mu_{m+1})),$$

where ω is a permutation of the composition formed by a strict subsequence of the transpositions K_{N-1}, \dots, K_{m+1} and the coefficients $c_{\lambda, \gamma}$ are obtained as products of $1/\delta_{i,j}$. The important point here is that for any such γ , we have $\gamma_N \neq 0$. Moreover,

$$K_{N-1} \dots K_{m+1}(\eta) = (\lambda_m, \dots, \lambda_1, \mu_{N-1}, \dots, \mu_{m+1}, 0).$$

Then, applying the stability property (2.3.3), we find $E_\gamma(x_1, \dots, x_N)|_{x_N=0} = 0$ and $E_{K_{N-1} \dots K_{m+1}(\eta)}(x_1, \dots, x_N)|_{x_N=0} = E_{\eta^-}(x_1, \dots, x_{N-1})$, which completes the proof. \square

Lemma 2.3.3. *Let $\gamma = (\gamma_1, \dots, \gamma_N)$ be a composition and let us fix a positive integer m with $m \leq N$. Then, $E_\gamma(x; \alpha)$ is an eigenfunction of the operators $S^*(u)$ and $S^\otimes(u, v)$ defined in (1.5.1). Moreover, let $\Gamma = \varphi_m(\gamma)$ be the associated superpartition to γ . Then,*

$$S^*(u) E_\gamma = \varepsilon_{\Gamma^*}(\alpha, u) E_\gamma \quad S^\otimes(u, v) E_\gamma = \varepsilon_{\Gamma^\otimes}(\alpha, u) E_\gamma,$$

where the eigenvalue $\varepsilon_\lambda(\alpha, u)$ is defined in (1.5.2).

Proof. The fact that the non-symmetric Jack polynomials are eigenfunctions of the Sekiguchi operators immediately follows from $\xi_i E_\gamma = \bar{\gamma}_i E_\gamma$. Explicitly,

$$S^*(u) E_\gamma = \prod_{i=1}^N (u + \bar{\gamma}_i) E_\gamma, \quad S^\otimes(u, v) E_\gamma = \prod_{i=1}^m (u + \bar{\gamma}_i + \alpha) \prod_{i=m+1}^N (v + \bar{\gamma}_i) E_\gamma.$$

In order to express the eigenvalues in terms of partitions rather than compositions, we need to consider permutations on words with N symbols. Amongst all

the permutations w such that $\gamma = w(\gamma^+)$, there exists a unique one, denoted by w_γ , of minimal length. Equivalently, w_γ is the smallest element of S_N satisfying

$$\gamma_{w_\gamma(i)} = \gamma_i^+ \quad \text{for each } i = 1, \dots, N. \quad (2.3.5)$$

Now, let $\delta^- = (0, 1, \dots, N-1)$. As is well known, the eigenvalue $\bar{\gamma}_i$ is equal to the i th element of the composition $(\alpha\gamma - w_\gamma\delta^-)$, which means that

$$\bar{\gamma}_i = \alpha\gamma_{w_\gamma^{-1}(i)}^+ - \delta_{w_\gamma^{-1}(i)}^-$$

or equivalently

$$\bar{\gamma}_{w(i)} = \alpha\gamma_i^+ - (i-1).$$

In our case, $\gamma^+ = \Gamma^*$, so that

$$\prod_{i=1}^N (u + \bar{\gamma}_i) = \prod_{i=1}^N (u + \alpha\Gamma_i^* - i + 1),$$

which is the first expected eigenvalue. For the second Sekiguchi operator, we note that the shifted composition $(\gamma_1 + 1, \dots, \gamma_m + 1, \gamma_{m+1}, \dots, \gamma_N)$ is equal to $w_\gamma(\Gamma^\otimes)$. Consequently,

$$\prod_{i=1}^m (u + \bar{\gamma}_i + \alpha) \prod_{i=m+1}^N (u + \bar{\gamma}_i) = \prod_{i=1}^N (u + \alpha\Gamma_i^\otimes - i + 1),$$

and the lemma follows. \square

2.4 JACK POLYNOMIALS WITH PRESCRIBED SYMMETRY

All along this section we introduce different types of polynomials with prescribed symmetry (monomial polynomials and Jack polynomials). Also for generic α we prove the regularity and triangularity properties independent the type of symmetry of the Jack polynomials. Moreover, we show the stability property for each family of Jack polynomials with prescribed symmetry and we give a characterization of the Jack polynomials with prescribed symmetry as eigenfunctions of the Sekiguchi operators (Theorem 2.4.10).

For any subset K of $\{1, \dots, N\}$, let S_K denote the subgroup of the permutation group of $\{1, \dots, N\}$ that leaves the complement of K invariant. The anti-

symmetrization and symmetrization operators for K are defined as follows:

$$\text{Asym}_K f(x) = \sum_{\sigma \in \mathcal{S}_K} (-1)^\sigma f(x_{\sigma(1)}, \dots, x_{\sigma(N)}) \quad \text{and} \quad (2.4.1)$$

$$\text{Sym}_K f(x) = \sum_{\sigma \in \mathcal{S}_K} f(x_{\sigma(1)}, \dots, x_{\sigma(N)}). \quad (2.4.2)$$

for any pair (i, j) of elements of K , we have

$$K_{i,j} \text{Asym}_K f(x) = -\text{Asym}_K f(x) \quad \text{and} \quad K_{i,j} \text{Sym}_K f(x) = \text{Sym}_K f(x).$$

Notice that in the following paragraphs, the set K will be either $I = \{1, \dots, m\}$ or $J = \{m+1, \dots, N\}$.

The vector space $\mathcal{A}_I \otimes \mathcal{S}_J|_n$ consists of all polynomials of total degree n that are antisymmetric with respect to the set of variables $\{x_1, \dots, x_m\}$, and symmetric with respect to $\{x_{m+1}, \dots, x_N\}$. This space is spanned by all polynomials of the form $\text{Asym}_I \text{Sym}_J x^\eta$, where η runs over all compositions of n . However, by considering the symmetry of the polynomials, we see that $\mathcal{A}_I \otimes \mathcal{S}_J|_n$ is also spanned by the following set of linearly independent polynomials:

$$\{m_\Lambda^{\text{AS}} \mid \Lambda \text{ is a strict superpartition of bi-degree } (n|m)\},$$

where the monomial m_Λ^{AS} is defined as

$$m_\Lambda^{\text{AS}}(x) = a_\lambda(x_1, \dots, x_m) m_\mu(x_{m+1}, \dots, x_N),$$

$$\lambda = (\Lambda_1, \dots, \Lambda_m), \quad \mu = (\Lambda_{m+1}, \dots, \Lambda_N).$$

We recall that in the last equation, a_λ and m_μ denote the antisymmetric and symmetric monomial functions respectively.

Similarly, the following sets provide bases for the vector spaces $\mathcal{A}_I \otimes \mathcal{A}_J|_n$, $\mathcal{S}_I \otimes \mathcal{A}_J|_n$, $\mathcal{S}_I \otimes \mathcal{S}_J|_n$,

$$\{m_\Lambda^{\text{AA}} \mid \Lambda \text{ is a strict superpartition of bi-degree } (n|m) \text{ such that } \Lambda_{m+1} > \dots > \Lambda_N\}, \quad (2.4.3)$$

$$\{m_\Lambda^{\text{SA}} \mid \Lambda \text{ is a superpartition of bi-degree } (n|m) \text{ such that } \Lambda_{m+1} > \dots > \Lambda_N\}, \quad (2.4.4)$$

$$\{m_\Lambda^{\text{SS}} \mid \Lambda \text{ is a superpartition of bi-degree } (n|m)\}, \quad (2.4.5)$$

where

$$m_{\Lambda}^{\text{AA}}(x) = a_{\lambda}(x_1, \dots, x_m) a_{\mu}(x_{m+1}, \dots, x_N), \quad (2.4.6)$$

$$m_{\Lambda}^{\text{SA}}(x) = m_{\lambda}(x_1, \dots, x_m) a_{\mu}(x_{m+1}, \dots, x_N), \quad (2.4.7)$$

$$m_{\Lambda}^{\text{SS}}(x) = m_{\lambda}(x_1, \dots, x_m) m_{\mu}(x_{m+1}, \dots, x_N). \quad (2.4.8)$$

$$(2.4.9)$$

Example 2.4.1. *Monomials polynomials with prescribed symmetry.*

λ	a_{λ}	μ	m_{μ}	m_{Λ}^{AS}
(1, 0)	$x_1 - x_2$	(1, 1)	$x_3 x_4$	$(x_1 - x_2) x_3 x_4$
(1, 0)	$x_1 - x_2$	(2, 1)	$x_3^2 x_4 + x_3 x_4^2$	$(x_1 - x_2)(x_3^2 x_4 + x_3 x_4^2)$
(2, 0)	$x_1^2 - x_2^2$	(2, 0)	$x_3^2 + x_4^2$	$(x_1^2 - x_2^2)(x_3^2 + x_4^2)$
λ	a_{λ}	μ	a_{μ}	m_{Λ}^{AA}
(1, 0)	$x_1 - x_2$	(1, 1)	0	0
(1, 0)	$x_1 - x_2$	(2, 1)	$x_3^2 x_4 - x_3 x_4^2$	$(x_1 - x_2)(x_3^2 x_4 - x_3 x_4^2)$
(2, 0)	$x_1^2 - x_2^2$	(2, 0)	$x_3^2 - x_4^2$	$(x_1^2 - x_2^2)(x_3^2 - x_4^2)$
λ	m_{λ}	μ	a_{μ}	m_{Λ}^{SA}
(1, 0)	$x_1 + x_2$	(1, 1)	0	0
(1, 0)	$x_1 + x_2$	(2, 1)	$x_3^2 x_4 - x_3 x_4^2$	$(x_1 + x_2)(x_3^2 x_4 - x_3 x_4^2)$
(2, 0)	$x_1^2 + x_2^2$	(2, 0)	$x_3^2 - x_4^2$	$(x_1^2 + x_2^2)(x_3^2 - x_4^2)$
λ	m_{λ}	μ	m_{μ}	m_{Λ}^{SS}
(1, 0)	$x_1 + x_2$	(1, 1)	$x_3 x_4$	$(x_1 + x_2) x_3 x_4$
(1, 0)	$x_1 + x_2$	(2, 1)	$x_3^2 x_4 + x_3 x_4^2$	$(x_1 + x_2)(x_3^2 x_4 + x_3 x_4^2)$
(2, 0)	$x_1^2 + x_2^2$	(2, 0)	$x_3^2 + x_4^2$	$(x_1^2 + x_2^2)(x_3^2 + x_4^2)$

We recall that the Jack polynomials with prescribed symmetry AS, AA, SA, SS have been introduced in Definition 1.3. They are indexed by a superpartition $\Lambda = (\Lambda_1, \dots, \Lambda_m; \Lambda_{m+1}, \dots, \Lambda_N)$ and are defined as follows:

$$P_{\Lambda}(x; \alpha) = c_{\Lambda} \mathcal{O}_{I, J} E_{\eta}, \quad (2.4.10)$$

where $\mathcal{O}_{I,J}$ stands for the appropriate composition of antisymmetrization and/or symmetrization operators, and

$$\eta = (\Lambda_m, \dots, \Lambda_1, \Lambda_N, \dots, \Lambda_{m+1}). \quad (2.4.11)$$

Moreover, the coefficient c_Λ is chosen such that the polynomial P_Λ is monic, i.e., the coefficient of m_Λ in P_Λ is exactly one. Since, our definition is such that only the non-symmetric monomial $\mathcal{O}_{I,J}x^\eta$ contributes to the coefficient of m_Λ , it is an easy exercise to extract the normalization coefficient:

$$c_\Lambda^{\text{AS}} = \frac{(-1)^{m(m-1)/2}}{f_\mu}, \quad (2.4.12)$$

$$c_\Lambda^{\text{AA}} = (-1)^{m(m-1)/2} (-1)^{(N-m)(N-m-1)/2}, \quad (2.4.13)$$

$$c_\Lambda^{\text{SA}} = \frac{(-1)^{(N-m)(N-m-1)/2}}{f_\lambda}, \quad (2.4.14)$$

$$c_\Lambda^{\text{SS}} = \frac{1}{f_\lambda f_\mu}, \quad (2.4.15)$$

where $\lambda = (\Lambda_1, \dots, \Lambda_m)$, $\mu = (\Lambda_{m+1}, \dots, \Lambda_N)$, $f_\lambda = \prod_i n_\lambda(i)!$ and $n_\lambda(i)$ is the multiplicity of i in λ .

As an example, the following polynomial

$$P_{(1;2,0,0)}^{\text{AS}} = m_{(1;2,0,0)}^{\text{AS}} + \frac{1}{\alpha+1} m_{(0;2,1,0)}^{\text{AS}} + \frac{2}{\alpha+1} m_{(1;1,1,0)}^{\text{AS}} + \frac{6}{(\alpha+2)(\alpha+1)} m_{(0;1,1,1)}^{\text{AS}}$$

shows us the triangular structure of the Jack polynomials with prescribed symmetry with respect to prescribed monomials, and the existence of singularities for some negative values of α . These properties, that immediately follow from their Definition (2.4.10), will be proved in general for Jack polynomials with prescribed symmetry independently of the type of symmetry.

Remark 2.4.2. *More examples of Jack polynomials will be given in Appendix B.*

Lemma 2.4.3 (Regularity for generic α). *$P_\Lambda(x; \alpha)$ is singular only if α is zero or a negative rational.*

Proof. All the dependence upon α comes from the non-symmetric Jack polynomials, so it is sufficient to consider the possible singularities of the latter. Let us now recall a fundamental result of Knop and Sahi [47]: There is a $v_\eta(\alpha) \in \mathbb{N}[\alpha]$ such that all the coefficients in $v_\eta(\alpha)E_\eta(x; \alpha)$ belong to $\mathbb{N}[\alpha]$. Thus, the only singularities of $E_\eta(x; \alpha)$ are poles, which can occur only at $\alpha = 0$ or for some $\alpha \in \mathbb{Q}_-$. \square

Lemma 2.4.4 (Simple product). *For any superpartition*

$$\Lambda = (\Lambda_1, \dots, \Lambda_m; \Lambda_{m+1}, \dots, \Lambda_N),$$

let

$$\Lambda_+ = (\Lambda_1 + 1, \dots, \Lambda_m + 1; \Lambda_{m+1} + 1, \dots, \Lambda_N + 1).$$

Then,

$$x_1 \cdots x_N P_\Lambda(x; \alpha) = P_{\Lambda_+}(x; \alpha).$$

Proof. By using the known property of non-symmetric Jack polynomials, $x_1 \cdots x_N E_\eta(x; \alpha) = E_{(\eta_1+1, \dots, \eta_N+1)}(x; \alpha)$, the definition given in 2.4.10 and the fact that $x_1 \cdots x_N$ commutes with any $\mathcal{O}_{I,J}$, we conclude that

$$x_1 \cdots x_N P_\Lambda(x; \alpha) = c_\Lambda \mathcal{O}_{I,J} E_{(\eta_1+1, \dots, \eta_N+1)}(x; \alpha) = \frac{c_\Lambda}{c_{\Lambda_+}} P_{\Lambda_+}(x; \alpha).$$

Finally, one easily verifies from equations (2.4.12)–(2.4.15), that $c_\Lambda = c_{\Lambda_+}$. \square

Proposition 2.4.5 (Triangularity). $P_\Lambda = m_\Lambda + \sum_{\Gamma < \Lambda} c_{\Lambda, \Gamma} m_\Gamma$.

Proof. By definition, $P_\Lambda = c_\Lambda \mathcal{O}_{I,J} E_\eta$, where η is given by (2.4.11) and $E_\eta = x^\eta + \sum_{\nu \prec \eta} c_{\eta, \nu} x^\nu$. We already know that c_Λ guarantees the monocity, i.e., $c_\Lambda \mathcal{O}_{I,J} x^\eta = m_\Lambda$. It remains to check that if $\nu \prec \eta$, then $\mathcal{O}_{I,J} x^\nu$ is proportional to m_Ω for some $\Omega < \Lambda$. Now, $\mathcal{O}_{I,J} x^\nu$ is proportional to m_Ω , where $\Omega = \varphi_m(\nu)$. Moreover, we know from Lemma 2.1.3 that $\nu \prec \eta$, then $\varphi_m(\nu) < \varphi_m(\lambda)$. This completes the proof. \square

Proposition 2.4.6 (Stability for types AS and SS). *Let*

$\Lambda = (\Lambda_1, \dots, \Lambda_m; \Lambda_{m+1}, \dots, \Lambda_N)$ *be a superpartition and let*

$\Lambda_- = (\Lambda_1, \dots, \Lambda_m; \Lambda_{m+1}, \dots, \Lambda_{N-1})$. *Then, the Jack polynomial with prescribed symmetry AS or SS satisfies*

$$P_\Lambda(x_1, \dots, x_N; \alpha)|_{x_N=0} = \begin{cases} 0, & \Lambda_N > 0, \\ P_{\Lambda_-}(x_1, \dots, x_{N-1}; \alpha), & \Lambda_N = 0. \end{cases}$$

Proof. The cases AS and SS being similar, we only give the proof for AS.

Let $\lambda = (\Lambda_1, \dots, \Lambda_m)$, $\mu = (\Lambda_{m+1}, \dots, \Lambda_N)$, $\lambda^- = (\Lambda_m, \dots, \Lambda_1)$, $\mu^- = (\Lambda_N, \dots, \Lambda_{m+1})$. Let also $\eta = (\lambda^-, \mu^-)$ and $\eta_- = (\lambda^-, \mu_-^-)$, where $\mu_-^- = (\Lambda_{N-1}, \dots, \Lambda_{m+1})$. By definition,

$$P_\Lambda^{AS}(x) = \frac{(-1)^{m(m-1)/2}}{f_\mu} \text{Asym}_I \text{Sym}_J E_\eta(x; \alpha).$$

The symmetrization operator can be decomposed as

$$\text{Sym}_J = \text{Sym}_{J_-} (1 + K_{m+1,N} + K_{m+2,N} + \dots + K_{N-1,N}), \quad J_- = \{m+1, \dots, N-1\}.$$

It is more convenient to rewrite the transpositions on the LHS in terms of the elementary transpositions:

$$K_{i,N} = K_i K_{i+1} \dots K_{N-2} K_{N-1} K_{N-2} \dots K_{i+1} K_i$$

By making use of the stability property (2.3.3) and the action of the symmetric group on the non-symmetric Jack polynomials given in (2.3.4), we then find that

$$K_{N-1} K_{N-2} \dots K_{i+1} K_i E_\eta|_{x_N=0} = \begin{cases} 0, & \eta_i > 0, \\ E_{\eta_-}(x_1, \dots, x_{N-1}), & \eta_i = 0. \end{cases}$$

Thus, $\text{Sym}_J E_\eta(x_1, \dots, x_N)|_{x_N=0} = 0$ when $\Lambda_N > 0$, while

$$\begin{aligned} & \text{Sym}_J E_\eta(x_1, \dots, x_N)|_{x_N=0} \\ &= \text{Sym}_{J_-} \left(\sum_{\substack{i \in \{m+1, \dots, N-1\} \\ \mu_i^- = 0}} K_i K_{i+1} \dots K_{N-2} \right) E_{\eta_-}(x_1, \dots, x_{N-1}) \\ &= n_\mu(0) \text{Sym}_{J_-} E_{\eta_-}(x_1, \dots, x_{N-1}) \end{aligned}$$

when $\Lambda_N = 0$, and the proposition follows. \square

Proposition 2.4.7 (Stability for types SA and SS). *Let*

$\Lambda = (\Lambda_1, \dots, \Lambda_m; \Lambda_{m+1}, \dots, \Lambda_N)$ *be a superpartition and let*

$\Lambda_- = (\Lambda_1, \dots, \Lambda_{m-1}; \Lambda_{m+1}, \dots, \Lambda_N)$. *Then, the Jack polynomial with prescribed symmetry SA or SS satisfies*

$$P_\Lambda(x_1, \dots, x_m, \dots, x_N; \alpha)|_{x_m=0} = \begin{cases} 0, & \Lambda_m > 0, \\ P_{\Lambda_-}(x_1, \dots, x_{m-1}, x_{m+1}, \dots, x_N; \alpha), & \Lambda_m = 0. \end{cases}$$

Proof. The cases SA and SS are almost identical, so we only prove the first. Below, we essentially follow the method used for proving Proposition 2.4.6, except that we use Lemma 2.3.2 rather than equation (2.3.3).

Let $\lambda = (\Lambda_1, \dots, \Lambda_m)$, $\mu = (\Lambda_{m+1}, \dots, \Lambda_N)$, $\lambda^- = (\Lambda_m, \dots, \Lambda_1)$, $\mu^- = (\Lambda_N, \dots, \Lambda_{m+1})$. Let also $\eta = (\lambda^-, \mu^-)$ and $\eta_- = (\lambda^-, \mu_-^-)$, where $\mu_-^- = (\Lambda_{N-1}, \dots, \Lambda_{m+1})$. By definition,

$$P_\Lambda^{SA}(x) = \frac{(-1)^{(N-m)(N-m-1)/2}}{f_\lambda} \text{Sym}_I \text{Asym}_J E_\eta(x; \alpha)$$

Notice that Sym_I and Asym_J commute. The symmetrization operator can be decomposed as

$$\text{Sym}_I = \text{Sym}_{I_-} (1 + K_{1,m} + K_{2,m} + \dots + K_{m-1,m}),$$

where $I_- = \{1, \dots, m-1\}$ and

$$K_{i,m} = K_i K_{i+1} \dots K_{m-2} K_{m-1} K_{m-2} \dots K_{i+1} K_i$$

Now, recalling (2.3.4) and the second stability property for the non-symmetric Jack polynomials, given in Lemma 2.3.2, we conclude that

$$K_{m-1} K_{m-2} \dots K_{i+1} K_i E_\eta|_{x_m=0} = \begin{cases} 0, & \eta_i > 0, \\ E_{\eta_-}(x_1, \dots, x_{N-1}), & \eta_i = 0. \end{cases}$$

Thus, $\text{Sym}_I E_\eta(x_1, \dots, x_N)|_{x_m=0} = 0$ when $\Lambda_m > 0$, while

$$\begin{aligned} & \text{Sym}_I E_\eta(x_1, \dots, x_N)|_{x_m=0} \\ &= \text{Sym}_{I_-} \left(\sum_{\substack{i \in \{1, \dots, m-1\} \\ \lambda_i^- = 0}} K_i K_{i+1} \dots K_{m-2} \right) E_{\eta_-}(x_1, \dots, x_{m-1}, x_{m+1}, \dots, x_N) \\ &= n_\lambda(0) \text{Sym}_{I_-} E_{\eta_-}(x_1, \dots, x_{m-1}, x_{m+1}, \dots, x_N), \end{aligned}$$

when $\Lambda_m = 0$, and the proposition follows. \square

The next proposition relates Jack polynomials with prescribed symmetry of different bi-degrees. It uses two basic operations on superpartitions. The first one is the removal of a column:

$$\mathcal{C}(\Lambda_1, \dots, \Lambda_m; \Lambda_{m+1}, \dots, \Lambda_N) = (\Lambda_1 - 1, \dots, \Lambda_m - 1; \Lambda_{m+1} - 1, \dots, \Lambda_N - 1) \\ \text{if } \Lambda_i > 0 \quad \forall 1 \leq i \leq N.$$

The second one is the removal of a circle:

$$\tilde{\mathcal{C}}(\Lambda_1, \dots, \Lambda_m; \Lambda_{m+1}, \dots, \Lambda_N) = (\Lambda_1, \dots, \Lambda_{m-1}; \Lambda_{m+1}, \dots, \Lambda_N) \quad \text{if } \Lambda_m = 0.$$

The operators \mathcal{C} and $\tilde{\mathcal{C}}$ are illustrated in Figure 2.1

Figure 2.1: Operators \mathcal{C} and $\tilde{\mathcal{C}}$

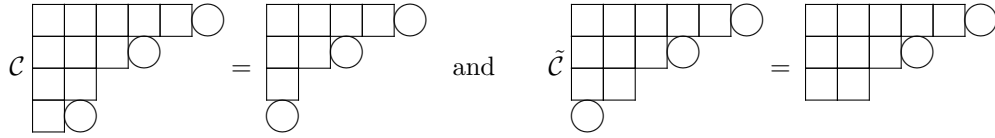

Proposition 2.4.8 (Removal of a column or a circle). *Let*

$$\Lambda = (\Lambda_1, \dots, \Lambda_m; \Lambda_{m+1}, \dots, \Lambda_N)$$

be a superpartition and let

$$P_\Lambda(x_1, \dots, x_m, \dots, x_N; \alpha)$$

be the associated Jack polynomial with prescribed symmetry AA, AS, SA, or SS.

If $\Lambda_i > 0$ for all $1 \leq i \leq N$, then

$$P_\Lambda(x_1, \dots, x_m, \dots, x_N; \alpha) = (x_1 \cdots x_N) P_{\mathcal{C}\Lambda}(x_1, \dots, x_m, \dots, x_N; \alpha).$$

If $\Lambda_m = 0$, then

$$P_\Lambda(x_1, \dots, x_m, \dots, x_N; \alpha) \Big|_{x_m=0} = \epsilon_m P_{\tilde{\mathcal{C}}\Lambda}(x_1, \dots, x_{m-1}, x_{m+1}, \dots, x_N; \alpha),$$

where $\epsilon_m = (-1)^{m(m-1)/2}$ for types AA and AS, while $\epsilon_m = 1$ for types SA and SS.

Proof. The removal of a column follows immediately from Lemma 2.4.4. For types SA and SS, the removal of a circle follows from the stability property given in Proposition 2.4.7.

It remains to prove the removal of a circle for types AA and AS. Only the AS case is detailed below. Let $\lambda = (\Lambda_1, \dots, \Lambda_m)$, $\mu = (\Lambda_{m+1}, \dots, \Lambda_N)$, $\lambda^- = (\Lambda_m, \dots, \Lambda_1)$, $\mu^- = (\Lambda_N, \dots, \Lambda_{m+1})$. Let also $\eta = (\lambda^-, \mu^-)$ and $\eta_- = (\lambda_-, \mu^-)$, where $\lambda_- = (\Lambda_{m-1}, \dots, \Lambda_1)$. By definition,

$$P_{\Lambda}^{AS}(x) = \frac{(-1)^{(m)(m-1)/2}}{f_{\mu}} \text{Asym}_I \text{Sym}_J E_{\eta}(x; \alpha)$$

As mentioned before Asym_I and Sym_J commute. The symmetrization operator can be decomposed as

$$\text{Asym}_I = \text{Asym}_{I_-} (1 - K_{1,m} - K_{2,m} - \dots - K_{m-1,m}),$$

where $I_- = \{1, \dots, m-1\}$ and

$$K_{i,m} = K_i K_{i+1} \dots K_{m-2} K_{m-1} K_{m-2} \dots K_{i+1} K_i.$$

Now, recalling equation (2.3.4) and the second stability property for the non-symmetric Jack polynomials, given in Lemma 2.3.2, we conclude that

$$K_{m-1} K_{m-2} \dots K_{i+1} K_i E_{\eta} \Big|_{x_m=0} = \begin{cases} 0, & \eta_i > 0, \\ E_{\eta_-}(x_1, \dots, x_{N-1}), & \eta_i = 0. \end{cases}$$

From the previous line, we can see that the only nonzero contribution comes from the permutation $K_{m-1} K_{m-2} \dots K_2 K_1$. Thus

$$\begin{aligned} & \text{Asym}_I E_{\eta}(x_1, \dots, x_N) \Big|_{x_m=0} \\ &= \text{Asym}_{I_-} (K_1 K_2 \dots K_{m-2} E_{\eta_-}(x_1, \dots, x_{m-1}, x_{m+1}, \dots, x_N)) \\ &= (-1)^{m-2} \text{Asym}_{I_-} E_{\eta_-}(x_1, \dots, x_{m-1}, x_{m+1}, \dots, x_N) \end{aligned}$$

and the proposition follows. \square

The next proposition shows that just as the non-symmetric Jack polynomials are eigenfunctions of the Sekiguchi operators, also the Jack polynomials with prescribed symmetry are eigenfunctions of the Sekiguchi operators.

Proposition 2.4.9 (Eigenfunctions). *Let Λ be a superpartition of bidegree $(n|m)$. The Jack polynomial with prescribed symmetry, $P_\Lambda = P_\Lambda(x; \alpha)$, is an eigenfunction of the Sekiguchi operators $S^*(u)$ and $S^\otimes(u, v)$ defined in equation (1.5.1). Moreover,*

$$S^*(u) P_\Lambda = \varepsilon_{\Lambda^*}(\alpha, u) P_\Lambda \quad S^\otimes(u, u) P_\Lambda = \varepsilon_{\Lambda^\otimes}(\alpha, u) P_\Lambda,$$

where the eigenvalues are given by equation (1.5.2).

Proof. This lemma immediate follows from the following three basic facts:

- (1) P_Λ is proportional to $\mathcal{O}_{I,J} E_\lambda$ for any composition λ such that $\Lambda = \varphi_m(\lambda)$;
- (2) The operators S^* and S^\otimes commute with $\mathcal{O}_{I,J}$.
- (3) By virtue of Lemma 2.3.3, E_λ is an eigenfunction of $S^*(u)$ and $S^\otimes(u, v)$. Moreover, if $\varphi_m(\lambda) = \Lambda$, then $S^*(u) E_\lambda = \varepsilon_{\Lambda^*}(\alpha, u) E_\lambda$ and $S^\otimes(u, u) E_\lambda = \varepsilon_{\Lambda^\otimes}(\alpha, u) E_\lambda$.

□

Theorem 2.4.10 (Uniqueness at generic α). *Let Λ be a superpartition of bidegree $(n|m)$. Suppose that α is a formal parameter or a complex number that is neither zero nor a negative rational. Then, the Jack polynomial with prescribed symmetry P_Λ is the unique polynomial satisfying*

$$(B1) \quad P_\Lambda = m_\Lambda + \sum_{\Gamma < \Lambda} c_{\Lambda, \Gamma} m_\Gamma, \quad c_{\Lambda, \Gamma} \in \mathbb{C}(\alpha);$$

$$(B2) \quad \mathcal{H} P_\Lambda = d_\Lambda P_\Lambda \quad \text{and} \quad \mathcal{I} P_\Lambda = e_\Lambda P_\Lambda.$$

for some $c_{\Lambda, \Gamma}, d_\Lambda, e_\Lambda \in \mathbb{C}(\alpha)$. Moreover, the eigenvalues d_Λ and e_Λ can be computed explicitly, they will be given in equations (2.4.17) and (2.4.18) respectively.

Proof. We want to prove that the Jack polynomials with prescribed symmetry are the unique unitriangular eigenfunctions of $\mathcal{H} = \sum_{i=1}^N \xi_i^2$ and $\mathcal{I} = \sum_{i=1}^m \xi_i$. However, according to Propositions 2.4.5 and 2.4.9, we already know that the Jack polynomial with prescribed symmetry P_Λ satisfies

$$(B1) \quad P_\Lambda = m_\Lambda + \sum_{\Gamma < \Lambda} c_{\Lambda, \Gamma} m_\Gamma;$$

$$(B2) \quad \mathcal{H} P_\Lambda = d_\Lambda P_\Lambda \quad \text{and} \quad \mathcal{I} P_\Lambda = e_\Lambda P_\Lambda.$$

Thus, it remains to prove that there is no other polynomial that satisfies (B1) and (B2).

First, we need to determine precisely the eigenvalues d_Λ and e_Λ . We recall that m_Λ is proportional to $\mathcal{O}_{I,J}x^\eta$, where $\eta = (\Lambda_m, \dots, \Lambda_1, \Lambda_N, \dots, \Lambda_{m+1})$. Now, as is well known (e.g., see conditions (A1') and (A2') in Section 2.2),

$$\xi_i x^\eta = \bar{\eta}_i x^\eta + \sum_{\gamma \prec \eta} f_{\eta, \gamma} x^\gamma.$$

Then, for any polynomial g such that $g(\xi_1, \dots, \xi_N)$ commutes with $\mathcal{O}_{I,J}$, we have

$$\begin{aligned} g(\xi_1, \dots, \xi_N) m_\Lambda &\propto \mathcal{O}_{I,J} g(\xi_1, \dots, \xi_N) x^\eta \\ &= \mathcal{O}_{I,J} \left(g(\bar{\eta}_1, \dots, \bar{\eta}_N) x^\eta + \sum_{\gamma \prec \eta} f'_{\eta, \gamma} x^\gamma \right) \propto g(\bar{\eta}_1, \dots, \bar{\eta}_N) m_\Lambda + \sum_{\Gamma < \Lambda} f''_{\Lambda, \Omega} m_\Omega. \end{aligned} \quad (2.4.16)$$

Consequently, a triangular polynomial $Q_\Lambda = m_\Lambda + \sum_{\Gamma < \Lambda} c'_{\Lambda, \Gamma} m_\Gamma$, can be an eigenfunction of $g(\xi_1, \dots, \xi_N)$ only if its eigenvalue is equal to $g(\bar{\eta}_1, \dots, \bar{\eta}_N)$. In our case, Q is an eigenfunction of \mathcal{H} and \mathcal{I} , with respective eigenvalues d_Λ and e_Λ , only if

$$d_\Lambda = \sum_{i=1}^N \bar{\eta}_i^2 \quad \text{and} \quad e_\Lambda = \sum_{i=1}^m \bar{\eta}_i.$$

Now, as explained in Lemma 2.3.3, $\sum_{i=1}^N \bar{\eta}_i^2 = \sum_{i=1}^n (\alpha \Lambda_i^* - (i-1))^2$. By comparing the latter equation with the explicit expression for the quantity $\varepsilon_\Lambda(\alpha)$, introduced in Lemma 2.1.1, we get

$$d_\Lambda = 2\alpha \varepsilon_{\Lambda^*}(\alpha) + \alpha^2 |\Lambda^*| + \frac{N(N-1)(2N-1)}{6}. \quad (2.4.17)$$

Returning to the second eigenvalue, we note that because

$\eta = (\Lambda_m, \dots, \Lambda_1, \Lambda_N, \dots, \Lambda_{m+1})$, we can write

$$\sum_{i=1}^m \bar{\eta}_i = \sum_i^m (\alpha \Lambda_i - \#\{j \mid \Lambda_j \geq \Lambda_i\}).$$

From the comparison of the latter expression with the quantity $\varepsilon_\Lambda(\alpha)$, given in Lemma 2.1.4, we then conclude that

$$e_\Lambda = \varepsilon_\Lambda(\alpha). \quad (2.4.18)$$

Second, we suppose that there is another $Q_\Lambda = m_\Lambda + \sum_{\Gamma < \Lambda} c'_{\Lambda, \Gamma} m_\Gamma$ such that (i) $P_\Lambda - Q_\Lambda \neq 0$, (ii) $\mathcal{H}Q_\Lambda = d_\Lambda Q_\Lambda$, and (iii) $\mathcal{I}Q_\Lambda = e_\Lambda Q_\Lambda$. Condition (i) implies that there is superpartition Ω such that $\Omega < \Lambda$ and

$$P_\Lambda - Q_\Lambda = a_\Omega m_\Omega + \sum_{\substack{\Gamma < \Lambda \\ \Gamma <_t \Omega}} a_{\Omega, \Gamma} m_\Gamma,$$

where $<_t$ denotes some total order compatible with the dominance order. The substitution of the last equation into conditions (ii) and (iii) then leads to

$$\mathcal{H}\left(a_\Omega m_\Omega + \sum_{\substack{\Gamma < \Lambda \\ \Gamma <_t \Omega}} a_{\Omega, \Gamma} m_\Gamma\right) = d_\Lambda \left(a_\Omega m_\Omega + \sum_{\substack{\Gamma < \Lambda \\ \Gamma <_t \Omega}} a_{\Omega, \Gamma} m_\Gamma\right) \quad (2.4.19)$$

$$\mathcal{I}\left(a_\Omega m_\Omega + \sum_{\substack{\Gamma < \Lambda \\ \Gamma <_t \Omega}} a_{\Omega, \Gamma} m_\Gamma\right) = e_\Lambda \left(a_\Omega m_\Omega + \sum_{\substack{\Gamma < \Lambda \\ \Gamma <_t \Omega}} a_{\Omega, \Gamma} m_\Gamma\right). \quad (2.4.20)$$

However, according to equation (2.4.16), we have $\mathcal{H}m_\Omega = d_\Lambda m_\Lambda + \dots$ and $\mathcal{I}m_\Omega = e_\Lambda m_\Lambda + \dots$, where the ellipsis \dots stand for linear combinations of monomial indexed by superpartitions strictly smaller than Ω in the dominance order. Consequently, equations (2.4.19) and (2.4.20) can be rewritten as

$$\begin{aligned} d_\Omega a_\Omega m_\Omega + \text{independent terms} &= d_\Lambda a_\Omega m_\Omega + \text{independent terms}, \\ e_\Omega a_\Omega m_\Omega + \text{independent terms} &= e_\Lambda a_\Omega m_\Omega + \text{independent terms}, \end{aligned}$$

which is possible only if

$$d_\Lambda = d_\Omega \quad \text{and} \quad e_\Lambda = e_\Omega$$

On the one hand, using Lemma 2.1.1 and $\Lambda > \Omega$, we conclude that the first equality is possible only if $\Lambda^* = \Omega^*$. On the other hand, Lemma 2.1.4 and $\Lambda > \Omega$ imply that, the second equality is possible only if $\Lambda^* > \Omega^*$. We thus have a contradiction. Therefore, there is no polynomial Q_Λ satisfying (i), (ii), and (iii). We have proved the uniqueness of the polynomial satisfying (B1) and (B2). \square

CHAPTER 3

REGULARITY AND UNIQUENESS PROPERTIES AT $\alpha = -(k+1)/(r-1)$

As mentioned in the Introduction, regularity and uniqueness are not obvious at all if α is a negative rational. Here we find sufficient conditions that allow to preserve these two properties. We indeed prove that if $\alpha = -(k+1)/(r-1)$ and Λ is (k, r, N) -admissible, then the associated Jack polynomial with prescribed symmetry is regular and can be characterized as the unique triangular eigenfunction to differential operator of Sekiguchi type. Similar results hold for a particular family of non-symmetric Jack polynomials indexed by compositions formed by the concatenation of two partitions and with an admissibility condition. We use them at the end of the section to prove the clustering properties for $k = 1$ of the Jack polynomials with prescribed symmetry. This chapter is based on [20, Section 3].

3.1 MORE ON ADMISSIBLE SUPERPARTITIONS

In this subsection we enunciate some lemmas related to the superpartition's admissibility condition, which are necessary to simplify the proofs of the regularity and uniqueness propositions.

Lemma 3.1.1. *Let Λ be a weakly (k, r, N) -admissible and strict superpartition. Then both Λ^* and Λ^\circledast are $(k+1, r, N)$ -admissible.*

Proof. According to the weak admissibility condition, we have $\Lambda_{i+1}^\circledast - \Lambda_{i+1+k}^* \geq r$, so that $\Lambda_i^* - \Lambda_{i+1+k}^* \geq \Lambda_{i+1}^* - \Lambda_{i+1+k}^* \geq r-1$. Now, the equality $\Lambda_{i+1}^* - \Lambda_{i+1+k}^* = r-1$ holds if and only if $\Lambda_{i+1}^\circledast = \Lambda_{i+1}^* + 1$. However, in the latter case, $\Lambda_i^* \geq \Lambda_{i+1}^\circledast > \Lambda_{i+1}^*$. We therefore have $\Lambda_i^* - \Lambda_{i+k+1}^* \geq r$.

Similarly, we have $\Lambda_i^\circledast - \Lambda_{i+k}^\circledast \geq r - 1$. The equality $\Lambda_i^\circledast - \Lambda_{i+k}^\circledast = r - 1$ occurs if and only if $\Lambda_{i+k}^\circledast = \Lambda_{i+k}^* + 1$, but in this case, $\Lambda_{i+k}^\circledast > \Lambda_{i+k}^* > \Lambda_{i+k+1}^\circledast$. Therefore, $\Lambda_i^\circledast - \Lambda_{i+k+1}^\circledast \geq r$. \square

Lemma 3.1.2. *If Λ is (k, r, N) -admissible, then*

$$\Lambda_{i+1}^\circledast - \Lambda_{i+\rho(k+1)}^* \geq \rho r, \quad 1 \leq i \leq N - \rho(k+1), \rho \in \mathbb{Z}_+, \quad (3.1.1)$$

or equivalently,

$$\Lambda_{i-\rho(k+1)}^\circledast - \Lambda_{i-1}^* \geq \rho r, \quad \rho(k+1) \leq i - 1 \leq N, \rho \in \mathbb{Z}_+. \quad (3.1.2)$$

In particular, if Λ is moderately (k, r, N) -admissible, then equations (3.1.1) and (3.1.2) hold.

Proof. The moderately and strongly admissible cases are trivial. We thus suppose that Λ is strict and weakly (k, r, N) -admissible. Firstly, note that the case $\rho = 1$ corresponds to $\Lambda_{i+1}^\circledast - \Lambda_{i+k+1}^* \geq r$, which is an immediate consequence of weak admissibility condition. Secondly, suppose that Eq. (3.1.1) is true for some $\rho \geq 1$. Then,

$$\begin{aligned} \Lambda_{i+1}^\circledast - \Lambda_{i+(\rho+1)(k+1)}^* &= \Lambda_{i+1}^\circledast - \Lambda_{i+\rho(k+1)}^* + \Lambda_{i+\rho(k+1)}^* - \Lambda_{i+(\rho+1)(k+1)}^* \\ &\geq \rho r + \Lambda_{i+\rho(k+1)}^* - \Lambda_{i+(\rho+1)(k+1)}^*. \end{aligned}$$

However, according to the previous lemma, $\Lambda_{i+\rho(k+1)}^* - \Lambda_{i+(\rho+1)(k+1)}^* \geq r$. Consequently,

$$\Lambda_{i+1}^\circledast - \Lambda_{i+(\rho+1)(k+1)}^* \geq \rho r + r,$$

and the lemma follows by induction. \square

3.2 REGULARITY FOR NON-SYMMETRIC JACK POLYNOMIALS

To begin this subsection, we would like to illustrate the importance of the regularity property when α specialized. For this, let us write explicitly the first non trivial non-symmetric Jack polynomial, namely

$$E_{(1,0)}(x_1, x_2; \alpha) = x_1 + \frac{x_2}{\alpha + 1}.$$

We can see from this example that already by considering a minimal degree, such polynomials can have singularities when α is specialized.

However, as mentioned above, we need to find sufficient conditions on the composition's shape that allow us to specialize to a particular α . For this purpose it is necessary to introduce some notation. Given a cell $s = (i, j)$ in the diagram associated to η a composition, we set

$$d_\eta(s) = \alpha(a_\eta(s) + 1) + l_\eta(s) + l'_\eta(s) + 1$$

where $a_\eta(s)$, $l_\eta(s)$ and $l'_\eta(s)$ were given in eq. (2.1.1). According to the results given in [47], we know that $\left(\prod_{s \in \eta} d_\eta(s)\right) E_\eta$ belongs to $\mathbb{N}[\alpha, x_1, \dots, x_N]$. Then, if we want to show that $E_\eta(x; \alpha)$ has no poles at $\alpha = \alpha_{k,r}$, is sufficient to prove that

$$\prod_{s \in \eta} d_\eta(s) \neq 0 \quad \text{if} \quad \alpha = \alpha_{k,r}.$$

Hence, to demonstrate that some non-symmetric Jack polynomials have no poles, we use the relationship between η and its associated superpartition to get an expression of d_η in terms of Λ (the associated superpartition) and then we impose an admissibility condition over Λ to get the regularity's result.

In what follows, $\lambda^+ = (\lambda_1^+, \dots, \lambda_m^+)$ and $\mu^+ = (\mu_1^+, \dots, \mu_{N-m}^+)$ denote partitions. This notation is used in order to avoid confusion between partitions and compositions. Moreover, the composition obtained by the concatenation of λ^+ and μ^+ , which is $(\lambda_1^+, \dots, \lambda_m^+, \mu_1^+, \dots, \mu_{N-m}^+)$, will be denoted by

$$\eta = (\lambda^+, \mu^+). \tag{3.2.1}$$

Lemma 3.2.1. *Let η be as in (3.2.1) and let $\Lambda = \varphi_m(\eta)$ be its associated superpartition. Moreover, let $\text{BF}(\Lambda)$ be the set of cells belonging simultaneously to a bosonic row (without circle) and a fermionic column (with circle). Then,*

$$\prod_{s \in \eta} d_\eta(s) = \prod_{s' \in \text{BF}(\Lambda)} (\alpha(a_{\Lambda^*}(s') + 1) + l_{\Lambda^\circ}(s') + 1) \prod_{s' \in \Lambda^*/\text{BF}(\Lambda)} (\alpha(a_{\Lambda^*}(s') + 1) + l_{\Lambda^*}(s') + 1)$$

Proof. Given a cell $s = (i, j)$ in η , let $s' = (i', j)$ be the associated cell in Λ . We want to express $d_\eta(s)$ as a function of the arm-length and leg-length of the cell s' in Λ . For each cell $s = (i, j)$ in η , we have $a_\eta(s) = a_{\Lambda^*}(s')$, while we can rewrite $l_\eta(s) + l'_\eta(s)$ as

$$\begin{aligned} l_\eta(s) + l'_\eta(s) &= \#\{k = 1, \dots, i-1 \mid j = \eta_k + 1\} \\ &\quad + \#\{k = 1, \dots, i-1 \mid j \leq \eta_k \leq \eta_i - 1\} + \#\{k = i+1, \dots, N \mid j \leq \eta_k \leq \eta_i\}. \end{aligned} \quad (3.2.2)$$

The two last terms can be easily expressed $l_\eta(s) + l'_\eta(s)$ with the help of the leg-length of the cell s' :

$$\#\{k = 1, \dots, i-1 \mid j \leq \eta_k \leq \eta_i - 1\} + \#\{k = i+1, \dots, N \mid j \leq \eta_k \leq \eta_i\} = l_{\Lambda^*}(s'). \quad (3.2.3)$$

However, for the first term, we have to distinguish two cases:

- (i) If $s = (i, j)$ is such that $j = \eta_k + 1$ for some $1 \leq k \leq i-1$, then it is clear that $s' \in BF(\Lambda)$. Moreover,

$$\#\{k = 1, \dots, i-1 \mid j = \eta_k + 1\} = \#\{k = 1, \dots, m \mid j = \lambda_k + 1\}.$$

Since $\#\{k = 1, \dots, m \mid j = \lambda_k + 1\}$ counts the number of circles that appear in the column j in Λ —more specifically, in the leg-length of the cell s' —we conclude that $l_\eta(s) + l'_\eta(s) = l_{\Lambda^\circledast}(s')$. Thus,

$$d_\eta(s) = \alpha(a_{\Lambda^*}(s') + 1) + l_{\Lambda^\circledast}(s') + 1. \quad (3.2.4)$$

- (ii) If $s = (i, j)$ is such that $j \neq \eta_k + 1$ for each $k = 1, \dots, i-1$, then it is clear that $s' \in \Lambda^*/BF(\Lambda)$ and also $l_\eta(s) + l'_\eta(s) = l_{\Lambda^*}(s')$. Hence, we conclude that

$$d_\eta(s) = \alpha(a_{\Lambda^*}(s') + 1) + l_{\Lambda^*}(s') + 1. \quad (3.2.5)$$

The substitution of equations (3.2.3)–(3.2.5) into (3.2.2) completes the proof. \square

Lemma 3.2.2. *Let η be as in (3.2.1) and let $\Lambda = \varphi_m(\eta)$ be its associated superpartition. If Λ is strict and weakly (k, r, N) -admissible or moderately (k, r, N) -admissible, then $E_\eta(x; \alpha)$ does not have poles at $\alpha = \alpha_{k,r}$.*

Proof. As we have mentioned earlier (see [47]), to prove that $E_\eta(x; \alpha)$ has no poles at $\alpha = \alpha_{k,r}$, it is sufficient to show that $\prod_{s \in \eta} d_\eta(s) \neq 0$ if $\alpha = \alpha_{k,r}$.

Let us suppose that $\prod_{s \in \eta} d_\eta(s) = 0$ when $\alpha = \alpha_{k,r}$. From the equality obtained in Corollary 3.2.1, we have $\prod_{s \in \eta} d_\eta(s) = 0$ iff

$$\prod_{s \in \text{BF}(\Lambda)} (\alpha(a_{\Lambda^*}(s)+1) + l_{\Lambda^\otimes}(s)+1) = 0 \quad \text{or} \quad \prod_{s \in \Lambda^*/\text{BF}(\Lambda)} (\alpha(a_{\Lambda^*}(s)+1) + l_{\Lambda^*}(s)+1) = 0.$$

Now, this is possible iff there exists a cell $s \in \text{BF}(\Lambda)$ such that $\alpha(a_{\Lambda^*}(s)+1) + l_{\Lambda^\otimes}(s)+1 = 0$ or if there exists a cell $s \in \Lambda^*/\text{BF}(\Lambda)$ such that $\alpha(a_{\Lambda^*}(s)+1) + l_{\Lambda^*}(s)+1 = 0$.

First, we suppose that $s = (i, j) \in \text{BF}(\Lambda)$. Now $\alpha(a_{\Lambda^*}(s)+1) + l_{\Lambda^\otimes}(s)+1 = 0$ iff there exists a $\rho \in \mathbb{Z}_+$ such that $a_{\Lambda^*}(s)+1 = \rho(r-1)$ and $l_{\Lambda^\otimes}(s)+1 = \rho(k+1)$. Using both relations and expressing them in terms of the components of Λ , we get

$$\Lambda_i^* - \Lambda_{i+\rho(k+1)-1}^\otimes + 1 = \rho(r-1).$$

Moreover, we have by hypothesis, $\Lambda_i^* = \Lambda_i^\otimes$ (bosonic row), so that the previous line can be rewritten as

$$\rho(r-1) - 1 = \Lambda_i^\otimes - \Lambda_{i+\rho(k+1)-1}^\otimes.$$

However, by using Lemma 3.1.2, we also get

$$\Lambda_i^\otimes - \Lambda_{i+\rho(k+1)-1}^\otimes \geq \rho r - 1,$$

which contradicts the previous equality.

Second, we suppose that there is a cell $s = (i, j) \in \Lambda^*/\text{BF}(\Lambda)$ such that $\alpha(a_{\Lambda^*}(s)+1) + l_{\Lambda^*}(s)+1 = 0$. This is possible iff there exists a $\rho \in \mathbb{Z}_+$ such that $a_{\Lambda^*}(s)+1 = \rho(r-1)$ and $l_{\Lambda^*}(s)+1 = \rho(k+1)$. As in the previous case, using both relations and expressing them in terms of the components of Λ , we obtain

$$\rho(r-1) - 1 \geq \Lambda_i^* - \Lambda_{i+\rho(k+1)-1}^* \geq \rho r - 1$$

which is in contradiction with the admissibility condition of Λ (see Lemma 3.1.2).

Therefore, whenever $\alpha = \alpha_{k,r}$ and Λ is (k, r, N) -admissible, we have

$\prod_{s \in \eta} d_\eta(s) \neq 0$, as expected. □

Remark 3.2.3. *The set BF will be illustrated diagrammatically in Appendix C.*

3.3 REGULARITY FOR JACK POLYNOMIALS WITH PRESCRIBED SYMMETRY

We recall that $\lambda^+ = (\lambda_1^+, \dots, \lambda_m^+)$ and $\mu^+ = (\mu_1^+, \dots, \mu_{N-m}^+)$ are partitions. Similarly, $\lambda^- = (\lambda_m^+, \dots, \lambda_1^+)$ and $\mu^- = (\mu_{N-m}^+, \dots, \mu_1^+)$ denote compositions whose elements are written in increasing order. The concatenation of λ^- and μ^- is given by

$$(\lambda^-, \mu^-) = (\lambda_m^+, \dots, \lambda_1^+, \mu_{N-m}^+, \dots, \mu_1^+).$$

As shown below, the regularity for Jack polynomials with prescribed symmetry cannot be established directly using Definition 1.3. Indeed, a non-symmetric Jack polynomials indexed by a composition η of the form (λ^-, μ^-) is in general singular at $\alpha = \alpha_{k,r}$, even if η is associated to an admissible superpartition, as we will see in the following example. Given $k = 1$, $r = 2$ and $N = 3$, we consider the compositions $\eta^+ = (2, 1, 0)$ and $\eta^- = (0, 1, 2)$, so we have the polynomials:

$$\begin{aligned} E_{(2,1,0)}(x_1, x_2, x_3; \alpha) &= x_1^2 x_2 + \frac{1}{\alpha+1} x_1 x_2^2 + \frac{1}{\alpha+1} x_1^2 x_3 + \frac{1}{(\alpha+1)^2} x_1 x_3^2 \\ &+ \frac{1}{(\alpha+1)^2} x_2^2 x_3 + \frac{\alpha^2 + 2\alpha + 2}{2(\alpha+1)^3} x_2 x_3^2 + \frac{(\alpha+2)(2\alpha+3)}{2(\alpha+1)^3} x_1 x_2 x_3 \\ E_{(0,1,2)}(x_1, x_2, x_3; \alpha) &= x_2 x_3^2 + \frac{1}{\alpha+2} x_1 x_2 x_3 \end{aligned}$$

and we see that if we specialize $\alpha = -(k+1)/(r-1) = -2$ the polynomial E_{η^-} has a singularity, while that E_{η^+} has no singularities at $\alpha = -2$. We thus need to use another normalization for the Jack polynomials with prescribed symmetry, which we state in the following proposition.

Proposition 3.3.1. *Let $\eta = (\lambda^+, \mu^+)$ and $\Lambda = \varphi_m(\eta)$. Suppose that α is generic. Then*

$$\begin{aligned} P_{\Lambda}^{\text{AS}}(x; \alpha) &= \frac{c_{\Lambda}^{\text{AS}}}{C_{\Lambda}^{\text{AS}}} \text{Asym}_I \text{Sym}_J E_{\eta}, & P_{\Lambda}^{\text{SS}}(x; \alpha) &= \frac{c_{\Lambda}^{\text{SS}}}{C_{\Lambda}^{\text{SS}}} \text{Sym}_I \text{Sym}_J E_{\eta}, \\ P_{\Lambda}^{\text{SA}}(x; \alpha) &= \frac{c_{\Lambda}^{\text{SA}}}{C_{\Lambda}^{\text{SA}}} \text{Sym}_I \text{Asym}_J E_{\eta}, & P_{\Lambda}^{\text{AA}}(x; \alpha) &= \frac{c_{\Lambda}^{\text{AA}}}{C_{\Lambda}^{\text{AA}}} \text{Asym}_I \text{Asym}_J E_{\eta}, \end{aligned}$$

where

$$\begin{aligned}
 C_{\Lambda}^{\text{AS}} &= (-1)^{m(m-1)/2} \prod_{s \in \text{FF}^*(\Lambda)} \frac{\alpha a_{\Lambda^{\otimes}}(s) + l_{\Lambda^{\otimes}}(s) - 1}{\alpha a_{\Lambda^{\otimes}}(s) + l_{\Lambda^{\otimes}}(s)} \\
 &\quad \times \prod_{\substack{s=(i,j) \in \text{BRDB} \\ 0 \leq \gamma \leq \#\{t > i | \Lambda_t^{\otimes} - \Lambda_t^* = 0, \Lambda_t^* = i\} - 1}} \frac{\alpha a_{\Lambda^*}(s) + l_{\Lambda^*}(s) - \gamma + 1}{\alpha a_{\Lambda^*}(s) + l_{\Lambda^*}(s) - \gamma}, \\
 C_{\Lambda}^{\text{SS}} &= \prod_{\substack{s=(i,j) \in \text{FF}^*(\Lambda) \\ 0 \leq \gamma \leq \#\{t > i | \Lambda_t^{\otimes} - \Lambda_t^* = 1, \Lambda_t^* = i\} - 1}} \frac{\alpha a_{\Lambda^{\otimes}}(s) + l_{\Lambda^{\otimes}}(s) - \gamma + 1}{\alpha a_{\Lambda^{\otimes}}(s) + l_{\Lambda^{\otimes}}(s) - \gamma} \\
 &\quad \times \prod_{\substack{s=(i,j) \in \text{BRDB} \\ 0 \leq \gamma' \leq \#\{t > i | \Lambda_t^{\otimes} - \Lambda_t^* = 0, \Lambda_t^* = i\} - 1}} \frac{\alpha a_{\Lambda^*}(s) + l_{\Lambda^*}(s) - \gamma' + 1}{\alpha a_{\Lambda^*}(s) + l_{\Lambda^*}(s) - \gamma'}, \\
 C_{\Lambda}^{\text{SA}} &= (-1)^{(N-m)(N-m-1)/2} \prod_{\substack{s=(i,j) \in \text{FF}^*(\Lambda) \\ 0 \leq \gamma \leq \#\{t > i | \Lambda_t^{\otimes} - \Lambda_t^* = 1, \Lambda_t^* = i\} - 1}} \frac{\alpha a_{\Lambda^{\otimes}}(s) + l_{\Lambda^{\otimes}}(s) - \gamma + 1}{\alpha a_{\Lambda^{\otimes}}(s) + l_{\Lambda^{\otimes}}(s) - \gamma} \\
 &\quad \times \prod_{s \in \text{BRDB}} \frac{\alpha a_{\Lambda^*}(s) + l_{\Lambda^*}(s) - 1}{\alpha a_{\Lambda^*}(s) + l_{\Lambda^*}(s)}, \\
 C_{\Lambda}^{\text{AA}} &= (-1)^{m(m-1)/2} (-1)^{(N-m)(N-m-1)/2} \prod_{s \in \text{FF}^*(\Lambda)} \frac{\alpha a_{\Lambda^{\otimes}}(s) + l_{\Lambda^{\otimes}}(s) - 1}{\alpha a_{\Lambda^{\otimes}}(s) + l_{\Lambda^{\otimes}}(s)} \\
 &\quad \times \prod_{s \in \text{BRDB}} \frac{\alpha a_{\Lambda^*}(s) + l_{\Lambda^*}(s) - 1}{\alpha a_{\Lambda^*}(s) + l_{\Lambda^*}(s)}.
 \end{aligned}$$

Notice that $\text{FF}(\Lambda)$ denotes the set of cells belonging to a fermionic row and a fermionic column, while $\text{FF}^*(\Lambda) = \text{FF}(\Lambda) \setminus \{s | s \in \Lambda^{\otimes}/\Lambda^*\}$. The set BRDB contains all cells (i, j) such that i is a bosonic row, j is the length of some other bosonic row i' satisfying $\Lambda_i^* > \Lambda_{i'}^*$.

Sketch of proof. Let $\eta^- = (\lambda^-, \mu^-)$. The proof consists in calculating the constant of proportionality C_{Λ} such that

$$\mathcal{O}_{I,J} E_{\eta} = C_{\Lambda} \mathcal{O}_{I,J} E_{\eta^-}.$$

Our method follows general arguments that are independent of the symmetry type of the polynomials, so we give the general idea of the proof only for the polynomials of type AS.

We first note that we can recover η from η^- through the following sequence of transpositions:

$$\eta = \tau_2 \cdots \tau_{m-1} \tau_m \omega_{m+2} \cdots \omega_N(\eta^-)$$

where $\tau_r = K_{r-1}K_{r-2}\dots K_1$ and $\omega_r = K_{r-1}K_{r-2}\dots K_{m+1}$, except that in ω_r , we do not consider transpositions K_i such that $\mu_i = \mu_{i+1}$. Thus, we have

$$E_\eta = E_{\tau_2\dots\tau_{m-1}\tau_m\omega_{m+2}\dots\omega_N(\eta^-)}$$

Now, given that we are considering η^- a composition in increasing order, we can use successively the third line of (2.3.4). This yields an expression of the form

$$E_{\tau_2\dots\tau_{m-1}\tau_m\omega_{m+2}\dots\omega_N(\eta^-)} = \mathcal{O}'_I \mathcal{O}'_J \omega_N E_{\eta^-},$$

where the operators \mathcal{O}'_I and \mathcal{O}'_J are such that

$$\text{Asym}_I \mathcal{O}'_I = C'_I, \quad \text{Sym}_J \mathcal{O}'_I = \mathcal{O}'_I \text{Sym}_J, \quad \text{Sym}_J \mathcal{O}'_J = C'_J, \quad \text{Asym}_I \mathcal{O}'_J = \mathcal{O}'_J \text{Asym}_J.$$

The coefficients C'_I and C'_J are obtained by considering all possible combinations of differences of eigenvalues $\bar{\Lambda}_i - \bar{\Lambda}_j$ with $i < j$, $i, j \in \{1, \dots, m\}$ and $\Lambda_i \neq \Lambda_j$ or $i, j \in \{m+1, \dots, N\}$ and $\Lambda_i \neq \Lambda_j$. More specifically,

$$C'_I = (-1)^{m(m-1)/2} \prod_{\substack{i < j, \Lambda_i \neq \Lambda_j \\ i, j \in \{1, \dots, m\}}} \left(1 - \frac{1}{\bar{\Lambda}_i - \bar{\Lambda}_j} \right)$$

while

$$C'_J = \prod_{\substack{i < j, \Lambda_i \neq \Lambda_j \\ i, j \in \{m+1, \dots, N\}}} \left(1 + \frac{1}{\bar{\Lambda}_i - \bar{\Lambda}_j} \right)$$

Rewriting the product $C'_I \cdot C'_J$ in a more compact form finally gives the desired expression for C_Λ^{AS} . \square

Remark 3.3.2. *The sets FF and BRDB will be illustrated diagrammatically in Appendix C.*

Lemma 3.3.3. *Let $\eta = (\lambda^+, \mu^+)$ and $\Lambda = \varphi_m(\eta)$.*

(i) *If Λ is strict and weakly (k, r, N) -admissible, then C_Λ^{AS} has neither zeros nor singularities at $\alpha = \alpha_{k,r}$.*

(ii) *If Λ is moderately (k, r, N) -admissible, then C_Λ^{SS} has neither zeros nor singularities at $\alpha = \alpha_{k,r}$.*

(iii) *If Λ is moderately (k, r, N) -admissible, then C_Λ^{SA} has neither zeros nor singularities at $\alpha = \alpha_{k,r}$.*

(iv) *If Λ is strict and weakly (k, r, N) -admissible, then C_Λ^{AA} has neither zeros nor singularities at $\alpha = \alpha_{k,r}$.*

Sketch of proof. This follows almost immediately from the explicit formulas for the coefficient C_Λ given in the last proposition. All cases are similar. The only noticeable differences are the type of admissibility for each symmetry type and the additional parameter γ , which can be controlled with admissibility condition. Once again, we restrict our demonstration to symmetry type AS.

Consider C_Λ^{AS} and suppose that it has singularities or poles at $\alpha = \alpha_{k,r}$. This happens iff there exists a cell $s \in \text{FF}^*$ such that $\alpha a_{\Lambda^\otimes}(s) + l_{\Lambda^\otimes}(s) = 0$ or a cell $s \in \text{BRDB}$ such that $\alpha a_{\Lambda^*}(s) + l_{\Lambda^*}(s) - \gamma = 0$ for some $0 \leq \gamma \leq \#\{t > i | \Lambda_t^* = \Lambda_i^*\}$.

First, assume that $s = (i, j) \in \text{FF}^*$. Note that $\alpha a_{\Lambda^\otimes}(s) + l_{\Lambda^\otimes}(s) = 0$ iff there exists a positive integer ρ such that $a_{\Lambda^\otimes}(s) = \rho(r-1)$ and $l_{\Lambda^\otimes}(s) = \rho(k+1)$. Using these two relations and expressing them in terms of the components of Λ , we find

$$\Lambda_i^\otimes - \Lambda_{i+\rho(k+1)}^\otimes = \rho(r-1). \quad (3.3.1)$$

Now, the weak admissibility condition and Lemma 3.1.1 imply that

$$\rho(r-1) = \Lambda_i^\otimes - \Lambda_{i+\rho(k+1)}^\otimes \geq \rho r. \quad (3.3.2)$$

Equations (3.3.1) and (3.3.2) are contradictory. Hence, the first factor of C_Λ^{AS} does not have singularities.

Now, assume $s \in \text{BRDB}$. Following a similar argument, we conclude that the second factor has no singularity.

In the same way, one can show that C_Λ has no zero. □

Proposition 3.3.4 (Regularity). *Let Λ be a (k, r, N) -admissible superpartition. Then, $P_\Lambda(x_1, \dots, x_N; \alpha)$ is regular at $\alpha = \alpha_{k,r}$.*

Proof. Let $\eta = (\lambda^+, \mu^+)$ and $\Lambda = \varphi_m(\eta)$. According to Proposition 3.3.1, for any symmetry type, there are coefficients c_Λ and C_Λ such that

$$P_\Lambda(x; \alpha) = \frac{c_\Lambda}{C_\Lambda} \mathcal{O}_{I,J} E_\eta(x; \alpha)$$

The coefficient c_Λ is independent of α , so it is trivially regular at $\alpha = \alpha_{k,r}$. Given that Λ is admissible, Lemma 3.3.3 implies that C_Λ^{-1} is also regular at $\alpha = \alpha_{k,r}$.

Finally, by Lemma 3.2.2, the non-symmetric Jack polynomial $E_\eta(x; \alpha)$ is regular at $\alpha = \alpha_{k,r}$. Therefore, limit

$$\lim_{\alpha \rightarrow \alpha_{k,r}} \frac{c_\Lambda}{C_\Lambda} \mathcal{O}_{I,J} E_\eta(x; \alpha)$$

is well defined and the proposition follows. \square

3.4 UNIQUENESS FOR JACK POLYNOMIALS WITH PRESCRIBED SYMMETRY

Uniqueness of the triangular eigenfunctions of the Sekiguchi operators is a non trivial property when α is not generic. This is due to the high degeneracy of the eigenvalues. Non-symmetric Jack polynomials may have poles only for non-generic values of α , and when poles occur, then there is non-uniqueness. Indeed, following the result of Lemma 2.4 in [31], one easily sees that if the non-symmetric Jack polynomial E_η has a pole at some given value of α_0 , then there exists a composition $\nu \prec \eta$ such that $\varepsilon_{\eta^+}(\alpha_0, u) = \varepsilon_{\nu^+}(\alpha_0, u)$. On the other hand, for non-generic values of α , non-uniqueness may be observed even for regular polynomials. As a basic example, consider the compositions $\eta = (2, 0)$ and $\nu = (1, 1)$, which satisfy $\eta \succ \nu$. One can verify that $E_\eta(x_1, x_2; \alpha)$ and $E_\nu(x_1, x_2; \alpha)$ are regular at $\alpha = 0$. Nevertheless these polynomials share the same eigenvalues, i.e., $\bar{\eta}_j|_{\alpha=0} = \bar{\nu}_j|_{\alpha=0}$ for $j = 1, 2$. Hence, at $\alpha = 0$, any polynomial of the form $E_\eta(x_1, x_2; \alpha) + aE_\nu(x_1, x_2; \alpha)$ satisfies the conditions (A1') and (A2') of Section 2.2, so uniqueness is lost. This motivates us look for a uniqueness criterion like eigenfunctions of the Sekiguchi operators for some specialization of α .

In order to simplify the proofs of the following theorems, we enunciate some lemmas related to different types of admissible superpartitions.

Lemma 3.4.1. *Let Λ be weakly (k, r, N) -admissible and strict. Suppose that for some $\sigma \in S_N$, the superpartition Γ satisfies*

$$\Gamma_i^* = \Lambda_{\sigma(i)}^* + \frac{r-1}{k+1}(\sigma(i) - i),$$

Then,

$$\Lambda_i^* < \Gamma_i^* \implies \sigma(i) < i, \quad \Lambda_i^* = \Gamma_i^* \implies \sigma(i) = i, \quad \Lambda_i^* > \Gamma_i^* \implies \sigma(i) > i.$$

Moreover,

$$\sigma(i) = \begin{cases} i - k - 1 & \text{if } \Lambda_i^* < \Gamma_i^* \quad \text{and} \quad \Lambda_{i-1}^* \geq \Gamma_{i-1}^* \\ i + k + 1 & \text{if } \Lambda_i^* > \Gamma_i^* \quad \text{and} \quad \Lambda_{i+1}^* \leq \Gamma_{i+1}^*. \end{cases}$$

Proof. Obviously, the equality $\Gamma_i^* = \Lambda_{\sigma(i)}^* + \frac{r-1}{k+1}(\sigma(i) - i)$ holds only if there is $\rho \in \mathbb{Z}$ such that $\sigma(i) = i + \rho(k+1)$.

First, we assume that $\Lambda_i^* = \Gamma_i^*$. Then, $\Lambda_i^* = \Lambda_{i \pm \rho(k+1)}^* \pm \rho(r-1)$ for some $\rho \geq 0$. Lemma 3.1.1 implies however that $\Lambda_i^* - \Lambda_{i+\rho(k+1)}^* \geq \rho r$ and $\Lambda_{i-\rho(k+1)}^* - \Lambda_i^* \geq \rho r$. Combining the last relations, we get $\rho(r-1) \geq \rho r$, which implies $\rho = 0$. Consequently, $\Lambda_i^* = \Gamma_i^*$ only if $\sigma(i) = i$.

Next, we assume that $\Lambda_i^* > \Gamma_i^*$. We have three possible cases:

1. $\sigma(i) = i$. This implies that $\Lambda_i^* = \Gamma_i^*$, which contradicts our assumption.
2. $\sigma(i) = i - \rho(k+1)$ for some positive integer ρ . We then have $\Lambda_i^* > \Lambda_{i-\rho(k+1)}^* - \rho(r-1)$. However, according to Lemma 3.1.2, we have $\Lambda_{i-\rho(k+1)}^{\otimes} - \Lambda_i^* \geq \rho r$, so that $\Lambda_{i-\rho(k+1)}^* - \Lambda_i^* \geq \rho r - 1$. Combining these equations, we get $\rho(r-1) > \rho r - 1$, which contradicts the fact that $\rho \geq 1$.
3. $\sigma(i) = i + \rho(k+1)$ for some positive integer ρ . In this case, we do not obtain a contradiction. Hence, $\sigma(i) > i$.

Similar arguments can be used to prove that if $\Lambda_i^* < \Gamma_i^*$, then $\sigma(i) < i$.

To prove the second part of proposition, we suppose that $\Lambda_i^* > \Gamma_i^*$ while $\Lambda_{i+1}^* \leq \Gamma_{i+1}^*$. Now, we know that $\Gamma_{i+1}^* \leq \Gamma_i^*$, where $\Gamma_{i+1}^* = \Lambda_{i+1}^* + \delta$ for some $\delta \geq 0$, and $\Gamma_i^* = \Lambda_{i+\rho(k+1)}^* + \rho(r-1)$ for some $\rho \in \mathbb{Z}_+$. Combining these inequalities, we get $\Lambda_{i+1}^* + \delta \leq \Lambda_{i+\rho(k+1)}^* + \rho(r-1)$. However, $\Lambda_{i+1}^* = \Lambda_{i+1}^{\otimes} - \epsilon$ where $\epsilon = 0, 1$. Thus, $\Lambda_{i+1}^{\otimes} - \Lambda_{i+\rho(k+1)}^* \leq \rho(r-1) - \delta + \epsilon$. By making use of Lemma 3.1.2, we get $\rho r \leq \rho(r-1) - \delta + \epsilon$, which implies that $\epsilon = 1$, $\delta = 0$ and $\rho = 1$. Therefore, $\Lambda_i^* > \Gamma_i^*$ and $\Lambda_{i+1}^* \leq \Gamma_{i+1}^*$ imply $\sigma(i) = i - k - 1$. The case where $\Lambda_i^* < \Gamma_i^*$ and $\Lambda_{i+1}^* \geq \Gamma_{i+1}^*$ is proved analogously. \square

Lemma 3.4.2. *Let Λ be moderately or strongly (k, r, N) -admissible. Suppose that for some $\omega \in S_N$, the superpartition Γ satisfies*

$$\Gamma_i^{\otimes} = \Lambda_{\omega(i)}^{\otimes} + \frac{r-1}{k+1}(\omega(i) - i),$$

Then,

$$\Lambda_i^\circledast < \Gamma_i^\circledast \implies \omega(i) < i, \quad \Lambda_i^\circledast = \Gamma_i^\circledast \implies \omega(i) = i, \quad \Lambda_i^\circledast > \Gamma_i^\circledast \implies \omega(i) > i.$$

Moreover,

$$\omega(i) = \begin{cases} i - k - 1 & \text{if } \Lambda_i^\circledast < \Gamma_i^\circledast \text{ and } \Lambda_{i-1}^* \geq \Gamma_{i-1}^* \\ i + k + 1 & \text{if } \Lambda_i^\circledast > \Gamma_i^\circledast \text{ and } \Lambda_{i+1}^* \leq \Gamma_{i+1}^*. \end{cases}$$

Proof. One essentially follows the same steps as in the proof of Lemma 3.4.1. \square

Lemma 3.4.3. *Let Λ be a (k, r, N) -admissible superpartition and let Γ satisfy*

$$\Gamma_i^* = \Lambda_{\sigma(i)}^* + \frac{r-1}{k+1}(\sigma(i) - i), \quad \Gamma_i^\circledast = \Lambda_{\omega(i)}^\circledast + \frac{r-1}{k+1}(\omega(i) - i)$$

for some $\sigma, \omega \in S_N$. Then, $\sigma = \omega$.

Proof. The cases for which Λ is a strict and weakly (k, r, N) -admissible superpartition or for which Λ is strongly (k, r, N) -admissible superpartition are almost identical, so we only prove the first. We deduce from the hypothesis that $\sigma(i) \equiv i \pmod{k+1}$ and $\omega(i) \equiv i \pmod{k+1}$, so that $\omega(i) = \sigma(i) + t(k+1)$ for some $t \in \mathbb{Z}$.

First, we suppose that $\sigma(i) < \omega(i)$, which implies that $\omega(i) = \sigma(i) + t(k+1)$ for some $t \in \mathbb{Z}_+$. Then,

$$\Gamma_i^\circledast - \Gamma_i^* = \Lambda_{\sigma(i)+t(k+1)}^\circledast - \Lambda_{\sigma(i)}^* + t(r-1).$$

By Lemma 3.1.1, we know that Λ^* is $(k+1, r, N)$ -admissible, which means that $\Lambda_{\sigma(i)}^* - \Lambda_{\sigma(i)+t(k+1)}^* \geq tr$ and $\Lambda_{\sigma(i)}^\circledast - \Lambda_{\sigma(i)+t(k+1)}^\circledast \geq tr - 1$. Combining the inequalities previously obtained, we get

$$0 \leq \Gamma_i^\circledast - \Gamma_i^* \leq 1 - tr + t(r-1) = 1 - t.$$

This inequality is possible only if $t = 1$. We have thus shown that

$$(i) \quad \Gamma_i^\circledast = \Gamma_i^* \quad (ii) \quad \omega(i) = \sigma(i) + k + 1 \quad (iii) \quad \Lambda_{\sigma(i)}^* - \Lambda_{\omega(i)}^\circledast = r - 1.$$

Note that if $\Lambda_{\sigma(i)}^\circledast = \Lambda_{\sigma(i)}^*$, then $\Lambda_{\sigma(i)}^\circledast - \Lambda_{\sigma(i)+k+1}^\circledast = r - 1 \geq r$, which is a contradiction. Similarly, one gets a contradiction by supposing $\Lambda_{\omega(i)}^\circledast = \Lambda_{\omega(i)}^*$. Thus, we also have

$$(iv) \quad \Lambda_{\sigma(i)}^\circledast = \Lambda_{\sigma(i)}^* + 1 \quad (v) \quad \Lambda_{\omega(i)}^\circledast = \Lambda_{\omega(i)}^* + 1.$$

Second, we suppose that $\sigma(i) > \omega(i)$, which implies that $\sigma(i) = \omega(i) + t(k+1)$ for some $t \in \mathbb{Z}_+$. Then

$$\Gamma_i^{\otimes} - \Gamma_i^* = \Lambda_{\omega(i)}^{\otimes} - \Lambda_{\omega(i)+t(k+1)}^* - t(r-1).$$

By Lemma 3.1.2 we know that $\Lambda_{\omega(i)}^{\otimes} - \Lambda_{\omega(i)+t(k+1)}^* \geq tr$, so that

$$1 \geq \Gamma_i^{\otimes} - \Gamma_i^* \geq tr - t(r-1) = t.$$

The latter inequality holds only if $t = 1$. We have thus proved that

$$(vi) \quad \Gamma_i^{\otimes} = \Gamma_i^* + 1 \quad (vii) \quad \sigma(i) = \omega(i) + k + 1 \quad (viii) \quad \Lambda_{\omega(i)}^{\otimes} - \Lambda_{\sigma(i)}^* = r.$$

Moreover, we deduce from (vi) and the admissibility condition, that

$$(ix) \quad \Lambda_{\omega(i)}^{\otimes} = \Lambda_{\omega(i)}^* \quad (x) \quad \Lambda_{\sigma(i)}^{\otimes} = \Lambda_{\sigma(i)}^*.$$

Now, assume that σ and ω do not coincide. Then, there exists a positive integer i such that $\omega(i) > \sigma(i)$, which by virtue of the above discussion, implies that $\omega(i) = \sigma(i) + k + 1$. Let j be such that $\omega(i) = \sigma(i) + k + 1 = \sigma(j)$. Obviously, $i \neq j$ and $\sigma(j) \neq \omega(j)$. Then, according to conclusions (ii) and (vii) above, only cases can occur: $\omega(j) = \sigma(i) + k + 1 \pm (k + 1)$.

- Suppose that $\omega(j) = \sigma(i) + 2(k + 1)$ and let j_2 be such that $\sigma(j_2) = \sigma(i) + 2(k + 1)$, so that $j_2 \neq j$. Then, conclusions (ii) and (vii) above imply that $\omega(j_2) = \sigma(i) + 2(k + 1) \pm (k + 1)$. However, only the case $\omega(j_2) = \sigma(i) + 3(k + 1)$ is possible, since the equality $\omega(j_2) = \sigma(i) + k + 1$ implies the contradiction $j_2 = i$. Similarly, if j_3 is such that $\sigma(j_3) = \sigma(i) + 3(k + 1)$, then $\omega(j_3) = \sigma(i) + 4(k + 1)$. Continuing in this way, one eventually finds a positive integer $\ell < N$ such that $\omega(\ell) > N$, which clearly contradicts the fact that ω is a permutation of $\{1, \dots, N\}$.
- Suppose that $\omega(j) = \sigma(i)$. Recall that by definition, $\sigma(j) = \sigma(i) + k + 1$. Hence, $\omega(j) = \sigma(j) - k - 1 < \sigma(j)$. Conclusion (viii) above then implies that $\Lambda_{\omega(j)}^{\otimes} - \Lambda_{\sigma(j)}^* = r$, which is equivalent to $\Lambda_{\sigma(i)}^{\otimes} - \Lambda_{\omega(i)}^* = r$. However, conclusion (iv) implies that $\Lambda_{\sigma(i)}^{\otimes} = \Lambda_{\sigma(i)}^* + 1$. Combination of the last two equations finally leads to

$$r - 1 = \Lambda_{\sigma(i)}^* - \Lambda_{\omega(i)}^* = \Lambda_{\sigma(i)}^* - \Lambda_{\sigma(i)+k+1}^*.$$

This equation contradicts Lemma 3.1.1.

Therefore, the permutations σ and ω must coincide, as required. \square

Theorem 3.4.4 (Uniqueness at $\alpha = \alpha_{k,r}$). *Let Λ be a (k, r, N) -admissible superpartition of bi-degree $(n|m)$. Assume moreover that $\alpha = \alpha_{k,r}$. Then, the Jack polynomial with prescribed symmetry, here denoted by P_Λ , is the unique polynomial satisfying:*

1. $P_\Lambda = m_\Lambda + \sum_{\Gamma < \Lambda} c_{\Lambda, \Gamma} m_\Gamma, \quad c_{\Lambda, \Gamma} \in \mathbb{C},$
2. $S^*(u)|_{\alpha=\alpha_{k,r}} P_\Lambda = \varepsilon_{\Lambda^*}(\alpha_{k,r}, u) P_\Lambda$ and $S^\circledast(u, u)|_{\alpha=\alpha_{k,r}} P_\Lambda = \varepsilon_{\Lambda^\circledast}(\alpha_{k,r}, u) P_\Lambda.$

Proof. Proceeding as in Theorem 2.4.10, we know that there are more than one polynomials satisfying (1) and (2) only if we can find a superpartition of type \mathbb{T} , say Γ , such that $\Lambda > \Gamma$, $\varepsilon_{\Gamma^*}(\alpha, u) = \varepsilon_{\Lambda^*}(\alpha, u)$, and $\varepsilon_{\Gamma^\circledast}(\alpha, u) = \varepsilon_{\Lambda^\circledast}(\alpha, u)$. Consequently, in order to prove the uniqueness, it is sufficient to show that if $\Gamma < \Lambda$, then $\varepsilon_{\Gamma^*}(\alpha, u) \neq \varepsilon_{\Lambda^*}(\alpha, u)$ or $\varepsilon_{\Gamma^\circledast}(\alpha, u) \neq \varepsilon_{\Lambda^\circledast}(\alpha, u)$.

Let us assume that we are given a superpartition $\Gamma < \Lambda$ such that $\varepsilon_{\Gamma^*}(\alpha, u) = \varepsilon_{\Lambda^*}(\alpha, u)$ and $\varepsilon_{\Gamma^\circledast}(\alpha, u) = \varepsilon_{\Lambda^\circledast}(\alpha, u)$. Obviously, the last two equality holds if and only if there are $\sigma, \omega \in S_N$ such that

$$\Gamma_i^* = \Lambda_{\sigma(i)}^* + \frac{r-1}{k+1}(\sigma(i) - i), \quad \Gamma_i^\circledast = \Lambda_{\omega(i)}^\circledast + \frac{r-1}{k+1}(\omega(i) - i) \quad \forall i. \quad (3.4.1)$$

According to Lemma 3.4.3, equation (3.4.1) holds only if $\sigma = \omega$. Now, we recall that by hypothesis, either $\Gamma^* < \Lambda^*$ or $\Gamma^* = \Lambda^*$ and $\Gamma^\circledast < \Lambda^\circledast$. Only the former case is nontrivial. Indeed, Lemma 3.4.1 implies that if $\Lambda_i^* = \Gamma_i^*$ for all i , then σ is the identity, and so is ω . In short, whenever equation (3.4.1) and $\Gamma^* = \Lambda^*$ hold, we have $\Gamma^\circledast = \Lambda^\circledast$, which is in contradiction with $\Gamma^\circledast < \Lambda^\circledast$. Thus, we must assume that $\Gamma^* < \Lambda^*$, which implies that there exist integers $j > 1$ and $\epsilon > 0$ such that

$$\Gamma_j^* = \Lambda_j^* + \epsilon \quad \text{and} \quad \Gamma_i^* \leq \Lambda_i^*, \quad \forall i < j. \quad (3.4.2)$$

As a consequence of (3.4.1) and Lemma 3.4.3, there is a permutation σ such that $\sigma(j) \neq j$,

$$\Gamma_j^* = \Lambda_{\sigma(j)}^* + \frac{r-1}{k+1}(\sigma(j) - j), \quad \Gamma_j^\circledast = \Lambda_{\sigma(j)}^\circledast + \frac{r-1}{k+1}(\sigma(j) - j), \quad (3.4.3)$$

which is possible only if $\sigma(j) = j \pmod{k+1}$.

1. If $\sigma(j) = j + \rho(k+1)$ for some positive integer ρ , then $\Gamma_j^* = \Lambda_j^* + \epsilon = \Lambda_{j+\rho(k+1)}^* + \rho(r-1)$. However, the latter equation contradicts the hypothesis $\epsilon > 0$ and Lemma 3.1.2, according to which $\Lambda_j^* - \Lambda_{j+\rho(k+1)}^* \geq \rho r - 1$.
2. If $\sigma(j) = j - \rho(k+1)$ for some positive integer ρ , then $\Gamma_j^* = \Lambda_{j-\rho(k+1)}^* - \rho(r-1)$. Moreover, we know that $\Gamma_{j-1}^* = \Lambda_{j-1}^* - \delta$, for some $\delta \geq 0$, and that $\Gamma_{j-1}^* \geq \Gamma_j^*$. Combining these equations, we get $\rho(r-1) \geq \delta + \Lambda_{j-\rho(k+1)}^* - \Lambda_{j-1}^*$. But by definition, $\Lambda_{j-\rho(k+1)}^* = \Lambda_{j-\rho(k+1)}^\otimes - \tilde{\epsilon}$, where $\tilde{\epsilon} = 0, 1$. The use of Lemma 3.1.2 then leads to $\rho(r-1) \geq \delta + \rho r - \tilde{\epsilon}$. Hence $\delta = 0$, $\tilde{\epsilon} = 1$, and $\rho = 1$. In short, we have shown that

$$\begin{aligned} \Gamma_j^* &= \Lambda_{j-k-1}^* - r + 1, & \Gamma_j^\otimes &= \Lambda_{j-k-1}^\otimes - r + 1, & \Gamma_{j-1}^* &= \Lambda_{j-1}^*, \\ \Gamma_{j-1}^\otimes &= \Lambda_{j-1}^\otimes, & \Lambda_{j-k-1}^\otimes &= \Lambda_{j-k-1}^* + 1. \end{aligned}$$

Now, if Λ is strict and weakly $(k, r; N)$ -admissible, then $\Gamma_j^\otimes = \Gamma_j^* + 1$ implies $\Gamma_{j-1}^* = \Lambda_{j-1}^* \geq \Gamma_j^\otimes$. Combining the previous equations, we get $\Lambda_{j-1}^* \geq \Lambda_{j-k-1}^\otimes - r + 1$, which contradicts the weak admissibility condition.

On the other hand, if Λ is strongly $(k, r; N)$ -admissible, then $\Gamma_{j-1}^\otimes = \Lambda_{j-1}^\otimes \geq \Gamma_j^\otimes$ implies $\Lambda_{j-1}^\otimes \geq \Lambda_{j-k-1}^\otimes - r + 1$, which contradicts the strong admissibility condition.

Therefore, whenever Λ is (k, r, N) -admissible, we cannot find a superpartition $\Gamma < \Lambda$ such that $\varepsilon_{\Gamma^*}(\alpha, u) = \varepsilon_{\Lambda^*}(\alpha, u)$ and $\varepsilon_{\Gamma^\otimes}(\alpha, u) = \varepsilon_{\Lambda^\otimes}(\alpha, u)$.

□

3.5 UNIQUENESS FOR NON-SYMMETRIC JACK POLYNOMIALS

Motivated by the uniqueness result of the Jack polynomials with prescribed symmetry, we have tried to get a similar result for non-symmetric Jack polynomials. However, we only have obtained a characterization for non-symmetric Jack polynomials indexed for compositions of the type (3.2.1) and such that if Λ is its associated superpartition, then Λ is $(1, r, N)$ -admissible. Moreover, we have had to set a difference between the type of admissibility of the associated superpartition and the special form of the composition.

Definition 3.5.1. Let $\lambda = (\lambda_1, \dots, \lambda_N)$ be a composition and let $\Lambda = \varphi_m(\lambda)$ be its associated superpartition. We say that λ is weakly, moderately, or strongly $(k, r, N|m)$ -admissible if and only if Λ is weakly, moderately, or strongly (k, r, N) -admissible respectively.

Theorem 3.5.2 (Uniqueness for $k = 1$: weak admissibility). *Let*

$\lambda = (\eta_1, \dots, \eta_m, \mu_1, \dots, \mu_{N-m})$ be a composition formed by the concatenation of the partitions $\eta = (\eta_1, \dots, \eta_m)$ and $\mu = (\mu_1, \dots, \mu_{N-m})$. Assume that λ is weakly $(1, r, N|m)$ -admissible and η is strictly decreasing. Assume moreover that $\alpha = \alpha_{1,r}$. Then, the non-symmetric Jack polynomial E_λ is the unique polynomial satisfying:

1. $E_\lambda = x^\lambda + \sum_{\gamma \prec \lambda} c_{\lambda,\gamma} x^\gamma, \quad c_{\lambda,\gamma} \in \mathbb{C},$
2. $\xi_i E_\lambda = \bar{\lambda}_i E_\lambda \quad \forall 1 \leq i \leq N,$

where the $\bar{\lambda}_i$'s denote the eigenvalues introduced in (A2') and (2.3.2).

Proof. There are more than one polynomials satisfying (1) and (2) only if there are compositions γ such that $\gamma \prec \lambda$ and $(\bar{\gamma}_1, \dots, \bar{\gamma}_N) = (\bar{\lambda}_1, \dots, \bar{\lambda}_N)$. We can thus establish the uniqueness by showing show that the latter equality is impossible. Our task will be simplified by working with the associated superpartitions

$$\Lambda = \varphi_m(\lambda), \quad \Gamma = \varphi_m(\gamma).$$

We indeed know that $\Gamma < \Lambda$ whenever $\gamma \prec \lambda$. Moreover, according to Lemma 2.3.3, the equality $(\bar{\gamma}_1, \dots, \bar{\gamma}_N) = (\bar{\lambda}_1, \dots, \bar{\lambda}_N)$ holds only if $\varepsilon_{\Gamma^*}(\alpha, u) = \varepsilon_{\Lambda^*}(\alpha, u)$, and $\varepsilon_{\Gamma^\otimes}(\alpha, u) = \varepsilon_{\Lambda^\otimes}(\alpha, u)$.

Let us now assume that we are given a superpartition Γ such that $\varepsilon_{\Gamma^*}(\alpha, u) = \varepsilon_{\Lambda^*}(\alpha, u)$ and $\varepsilon_{\Gamma^\otimes}(\alpha, u) = \varepsilon_{\Lambda^\otimes}(\alpha, u)$. The last two equalities hold if and only if there are permutations σ and ω such that

$$\Gamma_i^* = \Lambda_{\sigma(i)}^* + \frac{r-1}{2}(\sigma(i) - i), \quad \Gamma_i^\otimes = \Lambda_{\omega(i)}^\otimes + \frac{r-1}{2}(\omega(i) - i) \quad \forall i. \quad (3.5.1)$$

We recall that by hypothesis, Λ is strict and $(1, r, N)$ -admissible and $\Gamma < \Lambda$, which means that either $\Gamma^* < \Lambda^*$ or $\Gamma^* = \Lambda^*$ and $\Gamma^\otimes < \Lambda^\otimes$.

The simplest case is when $\Gamma^* = \Lambda^*$ and $\Gamma^\circledast < \Lambda^\circledast$. Indeed, $\Gamma_i^* = \Lambda_i^*$ for all i implies $\sigma = \text{id}$, while Lemma 3.4.3 yields $\sigma = \omega$, so that $\omega = \text{id}$ and $\Gamma^\circledast = \Lambda^\circledast$. This contradicts the assumption $\Lambda \neq \Gamma$. Thus, the equations $\Gamma^* = \Lambda^*$, $\Gamma^\circledast < \Lambda^\circledast$, $\varepsilon_{\Gamma^*}(\alpha, u) = \varepsilon_{\Lambda^*}(\alpha, u)$, and $\varepsilon_{\Gamma^\circledast}(\alpha, u) = \varepsilon_{\Lambda^\circledast}(\alpha, u)$ cannot be satisfied simultaneously if Λ is strict and $(1, r, N)$ -admissible.

We now assume that $\Gamma^* < \Lambda^*$. This condition implies that there exists an integer $j > 1$ such that

$$\Gamma_j^* > \Lambda_j^* \quad \text{and} \quad \Gamma_i^* \leq \Lambda_i^*, \quad \forall i < j.$$

According to Lemma 3.4.1, satisfying the first equality in (3.5.1) is possible only if $\sigma(j) = j - 2$. Thus

$$\Gamma_j^* = \Lambda_{j-2}^* - r + 1$$

Now, $\Lambda_{j-2}^\circledast = \Lambda_{j-2}^* + \epsilon$ for some $0 \leq \epsilon \leq 1$, and $\Gamma_j^* = \Lambda_{j-1}^* - \delta$ for some $\delta \geq 0$. Hence,

$$\epsilon + r = \Lambda_{j-2}^\circledast - \Lambda_{j-1}^* + \delta + 1,$$

which is compatible with the admissibility only if $\epsilon = 1$ and $\delta = 0$. Combining all the previous results, we get

$$(i) \quad \Gamma_j^* = \Lambda_{j-2}^* - r + 1 \quad (ii) \quad \Gamma_j^* = \Gamma_{j-1}^* = \Lambda_{j-1}^* \quad (iii) \quad \Lambda_{j-2}^\circledast = \Lambda_{j-2}^* + 1$$

By making use of Lemma 3.4.1 together with $\Lambda_{j-2}^* \geq \Gamma_{j-2}^*$ and (ii), we also conclude that either $\sigma(j-2) = j-2$ or $\sigma(j-2) = j$. The first case is obviously impossible since it contradicts $\sigma(j) = j-2$. The second case implies $\Gamma_{j-2}^* = \Lambda_j^* + r - 1$. Lemma 3.4.3 and (i) imply that $\Gamma_j^\circledast = \Lambda_{j-2}^\circledast - r + 1$. Then, combining this equation with (iii), we get

$$(iv) \quad \Gamma_j^\circledast = \Gamma_j^* + 1.$$

Moreover, Lemma 3.4.3 and (ii) imply that $\Gamma_{j-1}^\circledast = \Lambda_{j-1}^\circledast$. From this and result (iv), we get $\Gamma_{j-1}^\circledast = \Gamma_{j-1}^* + 1$, i.e. the row $j-1$ in Γ also contains a circle. Combining $\Gamma_{j-2}^* \geq \Gamma_{j-1}^*$, the admissibility condition and $\Gamma_{j-2}^* = \Lambda_j^* + r - 1$ we obtain $\Gamma_{j-2}^* = \Gamma_{j-1}^*$. Finally, Lemma 3.4.3 and the last equation yields $\Gamma_{j-2}^\circledast = \Gamma_{j-2}^* + 1$. Consequently,

$$(v) \quad \Gamma_{j-2}^* = \Gamma_{j-1}^* = \Gamma_j^* \quad (vi) \quad \Lambda_{j-2}^* = \Lambda_{j-1}^* + r - 1 = \Lambda_j^* + 2(r-1).$$

Let us recapitulate what we have obtained so far. We have shown that there exist compositions λ and γ as in the statement of the theorem such that their associated superpartitions $\Lambda = \varphi_m(\lambda)$ and $\Gamma = \varphi_m(\gamma)$ satisfy $\varepsilon_{\Gamma^*}(\alpha, u) = \varepsilon_{\Lambda^*}(\alpha, u)$ and $\varepsilon_{\Gamma^\otimes}(\alpha, u) = \varepsilon_{\Lambda^\otimes}(\alpha, u)$. However, this occurs only if the equations (i) to (vi) are also satisfied. We will now make use of this information to prove that the equality $(\bar{\gamma}_1, \dots, \bar{\gamma}_N) = (\bar{\lambda}_1, \dots, \bar{\lambda}_N)$ is incompatible with the admissibility of λ .

Before doing so, we need to recall how relate the eigenvalues $\bar{\lambda}_i$ and $\bar{\gamma}_i$ to the elements of the superpartitions Λ and Γ . Let w_γ be the smallest permutation such that $\gamma = w_\gamma(\gamma^+) = w_\gamma(\Gamma^*)$. Then, $\bar{\gamma}_i$ is equal to the i th element of the composition $(\alpha\gamma - w_\gamma\delta^-)$. More explicitly, $\bar{\gamma}_i = (w_\gamma(\alpha\Gamma^* - \delta^-))_i$ or equivalently, $\bar{\gamma}_{w_\gamma(i)} = \alpha\Gamma_i^* - (i - 1)$. Similarly, there is a minimal permutation w_λ such that $\lambda = w_\lambda(\Lambda^*)$, so that $\bar{\lambda}_{w_\lambda(i)} = \alpha\Lambda_i^* - (i - 1)$. We stress that in our case $\Lambda^* \neq \Gamma^*$, which implies that $w_\lambda \neq w_\gamma$.

Now, let j be the largest integer such that $\Gamma_j^* > \Lambda_j^*$ and $\Gamma_{j-1}^* \leq \Lambda_{j-1}^*$. Let also $l = w_\gamma(j)$. Then, according to the above discussion,

$$\bar{\gamma}_l = \alpha\Gamma_j^* - (j + 1).$$

From (i) and (vi) above, we deduce that the last equation can be rewritten as

$$\bar{\gamma}_l = \alpha(\Lambda_j^* + r - 1) - (j - 1). \quad (3.5.2)$$

Moreover, let j' be defined as $w_\lambda^{-1}(l)$. This implies that

$$\bar{\lambda}_l = \alpha\Lambda_{j'}^* - (j' - 1). \quad (3.5.3)$$

Combining equations (3.5.2) and (3.5.3), we get

$$\bar{\lambda}_l - \bar{\gamma}_l = \alpha(\Lambda_{j'}^* - \Lambda_j^* - r + 1) + j - j'. \quad (3.5.4)$$

We are going to use the last equation and prove $\bar{\lambda}_l - \bar{\gamma}_l \neq 0$. Three cases must be analyzed separately:

- (1) $\lambda_l = \Lambda_j^*$. Then, $\bar{\lambda}_l - \bar{\gamma}_l = -\alpha(r - 1)$, which is clearly different from 0.
- (2) $\lambda_l < \Lambda_j^*$. Then, $\Lambda_{j'}^* < \Lambda_j^*$ and $j' > j$. By the admissibility condition, we have $\Lambda_j^* - \Lambda_{j'}^* \geq \rho(r - 1)$, where $\rho = j' - j$. Thereby, $\Lambda_j^* - \Lambda_{j'}^* = \rho(r - 1) + \delta$ for some $\delta \geq 0$. Now,

$$\bar{\lambda}_l - \bar{\gamma}_l = -\alpha((\rho + 1)(r - 1) + \delta) - \rho.$$

Substituting $\alpha = \alpha_{1,r} = -2/(r-1)$ into the last equation, we see that it is equal to zero if and only if $2((\rho+1)(r-1) + \delta) = \rho(r-1)$. This is impossible.

- (3) $\lambda_l > \Lambda_j^*$. Then, $\Lambda_{j'}^* > \Lambda_j^*$ and $j' < j$. Let $\rho = j - j'$. The admissibility condition implies that $\Lambda_{j'}^* - \Lambda_j^* \geq \rho(r-1)$. Thereby, $\Lambda_{j'}^* - \Lambda_j^* = \rho(r-1) + \bar{\delta}$ for some $\bar{\delta} \geq 0$. Thus,

$$\bar{\lambda}_l - \bar{\gamma}_l = \alpha((\rho-1)(r-1) + \bar{\delta}) + \rho.$$

The last equation is zero when $\alpha = \alpha_{1,r} = -2/(r-1)$ if and only if $2((\rho-1)(r-1) + \bar{\delta}) = \rho(r-1)$, which is equivalent to $(\rho-2)(r-1) + 2\bar{\delta} = 0$. It is clear that if $\rho > 2$, we have $\bar{\lambda}_l \neq \bar{\gamma}_l$. Therefore we have only to analyze the cases for which $\rho = 1$ and $\rho = 2$.

On the one hand, if $\rho = 1$, then $j' = j - 1$ and $\Lambda_{j'}^* = \Lambda_{j-1}^*$. Substituting the last equality and (vi) into (3.5.4), we get $\bar{\lambda}_l - \bar{\gamma}_l = 1$.

On other hand, if $\rho = 2$, then $j' = j - 2$ and $\Lambda_{j'}^* = \Lambda_{j-2}^*$. Using once again (vi) and (3.5.4), we find

$$\bar{\lambda}_l - \bar{\gamma}_l = \alpha(r-1) + 2.$$

Replacing α by $\alpha_{1,r} = -\frac{2}{r-1}$ into the last equation, we get $\bar{\lambda}_l - \bar{\gamma}_l = 0$. Thus, we have not reached the desired conclusion yet. However, given that in the present case, we have $\lambda_{l-1} > \lambda_l = \Lambda_{j-2}^*$ and $\gamma_{l-1} = \gamma_l = \Gamma_j^* = \Gamma_{j-1}^* = \Gamma_{j-2}^*$, we know that $w_{\bar{\lambda}}^{-1}(l-1) = \bar{j} < j-2$, so that $\Lambda_{\bar{j}}^* > \Lambda_{j-2}^*$. Let $\bar{\rho} := j-2-\bar{j}$. The admissibility condition then gives $\Lambda_{\bar{j}}^* - \Lambda_{j-2}^* \geq \bar{\rho}(r-1)$, which is equivalent to $\Lambda_{\bar{j}}^* = \Lambda_{j-2}^* + \bar{\rho}(r-1) + \epsilon$ for some $\epsilon \geq 0$. Then

$$\begin{aligned} \bar{\lambda}_{l-1} - \bar{\gamma}_{l-1} &= \alpha(\Lambda_{j-2}^* + \bar{\rho}(r-1) + \epsilon) - (\bar{j}-1) - \alpha\Gamma_{j-1}^* + (j-2) \\ &= \alpha(\Lambda_{j-2}^* + \bar{\rho}(r-1) + \epsilon) - \alpha(\Lambda_{j-2}^* - (r-1)) + \bar{\rho} + 1 \\ &= \alpha((\bar{\rho}+1)(r-1) + \epsilon) + \bar{\rho} + 1 \end{aligned}$$

Finally, the substitution of $\alpha = \alpha_{1,r} = -2/(r-1)$ into the last equation implies that $\bar{\lambda}_{l-1} = \bar{\gamma}_{l-1}$ iff $2(\bar{\rho}+1)(r-1) + 2\epsilon = (\bar{\rho}+1)(r-1)$, which is impossible.

We have thus shown that there could exist compositions, λ and γ , such that Λ is $(1, r, N)$ -admissible, $\Gamma^* < \Lambda^*$ and $\varepsilon_{\Gamma^*}(\alpha, u) = \varepsilon_{\Lambda^*}(\alpha, u)$. However, when it happens, we also have $(\bar{\lambda}_1, \dots, \bar{\lambda}_N) \neq (\bar{\gamma}_1, \dots, \bar{\gamma}_N)$ and the theorem follows. \square

Looking at the proof of the previous Theorem "Uniqueness for $k = 1$ " for the case of weak admissibility, we remark that it is not enough to consider the associated superpartition to the composition. In fact, by fixing $k = 1$, $r = 2$ and $N = 3$, we see that $\Lambda = (2, 1, 0; \emptyset)$ is weakly $(1, 2, 3)$ -admissible and moreover by considering $\Gamma = (1, 1, 1; \emptyset)$, we can check that Γ satisfies the conditions given in the preceding proof: $\Gamma^* < \Lambda^*$, $\varepsilon_{\Gamma^*}(-2, u) = \varepsilon_{\Lambda^*}(-2, u)$ and $\varepsilon_{\Gamma^\circ}(-2, u) = \varepsilon_{\Lambda^\circ}(-2, u)$. Indeed:

$$\begin{aligned} \varepsilon_{\Lambda^*}(-2, u) &= (u-4)(u-3)(u-2) & \text{and} & & \varepsilon_{\Lambda^\circ}(-2, u) &= (u-6)(u-5)(u-4) \\ \varepsilon_{\Gamma^*}(-2, u) &= (u-2)(u-3)(u-4) & \text{and} & & \varepsilon_{\Gamma^\circ}(-2, u) &= (u-4)(u-5)(u-6). \end{aligned}$$

We can check also that the eigenvalues associated to $E_{(2,1,0)}(x; -2)$ and $E_{(1,1,1)}(x; -2)$ are the same as sets, but if they are considered as tuples, then they are different.

Let us remark that the preceding comment was the main difficult in the proof of the Theorem. However, for the moderate admissibility case, the proof is easier than the weak admissibility case, due to the conditions imposed over the components of the compositions by the admissibility condition.

Theorem 3.5.3 (Uniqueness for $k = 1$: moderate admissibility). *Let*

$\lambda = (\eta_1, \dots, \eta_m, \mu_1, \dots, \mu_{N-m})$ *be a composition formed by the concatenation of the partitions* $\eta = (\eta_1, \dots, \eta_m)$ *and* $\mu = (\mu_1, \dots, \mu_{N-m})$. *Assume that* λ *is moderately* $(1, r, N|m)$ -*admissible. Assume moreover that* $\alpha = \alpha_{1,r}$. *Then, the non-symmetric Jack polynomial* E_λ *is the unique polynomial satisfying:*

1. $E_\lambda = x^\lambda + \sum_{\gamma < \lambda} c_{\lambda, \gamma} x^\gamma, \quad c_{\lambda, \gamma} \in \mathbb{C},$
2. $\xi_i E_\lambda = \bar{\lambda}_i E_\lambda \quad \forall 1 \leq i \leq N,$

where the $\bar{\lambda}_i$'s denote the eigenvalues introduced in (A2') and (2.3.2).

Proof. We proceed as in Theorem 3.5.2. We start by introducing the associated superpartitions $\Lambda = \varphi_m(\lambda)$ and $\Gamma = \varphi_m(\gamma)$. We then assume that we are given

a superpartition Γ such that $\varepsilon_{\Gamma^*}(\alpha, u) = \varepsilon_{\Lambda^*}(\alpha, u)$ and $\varepsilon_{\Gamma^\circledast}(\alpha, u) = \varepsilon_{\Lambda^\circledast}(\alpha, u)$, which is possible if and only if equation (3.5.1) is satisfied for some $\sigma, \omega \in S_N$. We recall that by hypothesis, Λ is moderately $(1, r, N)$ -admissible and $\Gamma < \Lambda$, which means that either $\Gamma^* < \Lambda^*$ or $\Gamma^* = \Lambda^*$ and $\Gamma^\circledast < \Lambda^\circledast$.

First, we assume that $\Gamma^* = \Lambda^*$ and $\Gamma^\circledast < \Lambda^\circledast$. This obviously implies that $\Gamma_i^* = \Lambda_i^*$ for all i , but also that there exists an integer $j > 1$ such that

$$\Gamma_j^* = \Lambda_j^* = \Lambda_j^\circledast, \quad \Gamma_j^\circledast = \Lambda_j^\circledast + 1 \quad \text{and} \quad \Gamma_i^\circledast = \Lambda_i^\circledast - \delta_i, \quad \delta_i = 0, 1 \quad \forall i < j.$$

By making use of Lemma 3.4.2, $\Lambda_j^\circledast < \Gamma_j^\circledast$ and $\Gamma_{j-1}^* = \Lambda_{j-1}^*$, we conclude that $\omega(j) = j - 2$. This implies $\Gamma_j^\circledast = \Lambda_{j-2}^\circledast - r + 1$ and $\Gamma_j^\circledast = \Lambda_j^\circledast + 1$, so we get $\Lambda_{j-2}^\circledast - \Lambda_j^\circledast = r$, which is in contradiction with the admissibility.

Second, we assume that $\Gamma^* < \Lambda^*$, which implies that there exists a $j > 1$ such that

$$\Gamma_j^* > \Lambda_j^* \quad \text{and} \quad \Gamma_i^* \leq \Lambda_i^*, \quad \forall i < j.$$

According to Lemma 3.4.1, the first equality in (3.5.1) is possible when $i = j$ only if $\sigma(j) = j - 2$. Thus

$$\Gamma_j^* = \Lambda_{j-2}^* - r + 1$$

Now $\Lambda_{j-2}^\circledast = \Lambda_{j-2}^* + \epsilon$ for some $0 \leq \epsilon \leq 1$, and $\Gamma_j^* = \Lambda_{j-1}^* - \delta$ for some $\delta \geq 0$. Hence,

$$\epsilon + r = \Lambda_{j-2}^\circledast - \Lambda_{j-1}^* + \delta + 1,$$

which is compatible with the admissibility only if $\epsilon = 1$ and $\delta = 0$. Combining all the previous results, we get

$$\begin{aligned} (i) \quad \Gamma_j^* &= \Lambda_{j-2}^* - r + 1 & (ii) \quad \Gamma_j^* &= \Gamma_{j-1}^* = \Lambda_{j-1}^* \\ (iii) \quad \Lambda_{j-2}^\circledast &= \Lambda_{j-2}^* + 1 & (iv) \quad \Lambda_{j-1}^\circledast &= \Lambda_{j-1}^*. \end{aligned}$$

We now turn our attention to second equality in (3.5.1) when $i = j$. By assumption we know that $\Gamma_j^* > \Lambda_j^*$, so that $\Gamma_j^\circledast \geq \Lambda_j^\circledast$. By making use of Lemma 3.4.2, we get the following two options:

1. If $\Gamma_j^\circledast = \Lambda_j^\circledast$, then $\omega(j) = j$. However by assumption $\Gamma_j^* = \Lambda_j^* + \epsilon$ which implies $\Gamma_j^\circledast = \Lambda_j^\circledast = \Lambda_j^* + 1$ and $\Gamma_j^* = \Lambda_j^* + 1$, and then $\Gamma_j^\circledast = \Gamma_j^*$. Now, as $\Gamma_j^* = \Lambda_{j-2}^* - r$ we get $\Lambda_{j-2}^\circledast - r = \Lambda_j^\circledast$, which is clearly a contradiction with the admissibility.

2. If $\Gamma_j^\circledast > \Lambda_j^\circledast$, then $\omega(j) < j$. Now, from $\Gamma_j^\circledast > \Lambda_j^\circledast$ and (ii), we know using Lemma 3.4.2, that $\omega(j) = j - 2$, i.e. $\Gamma_j^\circledast = \Lambda_{j-2}^\circledast - r + 1$. Thus, the row j in Γ contains a circle. This in turn implies that $\Gamma_{j-1}^\circledast = \Gamma_{j-1}^* + 1$, and also that the row $j - 1$ in Γ contains a circle.

So far, considering the row j , we have obtained

$$(v) \quad \Gamma_j^\circledast = \Gamma_j^* + 1 \quad (vi) \quad \Gamma_{j-1}^\circledast = \Gamma_{j-1}^* + 1.$$

Now, considering (ii), (iv) and (vi), we obtain $\Gamma_{j-1}^\circledast > \Lambda_{j-1}^\circledast$. Moreover, from $\Gamma_{j-2}^* \leq \Lambda_{j-2}^*$ and Lemma 3.4.2, we get $\omega(j-1) = j - 3$ and $\Gamma_{j-1}^\circledast = \Lambda_{j-3}^\circledast - r + 1$. However, (ii), (iv), and (vi) imply that $\Gamma_{j-1}^\circledast = \Lambda_{j-1}^\circledast + 1$. Combining these equations, we conclude that $\Lambda_{j-3}^\circledast - \Lambda_{j-1}^\circledast = r$. This violates our assumptions, because the moderate admissibility condition implies that $\Lambda_{j-3}^\circledast - \Lambda_{j-1}^\circledast \geq 2r$.

We have shown that whenever $\Lambda > \Gamma$ and Λ is moderately $(1, r, N)$ -admissible, then $(\bar{\lambda}_1, \dots, \bar{\lambda}_N) \neq (\bar{\gamma}_1, \dots, \bar{\gamma}_N)$, and the proof is complete. \square

CHAPTER 4

CLUSTERING PROPERTIES

In this chapter we study the clustering properties of Jack polynomials with prescribed symmetry. To this end, we consider two cases individually: $k = 1$ and $k > 1$. In the first case, we get for each family of Jack polynomials with prescribed symmetry a factorization, where the expected degree is reached. For $k > 1$, we establish the clustering properties by following a strategy developed by Baratta and Forrester in reference [8], according to which if a symmetric polynomial is translationally invariant then it almost automatically admits clusters. We first generalize results of Luque and Jolicoeur about translationally invariant Jack polynomials [37] by finding the necessary and sufficient conditions that make the Jack polynomials with prescribed symmetry are invariant under translation. We then generalize the above-mentioned result of Baratta and Forrester and get clustering properties for Jack polynomials with prescribed symmetry of type AS and translation invariance. Most of the results contained in this chapter have been published for the first time in [20, Section 4].

4.1 DEFINITION CLUSTERING PROPERTY

To start this chapter we remind the definition of the clustering property.

Given $f(x_1, x_2, \dots, x_N)$ a symmetric polynomial in N variables, we say that f admits a clustering of size k and order r if:

- $f(\overbrace{z, \dots, z}^k, x_{k+1}, \dots, x_N) \neq 0$
- $f(\overbrace{z, \dots, z}^{k+1}, x_{k+2}, \dots, x_N) = 0$

and moreover f vanishes with order r when $k + 1$ variables are identified; i.e.

$$f(\overbrace{z, \dots, z}^k, x_{k+1}, \dots, x_N) \propto \prod_{i=k+1}^N (z - x_i)^r.$$

For instance,

$$\begin{aligned} f(x_1, x_2, x_3) = & -4x_2^2x_3^2 + x_2^3x_3 + x_2x_3^3 - 4x_2^2x_1^2 - 4x_1^2x_3^2 + x_1^3x_2 + x_1^3x_3 + x_1x_2^3 \\ & + x_1x_3^3 + 2x_1^2x_2x_3 + 2x_1x_2^2x_3 + 2x_1x_2x_3^2 \end{aligned}$$

is a symmetric polynomial in three variables. Now, w.l.g if we specialize the last two variables, we get $2z(x_1 - z)^3$, and it is clear that f vanishes with order 3 when 3 variables are identified, and therefore we can say that f admits a clustering of size 2 and order 3.

4.2 CLUSTERING PROPERTIES FOR $k = 1$

We start this section by generalizing the clustering property given in [8, Proposition 2]. This property shows the explicit factorization of the non-symmetric Jack polynomials indexed by $(1, r, N)$ -admissible partitions at the specialization $\alpha = -2/(r - 1)$ (with r even). We generalize this result by considering non-symmetric Jack polynomials indexed by particular compositions formed by the concatenation of two partitions and such that the associated superpartitions to the compositions are $(1, r, N)$ -admissible. We then use these results and prove clustering properties for each family of Jack polynomials with prescribed symmetry.

Before stating our results we must find a way to add a superpartition with a partition, which will first be specified formally in the following definition and then will be illustrated in terms of diagrams.

Definition 4.2.1. *Let Λ be a superpartition and let λ be a partition. We formally define the superpartition $\Lambda + \lambda = (\Omega^*, \Omega^\circledast)$ where $\Omega^* = \Lambda^* + \lambda$ and $\Omega^\circledast = \Lambda^\circledast + \lambda$. In terms of the diagrams, it is interpreted as the associated superpartition to the diagram obtained by adding the diagrams of Λ and λ .*

Let us illustrate this definition by computing $\Lambda + \lambda$ when $\Lambda = (5, 3, 1, 0; 4, 2, 1)$ and $\lambda = (6, 5, 4, 3, 2, 1, 0)$. Obviously, we have

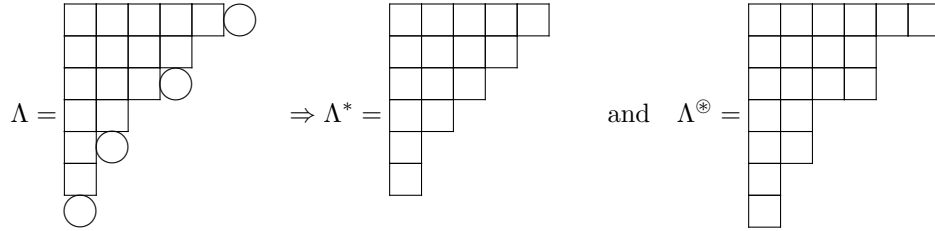

Then,

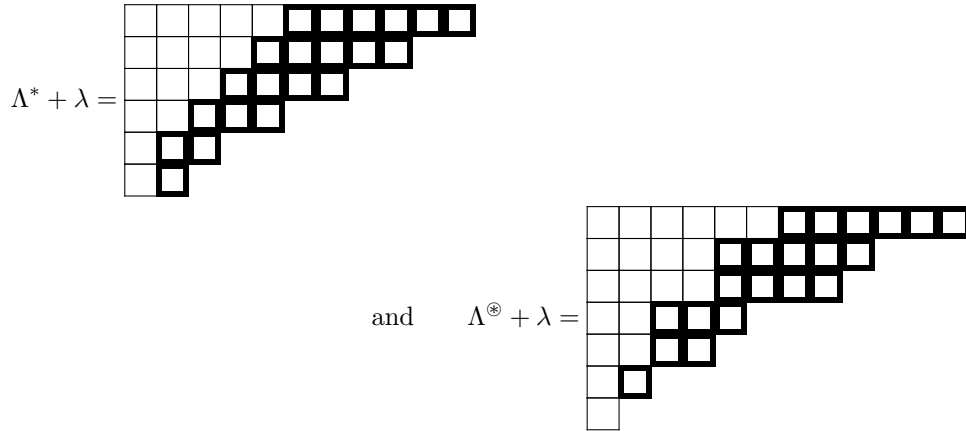

Thus, the diagram obtained by adding the diagrams associated to Λ and λ is given by

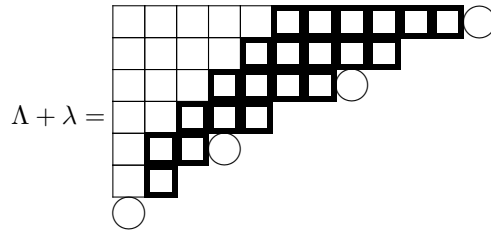

which is equivalent to say that $\Lambda + \lambda = (11, 7, 3, 0; 9, 5, 2)$.

Proposition 4.2.2. *Let r be even and positive. Let also $\kappa = (\lambda^+, \mu^+)$, where λ^+ is a partition with m parts while μ^+ is a strictly decreasing partition with $N - m$ parts. Then*

$$E_{\kappa+(r-1)\delta'}(x_1, \dots, x_N; -2/(r-1)) \propto \prod_{1 \leq i < j \leq N} (x_i - x_j)^{r-1} E_{\kappa}(x_1, \dots, x_N; 2/(r-1)).$$

In the above equation, $\delta' = \omega_{\kappa}(\delta)$, where $\delta = (N - 1, N - 2, \dots, 1, 0)$ and ω_{κ} is the smallest permutation such that $\kappa = \omega_{\kappa}(\kappa^+)$.

Proof. In what follows, we set $\Lambda = \varphi_m(\kappa)$ and use the shorthand notation

$$\Delta_N = \prod_{1 \leq i < j \leq N} (x_i - x_j).$$

First, we consider the action of ξ_j on the polynomial $\Delta_N^{(r-1)} E_\kappa(x; 2/(r-1))$:

$$\begin{aligned} \xi_j(\Delta_N^{(r-1)} E_\kappa(x; 2/(r-1))) &= \alpha(r-1) \Delta_N^{(r-1)} \sum_{i=1, i \neq j}^N \frac{x_j}{x_j - x_i} E_\kappa(x; 2/(r-1)) \\ &+ \alpha \Delta_N^{(r-1)} x_j \partial_{x_j} E_\kappa(x; 2/(r-1)) + \Delta_N^{(r-1)} \sum_{i < j} \frac{x_j}{x_j - x_i} (1 + K_{ij}) E_\kappa(x; 2/(r-1)) \\ &+ \Delta_N^{(r-1)} \sum_{i > j} \frac{x_i}{x_j - x_i} (1 + K_{ij}) E_\kappa(x; 2/(r-1)) - (j-1) \Delta_N^{(r-1)} E_\kappa(x; 2/(r-1)). \end{aligned}$$

Second, we restrict ξ_j by imposing $\alpha = -2/(r-1)$, which gives

$$\begin{aligned} \xi_j|_{\alpha=-2/(r-1)}(\Delta_N^{(r-1)} E_\kappa(x; 2/(r-1))) &= -\frac{2}{r-1} \Delta_N^{(r-1)} x_j \partial_{x_j} E_\kappa(x; 2/(r-1)) \\ &- \Delta_N^{(r-1)} \sum_{i=1, i \neq j}^N \frac{x_j}{x_j - x_i} (1 - K_{ij}) E_\kappa(x; 2/(r-1)) - \Delta_N^{(r-1)} \sum_{i > j} K_{ij} E_\kappa(x; 2/(r-1)) \\ &- (N-1) \Delta_N^{(r-1)} E_\kappa(x; 2/(r-1)). \end{aligned}$$

By reordering the terms, we also get

$$\begin{aligned} \xi_j|_{\alpha=-2/(r-1)}(\Delta_N^{(r-1)} E_\kappa(x; 2/(r-1))) \\ = -\Delta_N^{(r-1)} (\xi_j|_{\alpha=2/(r-1)} + 2(N-1)) E_\kappa(x; 2/(r-1)). \end{aligned}$$

Now, the use of (A2'), allows us to write

$$\begin{aligned} \xi_j|_{\alpha=-2/(r-1)}(\Delta_N^{(r-1)} E_\kappa(x; 2/(r-1))) \\ = -(\bar{\kappa}_j|_{\alpha=2/(r-1)} + 2(N-1)) \Delta_N^{(r-1)} E_\kappa(x; 2/(r-1)). \quad (4.2.1) \end{aligned}$$

We have proved that $(\Delta_N^{(r-1)} E_\kappa(x; 2/(r-1)))$ is an eigenfunction of $\xi_j|_{\alpha=-2/(r-1)}$ for each j . The eigenvalue can be reorganized as follows. On the one hand, we know from equation (2.3.2) that the eigenvalues associated to $E_\kappa(x; 2/(r-1))$ restricted to $\alpha = 2/(r-1)$ are given by

$$\bar{\kappa}_j|_{\alpha=2/(r-1)} = \frac{2}{r-1} \kappa_j - \#\{i < j | \kappa_i \geq \kappa_j\} - \#\{i > j | \kappa_i > \kappa_j\}.$$

Now, given κ_j in κ , we know that to κ_j corresponds a cell in diagram of κ and moreover, this cell has an associated cell s in diagram of Λ . Then, we can express

the eigenvalues $\bar{\kappa}_j$ in terms of arm-colength and leg-colength of cell s in Λ . Given that

$$a'_{\Lambda^*}(s) = \kappa_j - 1 \quad \text{and} \quad l'_{\Lambda^*}(s) = \#\{i < j | \kappa_i \geq \kappa_j\} + \#\{i > j | \kappa_i > \kappa_j\},$$

we can rewrite the eigenvalue as

$$\bar{\kappa}_j|_{\alpha=2/(r-1)} = \frac{2}{r-1}(a'_{\Lambda^*}(s) + 1) - l'_{\Lambda^*}(s). \quad (4.2.2)$$

On the other hand, from equation (2.3.2) and considering the composition $\kappa + (r-1)\delta'$, we have

$$\begin{aligned} \overline{(\kappa + (r-1)\delta')}_j &= \alpha(\kappa_j + (r-1)\delta'_j) - \#\{i < j | \kappa_i + (r-1)\delta'_i \geq \kappa_j + (r-1)\delta'_j\} \\ &\quad - \#\{i > j | \kappa_i + (r-1)\delta'_i > \kappa_j + (r-1)\delta'_j\}. \end{aligned}$$

However, we can simplify this expression if we rewrite the eigenvalue in terms of $\Lambda' := \Lambda + (r-1)\delta$ the associated superpartition to $\kappa + (r-1)\delta'$. The same way as before, given $(\kappa + (r-1)\delta')_j$ in the composition $\kappa + (r-1)\delta'$, we know that to $(\kappa + (r-1)\delta')_j$ corresponds a cell in diagram of $\kappa + (r-1)\delta'$ and moreover, this cell has a cell s' associated in diagram of Λ' . So, we have

$$\begin{aligned} a'_{\Lambda'^*}(s') &= \kappa_j - 1 + (r-1)\delta'_j \\ l'_{\Lambda'^*}(s') &= \#\{i < j | \kappa_i + (r-1)\delta'_i \geq \kappa_j + (r-1)\delta'_j\} \\ &\quad + \#\{i > j | \kappa_i + (r-1)\delta'_i > \kappa_j + (r-1)\delta'_j\} \end{aligned}$$

Hence,

$$\overline{(\kappa + (r-1)\delta')}_j|_{\alpha=-2/(r-1)} = -\frac{2}{(r-1)}(a'_{\Lambda'^*}(s') + 1) - l'_{\Lambda'^*}(s'). \quad (4.2.3)$$

Now, comparing the arm-colenght and leg-colenght of Λ and Λ' , we get

$$a'_{\Lambda'^*}(s') = a'_{\Lambda^*}(s) + N - l'_{\Lambda'^*}(s) - 1 \quad \text{and} \quad l'_{\Lambda'^*}(s') = l'_{\Lambda^*}(s) \quad (4.2.4)$$

Hence, by combining the equations (4.2.1), (4.2.2), (4.2.3) and (4.2.4), we conclude that

$$E_{\kappa+(r-1)\delta'}(x; -2/(r-1)) \quad \text{and} \quad \Delta_N^{r-1} E_\kappa(x; 2/(r-1))$$

have the same eigenvalues for each ξ_j with $j = 1, \dots, N$.

In brief, we have proved that $(\Delta_N^{(r-1)} E_\kappa(x; 2/(r-1)))$ as the same eigenvalues than $E_{\kappa+(r-1)\delta'}(x; -2/(r-1))$. Little work also shows that both polynomials exhibit triangular with dominant term $x^{\kappa+(r-1)\delta'}$. Moreover, because of the form of κ , the composition $\kappa + (r-1)\delta'$ is weakly $(1, r, N|m)$ -admissible. Therefore, we can make use of Theorem 3.5.2 and conclude that

$$E_{\kappa+(r-1)\delta'}(x_1, \dots, x_N; -2/(r-1)) \propto \prod_{1 \leq i < j \leq N} (x_i - x_j)^{r-1} E_\kappa(x_1, \dots, x_N; 2/(r-1)),$$

i.e., the polynomials are equal up to a multiplicative numerical factor. \square

Example 4.2.3. Given $r = 4$, $N = 3$ and $\kappa = (2, 2, 1)$, we have $\delta = (2, 1, 0)$, thus $\delta' = (2, 1, 0)$ and $\kappa + 3\delta' = (8, 5, 1)$. According to the last proposition we have the following factorization:

$$\begin{aligned} E_{(8,5,1)}(x_1, x_2, x_3; -2/3) &= \frac{1}{5} x_1 x_2 x_3 (x_1 - x_2)^3 (x_1 - x_3)^3 (x_2 - x_3)^3 \\ &\quad \times (5x_1 x_2 + 3x_1 x_3 + 3x_2 x_3) \\ &= (x_1 - x_2)^3 (x_1 - x_3)^3 (x_2 - x_3)^3 E_{(2,2,1)}(x_1, x_2, x_3; 2/3) \end{aligned}$$

and for $r = 2$, $N = 4$ and $\kappa = (2, 2, 3, 1)$, we have $\delta = (3, 2, 1, 0)$, thus $\delta' = (2, 1, 3, 0)$ and $\kappa + \delta' = (4, 3, 6, 1)$. So, using again Proposition 4.2.2, we have:

$$\begin{aligned} E_{(4,3,6,1)}(x_1, x_2, x_3, x_4; -2) &= \frac{1}{21} x_1 x_2 x_3 x_4 \prod_{1 \leq i < j \leq 4} (x_i - x_j) \\ &\quad \times (21x_1 x_2 x_3^2 + 8x_1 x_2 x_3 x_4 + 3x_1 x_2 x_4^2 + 7x_1 x_3^2 x_4 + x_1 x_3 x_4^2 + 7x_2 x_3^2 x_4 + x_2 x_3 x_4^2) \\ &= \prod_{1 \leq i < j \leq 4} (x_i - x_j) E_{(2,2,3,1)}(x_1, x_2, x_3, x_4; 2). \end{aligned}$$

We will present more examples in Appendix D.

Corollary 4.2.4. Let $r > 0$ even and let λ a partition with $\ell(\lambda) \leq N$. Then

$$E_{\lambda+(r-1)\delta_N}(x_1, \dots, x_N; -2/(r-1)) = \prod_{1 \leq i < j \leq N} (x_i - x_j)^{r-1} E_\lambda(x_1, \dots, x_N; 2/(r-1)).$$

Remark 4.2.5. *As mentioned above, the clustering property corresponding to Corollary 4.2.4 was first obtained in [8, Proposition 2]. The proof given in this reference uses the characterization of the non-symmetric Jack polynomials as the unique polynomials satisfying (A1') and (A2'). However, the problem of the validity of this characterization at $\alpha = \alpha_{k,r}$ was not addressed by the authors. Our result about the regularity and uniqueness given in Proposition 3.2.2 and Theorem 3.5.2 respectively, now firmly establishes the proof proposed in [8].*

Before stating the clustering properties for the polynomials with prescribed, we recall two useful formulas. For this, let

$$I = \{i_1, i_2, \dots, i_n\}, \quad J = \{j_1, j_2, \dots, j_m\},$$

$$\Delta_I = \prod_{\substack{i,j \in I \\ i < j}} (x_i - x_j), \quad \Delta_J = \prod_{\substack{i,j \in J \\ i < j}} (x_i - x_j).$$

Then, obviously,

$$\begin{aligned} \text{Sym}_I(\Delta_I f(x_1, \dots, x_N)) &= \Delta_I \text{Asym}_I(f(x_1, \dots, x_N)), \\ \text{Asym}_J(\Delta_J f(x_1, \dots, x_N)) &= \Delta_J \text{Sym}_J(f(x_1, \dots, x_N)). \end{aligned} \tag{4.2.5}$$

In the following proposition we study the general clustering property for $k = 1$ for each type of Jack polynomials with prescribed symmetry, getting the natural generalization of the clustering property for symmetric and antisymmetric Jack polynomials, which have been proved in [13] in the context of fractional quantum Hall states.

Proposition 4.2.6 (Clustering $k = 1$). *Let r be positive and even. Let also Λ be a superpartition of bi-degree $(n|m)$ with $\ell(\Lambda) \leq N$.*

(i) *If Λ is strict and weakly $(1, r, N)$ -admissible, then*

$$P_{\Lambda}^{\text{AS}}(x_1, \dots, x_N; -2/(r-1)) = \prod_{m+1 \leq i < j \leq N} (x_i - x_j)^r Q(x_1, \dots, x_N).$$

(ii) *If Λ is moderately $(1, r, N)$ -admissible, then*

$$\begin{aligned} P_{\Lambda}^{\text{SS}}(x_1, \dots, x_N; -2/(r-1)) \\ = \prod_{1 \leq i < j \leq m} (x_i - x_j)^r \prod_{m+1 \leq i < j \leq N} (x_i - x_j)^r Q(x_1, \dots, x_N). \end{aligned}$$

(iii) If Λ is moderately $(1, r, N)$ -admissible and it is such that $\Lambda_{m+1} > \dots > \Lambda_N$, then

$$P_{\Lambda}^{\text{SA}}(x_1, \dots, x_N; -2/(r-1)) = \prod_{1 \leq i < j \leq m} (x_i - x_j)^r Q(x_1, \dots, x_N).$$

(iv) If Λ is strict and weakly $(1, r, N)$ -admissible, and it is such that $\Lambda_{m+1} > \dots > \Lambda_N$, then

$$P_{\Lambda}^{\text{AA}}(x_1, \dots, x_N; -2/(r-1)) = \prod_{1 \leq i < j \leq N} (x_i - x_j)^{r-1} Q(x_1, \dots, x_N).$$

In the above equations, $Q(x_1, \dots, x_N)$ denotes some polynomial, which varies from one symmetry type to another.

Proof. Once again, all cases are similar, so we only provide the demonstration for the symmetry type AS, which corresponds to (i) above.

As before, we set $I = \{1, \dots, m\}$ and $J = \{m+1, \dots, N\}$. According to Definition 1.3 and Proposition 3.3.1, there is a composition η , obtained by the concatenation of two partitions, such that

$$P_{\Lambda}^{\text{AS}}(x_1, \dots, x_N; \alpha) \propto \text{Asym}_I \text{Sym}_J(E_{\eta}(x_1, \dots, x_N; \alpha)).$$

Given that Λ is $(1, r, N)$ -admissible, then η has the form $\kappa + (r-1)\delta'$ where $\kappa = (\lambda^+, \mu^+)$ is the composition obtained from η after subtraction of the composition $(r-1)\delta'$. Moreover, since Λ is strict and weakly $(1, r, N)$ -admissible, we know that κ is such that μ^+ is strictly decreasing. Thus,

$$P_{\Lambda}^{\text{AS}}(x_1, \dots, x_N; -2/(r-1)) \propto \text{Asym}_I \text{Sym}_J(E_{\kappa+(r-1)\delta'}(x_1, \dots, x_N; -2/(r-1))). \quad (4.2.6)$$

Now, by Proposition 4.2.2, we also have

$$E_{\kappa+(r-1)\delta'}(x_1, \dots, x_N; -2/(r-1)) \propto \prod_{1 \leq i < j \leq N} (x_i - x_j)^{r-1} E_{\kappa}(x_1, \dots, x_N; 2/(r-1)). \quad (4.2.7)$$

The substitution of (4.2.7) into (4.2.6), followed by the use of (4.2.5), leads to

$$P_{\Lambda}^{\text{AS}}(x_1, \dots, x_N; -2/(r-1)) \propto (\Delta_J)^{(r-1)} (\Delta_I)^{(r-1)} \text{Sym}_I \left(\prod_{i=1}^m \prod_{j=m+1}^N (x_i - x_j)^{(r-1)} \text{Asym}_J E_{\kappa}(x_1, \dots, x_N; 2/(r-1)) \right)$$

Now, we know that $\text{Asym}_J E_\kappa(x_1, \dots, x_N; 2/(r-1))$ is antisymmetric with respect to the set of variables indexed by J , so we can factorize the antisymmetric factor $\prod_{m+1 \leq i < j \leq N} (x_i - x_j)$. Exploiting once again (4.2.5), we finally obtain

$$P_\Lambda^{\text{AS}}(x_1, \dots, x_N; -2/(r-1)) \propto \prod_{m+1 \leq i < j \leq N} (x_i - x_j)^r Q(x_1, \dots, x_N),$$

where

$$Q(x_1, \dots, x_N) = \prod_{1 \leq i < j \leq m} (x_i - x_j)^{r-1} \prod_{i=1}^m \prod_{j=m+1}^N (x_i - x_j)^{(r-1)} \\ \times \text{Sym}_I \left(\frac{\text{Asym}_J E_\kappa(x_1, \dots, x_N; 2/(r-1))}{\prod_{m+1 \leq i < j \leq N} (x_i - x_j)} \right). \quad (4.2.8)$$

□

Remark 4.2.7. *The case (i) was first conjectured in [26] in the context of symmetric polynomials in superspace. All other cases are new.*

Corollary 4.2.8. *Let $\alpha = -\frac{2}{r-1}$ and let r be positive and even. Moreover, for any positive integer ρ , let*

$$\rho \delta_N = (\rho(N-1), \rho(N-2), \dots, \rho, 0).$$

Then, the antisymmetric Jack polynomial satisfies

$$S_{(r-1)\delta_N}(x_1, \dots, x_N; \alpha) = \prod_{1 \leq i < j \leq N} (x_i - x_j)^{(r-1)},$$

while the symmetric Jack polynomial satisfies

$$P_{r\delta_N}(x_1, \dots, x_N; \alpha) = \prod_{1 \leq i < j \leq N} (x_i - x_j)^r.$$

Proof. We recall that if $\ell(\lambda) = N$, then

$$S_\lambda(x; \alpha) = P_{(\lambda; \emptyset)}^{\text{AS}}(x; \alpha) \quad \text{and} \quad P_\lambda(x, \alpha) = P_{(\emptyset; \lambda)}^{\text{AS}}(x, \alpha).$$

The first result then follows from Proposition 4.2.6 and equation (4.2.8) for the case with $m = N$ and $\kappa = \emptyset$. The second result also follows from Proposition 4.2.6 and equation (4.2.8), but this time, with $m = 0$ and $\kappa = \delta_N$. □

Example 4.2.9. *In this example we show different clustering properties, by considering first a symmetric Jack polynomial, then second an antisymmetric Jack polynomial and finally a Jack polynomial with prescribed symmetry of type AS and other of type SS.*

- For $k = 1$, $r = 2$, $N = 3$ and $\lambda = (4, 2, 0)$, since that λ is weakly $(1, 2, 3)$ -admissible, we have

$$P_{(4,2,0)}(x_1, x_2, x_3; -2) = (x_1 - x_2)^2(x_1 - x_3)^2(x_2 - x_3)^2$$

- for $k = 1$, $r = 4$, $N = 3$ and $\lambda = (6, 3, 0)$, since that λ is weakly $(1, 4, 3)$ -admissible, we have

$$S_{(6,3,0)}(x_1, x_2, x_3; -2/3) = (x_1 - x_2)^3(x_1 - x_3)^3(x_2 - x_3)^3$$

- for $k = 1$, $r = 2$, $N = 3$ and $\Lambda = (0; 4, 2)$, since that Λ is weakly $(1, 2, 3)$ -admissible,

$$P_{(0;4,2)}^{\text{AS}}(x_1, x_2, x_3; -2) = x_2x_3(x_1 - x_2)(x_1 - x_3)(x_2 - x_3)^2$$

- for $k = 1$, $r = 2$, $N = 4$ and $\Lambda = (5, 3; 2, 0)$, since that Λ is moderately $(1, 2, 4)$ -admissible,

$$P_{(5,3;2,0)}^{\text{SS}}(x_1, x_2, x_3, x_4; -2) = \frac{1}{7}(x_1 - x_2)^2(x_3 - x_4)^2(x_1 - x_3)(x_1 - x_4) \\ \times (x_2 - x_3)(x_2 - x_4)(7x_1x_2 + x_3x_4).$$

The examples above illustrate that the order r is reached in the symmetric part of the polynomial.

Now, to motivate the content of the next section, we show that there are similar clusterings when $k > 1$. For example, by taking $k = 2$, $r = 3$, $N = 4$ and $\lambda = (4, 3, 0, 0)$ (notice that λ is weakly $(2, 3, 4)$ -admissible), we have the symmetric Jack polynomial

$$P_{(4,3,0,0)}(z, z, x_3, x_4; -3/2) = (2z + x_3 + x_4)(z - x_4)^3(z - x_3)^3$$

and if $k = 2$, $r = 3$, $N = 5$ and $\Lambda = (2, 0; 5, 3, 0)$ (notice that Λ is weakly $(2, 3, 5)$ -admissible), we have the Jack polynomial of type AS:

$$P_{(2,0;5,3,0)}^{\text{AS}}(x_1, x_2, x_3, z, z; -3/2) = 2z(x_1 - x_2)(x_1 - 2x_3 + x_2)(x_1 - z)^2(x_2 - z)^2(x_3 - z)^3$$

and we can see that after the identification of k -variables of the symmetric part, the order r is reached in the symmetric part of the polynomial.

4.3 TRANSLATION INVARIANCE

In this section, we first generalize the work of Luque and Jolicoeur about translationally invariant Jack polynomials [37]. We indeed find the necessary and sufficient conditions that guaranties the translational invariance of the Jack polynomial with prescribed symmetry of type AS. To be more precise, let

$$P_\Lambda = P_\Lambda^{\text{AS}}(x_1, \dots, x_N; \alpha), \quad (4.3.1)$$

and suppose that

$$\alpha = \alpha_{k,r}, \quad (4.3.2)$$

$$\Lambda \text{ is a strict and weakly } (k, r, N)\text{-admissible superpartition.} \quad (4.3.3)$$

Then, as was stated in Theorem 4.3.13, P_Λ is invariant under translation if and only if conditions (C1) and (C2) are satisfied. The latter conditions concern the corners in the diagram of Λ . The proof relies on combinatorial formulas obtained in [26] that generalize Lassalle's results [51, 52] about the action of the operator

$$L_+ = \sum_{i=1}^N \frac{\partial}{\partial x_i} \quad (4.3.4)$$

on symmetric Jack polynomials. We now apply the result about the translationally invariant polynomials to prove that certain Jack polynomials with prescribed symmetry AS admit clusters of size k and order r .

4.3.1 GENERATORS OF TRANSLATION

The action of L_+ on a Jack polynomial with prescribed symmetry AS, $P_\Lambda^{\text{AS}}(x; \alpha)$, is in general very complicated. However it can be decomposed in terms of two basic operators, Q_\circ and Q_\square . Their respective action on $P_\Lambda^{\text{AS}}(x; \alpha)$ can be translated into simple transformations of the diagram of Λ , namely the removal of a circle and the conversion of a box into a circle.

Now, let $I = \{1, \dots, m\}$, $I_+ = \{1, \dots, m+1\}$, $I_- = \{1, \dots, m-1\}$, $J = \{m+1, \dots, N\}$, $J_+ = \{m, \dots, N\}$, and $J_- = \{m+2, \dots, N\}$. We define Q_\circ and Q_\square on $\mathcal{A}_I \otimes \mathcal{S}_J$: For $1 \leq m \leq N$,

$$Q_\circ : \mathcal{A}_I \otimes \mathcal{S}_J \longrightarrow \mathcal{A}_{I_-} \otimes \mathcal{S}_{J_+}; f \longmapsto \left(1 + \sum_{i=m+1}^N K_{i,m}\right) f,$$

while for $0 \leq m \leq N-1$,

$$Q_\square : \mathcal{A}_I \otimes \mathcal{S}_J \longrightarrow \mathcal{A}_{I_+} \otimes \mathcal{S}_{J_-}; f \longmapsto \left(1 - \sum_{i=1}^m K_{i,m+1}\right) \circ \frac{\partial f}{\partial x_{m+1}}.$$

Notice that for the extreme case $m=0$, we set $Q_\circ = 0$. Similarly, for $m=N$, we set $Q_\square = 0$.

Lemma 4.3.1. *On the space $\mathcal{A}_I \otimes \mathcal{S}_J$, we have $Q_\circ \circ Q_\square + Q_\square \circ Q_\circ = L_+$.*

Proof. Let f be an element of $\mathcal{A}_I \otimes \mathcal{S}_J$, which means that f is a polynomial in the variables x_1, \dots, x_N that is antisymmetric with respect to x_1, \dots, x_m and symmetric with respect to x_{m+1}, \dots, x_N . We must show that

$$(Q_\circ \circ Q_\square)(f) + (Q_\square \circ Q_\circ)(f) = \sum_{i=1}^N \frac{\partial f}{\partial x_i}. \quad (4.3.5)$$

On the one hand,

$$\begin{aligned} (Q_\circ \circ Q_\square)(f) &= \frac{\partial f}{\partial x_{m+1}} - \sum_{i=1}^m K_{i,m+1} \frac{\partial f}{\partial x_{m+1}} \\ &+ \sum_{j=m+2}^N K_{j,m+1} \frac{\partial f}{\partial x_{m+1}} - \sum_{j=m+2}^N K_{j,m+1} \sum_{i=1}^m K_{i,m+1} \frac{\partial f}{\partial x_{m+1}}. \end{aligned} \quad (4.3.6)$$

However, the symmetry properties of f imply

$$\begin{aligned} \sum_{j=m+2}^N K_{j,m+1} \frac{\partial f}{\partial x_{m+1}} &= \sum_{j=m+2}^N \frac{\partial f}{\partial x_j} \\ \text{and } \sum_{j=m+2}^N K_{j,m+1} \sum_{i=1}^m K_{i,m+1} \frac{\partial f}{\partial x_{m+1}} &= \sum_{i=1}^m \sum_{j=m+2}^N \frac{\partial}{\partial x_i} (K_{i,j} f). \end{aligned} \quad (4.3.7)$$

By substituting the last equalities into (4.3.6), we obtain

$$(Q_\circ \circ Q_\square)(f) = \frac{\partial f}{\partial x_{m+1}} + \sum_{j=m+2}^N \frac{\partial f}{\partial x_j} - \sum_{i=1}^m \sum_{j=m+1}^N \frac{\partial}{\partial x_i} (K_{i,j} f). \quad (4.3.8)$$

On the other hand,

$$(Q_{\square} \circ Q_{\circ})(f) = \frac{\partial f}{\partial x_m} + \sum_{j=m+1}^N \frac{\partial}{\partial x_m} (K_{j,m} f) - \sum_{i=1}^{m-1} K_{i,m} \frac{\partial f}{\partial x_m} - \sum_{i=1}^{m-1} K_{i,m} \frac{\partial}{\partial x_m} \left(\sum_{j=m+1}^N K_{j,m} f \right). \quad (4.3.9)$$

Once again, the symmetry properties of f allow to simplify this equation. Indeed,

$$\sum_{i=1}^{m-1} K_{i,m} \frac{\partial f}{\partial x_m} = - \sum_{i=1}^{m-1} \frac{\partial f}{\partial x_i}$$

and

$$\sum_{i=1}^{m-1} K_{i,m} \frac{\partial}{\partial x_m} \left(\sum_{j=m+1}^N K_{j,m} f \right) = - \sum_{i=1}^{m-1} \sum_{j=m+1}^N \frac{\partial}{\partial x_i} (K_{i,j} f).$$

Then,

$$(Q_{\square} \circ Q_{\circ})(f) = \frac{\partial f}{\partial x_m} + \sum_{i=1}^{m-1} \frac{\partial f}{\partial x_i} + \sum_{i=1}^m \sum_{j=m+1}^N \frac{\partial}{\partial x_i} (K_{i,j} f). \quad (4.3.10)$$

We finally sum equations (4.3.8) and (4.3.10). This yields equation (4.3.5), as expected. \square

The explicit action of Q_{\circ} and Q_{\square} on the polynomial $P_{\Lambda}^{\text{AS}}(x; \alpha)$ can be read off from Proposition 9 of [26] and we state it explicitly below in Proposition 4.3.2. Indeed, this proposition is concerned with the action of differential operators – related to the super-Virasoro algebra – on the Jack superpolynomials, denoted by $P_{\Lambda}(x; \theta; \alpha)$, which contain Grassmann variables $\theta_1, \dots, \theta_N$. Among the operators studied in [26], there are

$$Q^{\perp} = \sum_i \frac{\partial}{\partial \theta_i} \quad \text{and} \quad q = \sum_i \theta_i \frac{\partial}{\partial x_i}.$$

Now, a Jack superpolynomial of degree m in the variables θ_i , can be decomposed as follows [22]:

$$P_{\Lambda}(x; \theta; \alpha) = \sum_{1 \leq j_1 < \dots < j_m \leq N} \theta_{j_1} \dots \theta_{j_m} f^{j_1, \dots, j_m}(x; \alpha),$$

where $f^{j_1, \dots, j_m}(x; \alpha)$ belongs to the space $\mathcal{A}_{\{j_1, \dots, j_m\}} \otimes \mathcal{S}_{\{1, \dots, N\} \setminus \{j_1, \dots, j_m\}}$ and is an eigenfunction of the operator D defined in (1.1.3). This means in particular

that $f^{1,\dots,m}(x; \alpha)$ is exactly equal to our $P_\Lambda^{\text{AS}}(x; \alpha)$. It is then an easy exercise to show that the formula for the action of Q^\perp on $P_\Lambda(x; \theta; \alpha)$ provides the formula for the action of Q_\circ on $P_\Lambda^{\text{AS}}(x; \alpha)$. Similarly, $qP_\Lambda(x; \theta; \alpha)$ is related to $Q_\square P_\Lambda^{\text{AS}}(x; \alpha)$. Notice that the formulas obtained in [26] are given in terms of the following upper and lower-hook lengths:

$$\begin{aligned} h_\Lambda^{(\alpha)}(s) &= l_{\Lambda^\circledast}(s) + \alpha(a_{\Lambda^*}(s) + 1) \\ h_\alpha^{(\Lambda)}(s) &= l_{\Lambda^*}(s) + 1 + \alpha(a_{\Lambda^\circledast}(s)) \end{aligned} \quad (4.3.11)$$

Proposition 4.3.2. [26] *The action of the operators Q_\circ and Q_\square on the Jack polynomial with prescribed symmetry $P_\Lambda = P_\Lambda^{\text{AS}}(x; \alpha)$ is*

$$Q_\circ(P_\Lambda) = \sum_{\Omega} (-1)^{\#\Omega^\circ} \left(\prod_{s \in \text{row}_{\Omega^\circ}} \frac{h_\alpha^{(\Omega)}(s)}{h_\alpha^{(\Lambda)}(s)} \right) (N + 1 - i + \alpha(j - 1)) P_\Omega \quad (4.3.12)$$

$$Q_\square(P_\Lambda) = \sum_{\Omega} (-1)^{\#\Omega^\circ} \left(\prod_{s \in \text{row}_{\Omega^\circ}} \frac{h_\Lambda^{(\alpha)}(s)}{h_\Omega^{(\alpha)}(s)} \right) P_\Omega \quad (4.3.13)$$

where the sum is taken in (4.3.12) over all Ω 's obtained by removing a circle from Λ ; while the sum in (4.3.13) is taken over all Ω 's obtained by converting a box of Λ into a circle. Also, in each case Λ and Ω differ in exactly one cell which we call the marked cell and whose position is denoted in the formulas by (i, j) . The symbol $\#\Omega^\circ$ stands for the number of circles in Ω above the marked cell. The symbol $\text{row}_{\Omega^\circ}$ stands for the row of Ω and Λ to the left of the marked cell.

Example 4.3.3. *Given $\Lambda = (4, 3; 2, 2)$, through the action of Q_\square on P_Λ we obtain one Jack polynomial with prescribed symmetry indexed by the superpartition Ω ,*

$$\Lambda = \begin{array}{cccc} \square & \square & \square & \square \\ \square & \square & \square & \circ \\ \square & \square & & \\ \square & \square & & \end{array} \xrightarrow{Q_\square} \Omega = \begin{array}{cccc} \square & \square & \square & \square \\ \square & \square & \square & \circ \\ \square & \square & & \\ \square & \circ & & \end{array}$$

and then, acting with Q_\circ on P_Ω we obtain a lineal combination of Jack polynomials with prescribed symmetry indexed by the superpartitions Γ ,

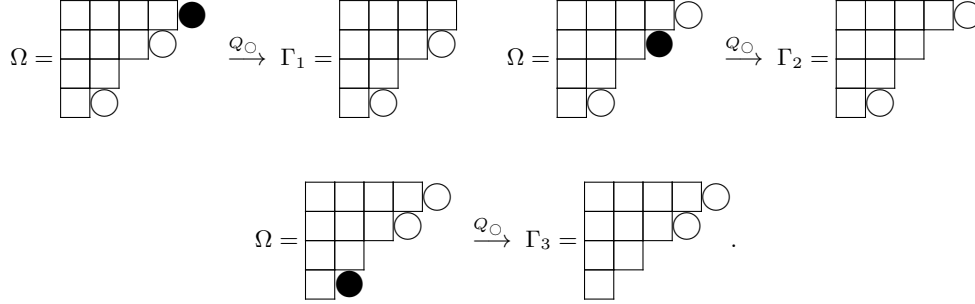

But if we act first with Q_{\circ} on P_{Λ} we obtain a lineal combination of two Jack polynomials with prescribed symmetry indexed by the superpartitions Ω ,

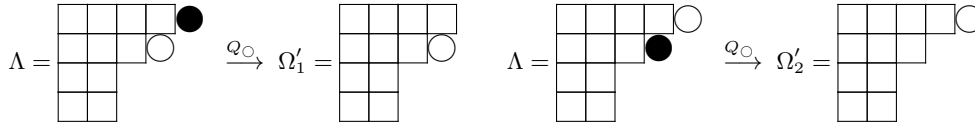

and then acting with Q_{\square} on each P_{Ω} we obtain a new lineal combination of Jack polynomials with prescribed symmetry indexed by the superpartitions Γ ,

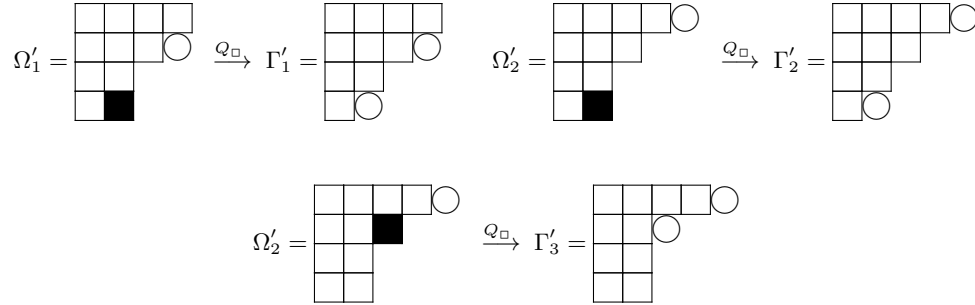

Algebraically we have

$$Q_{\circ}(Q_{\square}P_{\Lambda}) = d_{\Omega, \Gamma_1} c_{\Lambda, \Omega} P_{\Gamma_1} + d_{\Omega, \Gamma_2} c_{\Lambda, \Omega} P_{\Gamma_2} + d_{\Omega, \Gamma_3} c_{\Lambda, \Omega} P_{\Gamma_3}$$

$$Q_{\square}(Q_{\circ}P_{\Lambda}) = d_{\Omega'_1, \Gamma'_1} c_{\Lambda, \Omega'_1} P_{\Gamma'_1} + d_{\Omega'_2, \Gamma'_2} c_{\Lambda, \Omega'_2} P_{\Gamma'_2} + d_{\Omega'_2, \Gamma'_3} c_{\Lambda, \Omega'_2} P_{\Gamma'_3}.$$

where the coefficients c and d are obtained from the product of hooks specified in 4.3.12 and 4.3.13.

Remark 4.3.4. Let Λ be a superpartition such that in the corresponding diagram, all corners are boxes. Then, in equation (4.3.12), we cannot remove any circle from the diagram of Λ and we are forced to conclude that $Q_{\circ}P_{\Lambda} = 0$. This

is coherent with the fact that in such case, $P_{\Lambda}^{\text{AS}}(x; \alpha)$ is a symmetric polynomial and according with our convention, $Q_{\circ} f = 0$ for all $f \in \mathcal{S}_{\{1, \dots, N\}}$.

Similarly, if Λ is a superpartition such that in its diagram, all corners are circles, then we cannot transform a box in the diagram of Λ into a circle. This is coherent with our convention. Indeed, in such case, $P_{\Lambda}^{\text{AS}}(x; \alpha)$ is an antisymmetric polynomial and we have set $Q_{\square} f = 0$ for all $f \in \mathcal{A}_{\{1, \dots, N\}}$.

4.3.2 GENERAL INVARIANCE

In this section we determine whether a Jack polynomial with prescribed symmetry is translationally invariant by looking at the shape of the diagram associated to the indexing superpartition. We pay a special attention to the corners in the diagram.

Definition 4.3.5. Let D be the diagram associated to the superpartition Λ . The cell $(i, j) \in D$ is a corner if $(i + 1, j) \notin D$ and $(i, j + 1) \notin D$. We say that the corner (i, j) is an outer corner if the row $i - 1$ and the column $j - 1$ do not have corners. We also define a corner (i, j) to be an inner corner if the row $i - 1$ and the column $j - 1$ have corners. A corner that neither outer nor inner is called a bordering corner. Note that in the above definitions, it is assumed that each point of the form $(0, j)$ or $(i, 0)$ is a corner.

Example 4.3.6. In the following diagram we specify the corners and corner's type (outer c., inner c. or bordering c.).

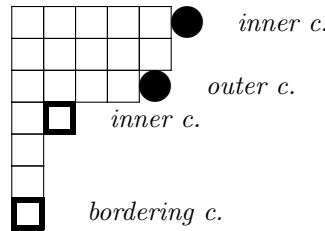

Lemma 4.3.7. Let D' be the diagram obtained by removing the corner (i, j) from diagram D , which contains c corners. Then, the number of corners in D' is:

- $c - 1$ if (i, j) is an inner corner;

- c if (i, j) is a bordering corner;
- $c + 1$ if (i, j) is an outer corner.

Proof. This follows immediately from the above definitions. \square

Lemma 4.3.8. *Assume (4.3.1), (4.3.2), and (4.3.3). Then, $Q_{\square}(P_{\Lambda}) = 0$ if and only if Λ is such that all the corners in its diagram are circles.*

Proof. According to Proposition 4.3.2, $Q_{\square}(P_{\Lambda})$ vanishes if and only if each corner of Λ is either a circle or a box located at (i, j') such that for some $j < j'$, we have

$$h_{\Lambda}^{(\alpha_{k,r})}(i, j) = l_{\Lambda^{\otimes}}(i, j) + \alpha_{k,r}(a_{\Lambda^*}(i, j) + 1) = 0$$

Now, $h_{\Lambda}^{(\alpha_{k,r})}(i, j) = 0$ only if for some positive integer \bar{k} , we have $a_{\Lambda^*}(i, j) + 1 = \bar{k}(r - 1)$ and $l_{\Lambda^{\otimes}}(i, j) = (k + 1)\bar{k}$. This implies

$$\Lambda_i^{\otimes} - \Lambda_{i+\bar{k}(k+1)}^* \leq \bar{k}r - \bar{k}. \quad (4.3.14)$$

On the other hand, Lemma 3.1.2 implies that $\Lambda_{i+1}^{\otimes} - \Lambda_{i+\bar{k}(k+1)}^* \geq \bar{k}r$. Moreover, $\Lambda_i^{\otimes} \geq \Lambda_{i+1}^{\otimes}$, so that $\Lambda_i^{\otimes} - \Lambda_{i+\bar{k}(k+1)}^* \geq \bar{k}r$. This inequality contradicts (4.3.14).

Therefore, if Λ is a (k, r, N) -admissible superpartition, $Q_{\square}(P_{\Lambda})$ vanishes if and only if all the corners in Λ are circles. \square

The conditions for the vanishing of the action of Q_{\circlearrowleft} on a Jack polynomial with prescribed symmetry are more involved. They require a finer characterization of the different types of hooks formed from the corners of the diagrams.

Definition 4.3.9. *Let D be the diagram associated to the superpartition Λ . Let $(i, j) \in D$ be a circled corner. We say that (i, j) is the upper corner of a hook of type:*

- $C_{k,r}$ if the box $(i, j - r) \in D$ and it satisfies $l_{\Lambda^*}(i, j - r) = l_{\Lambda^{\otimes}}(i, j - r) = k$;
- $\tilde{C}_{k,r}$ if the box $(i, j - r) \in D$ and it satisfies $l_{\Lambda^*}(i, j - r) = k$ together with $l_{\Lambda^{\otimes}}(i, j - r) = k + 1$.

Similarly, when $(i, j) \in D$ is a boxed corner, we say (i, j) is the upper corner of a hook of type:

- c) $B_{k,r}$ if the box $(i, j - r) \in D$ and it satisfies $l_{\Lambda^*}(i, j - r) = l_{\Lambda^\circledast}(i, j - r) = k$.
- d) $\tilde{B}_{k,r}$ if the box $(i, j - r) \in D$ and it satisfies $l_{\Lambda^*}(i, j - r) = k$ together with $l_{\Lambda^\circledast}(i, j - r) = k + 1$.

The hooks are illustrated in Figure 4.1.

Let us consider a concrete example. For this we fix $k = 4$, $r = 3$ and $N = 18$ and we consider the following $(4, 3, 18)$ -admissible superpartition:

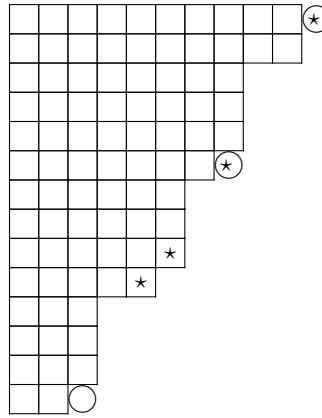

Each cell marked with a star is the upper corner of one of the four types of hooks. The first one, located at the position $(1, 11)$, is the upper corner of a hook of type $\tilde{C}_{4,3}$. The second, located at the position $(6, 8)$, belongs to a hook of type $C_{4,3}$. Similarly, the third and the fourth corners, are the upper corners of hooks of type $\tilde{B}_{4,3}$ and $B_{4,3}$, respectively.

Lemma 4.3.10. *Assume (4.3.1), (4.3.2), and (4.3.3). Then, $Q_{\circ}(P_{\Lambda}) = 0$ if and only if each corner in the diagram of Λ is either:*

- (i) a box;
- (ii) a circle and the upper corner of a hook of type $C_{k,r}$ or $\tilde{C}_{k,r}$;
- (iii) a circle with coordinates (i, j) such that $i = N + 1 - \bar{k}(k + 1)$ and $j = \bar{k}(r - 1) + 1$ for some positive integer \bar{k} .

Note that there is at most one corner (i, j) satisfying the criterion (iii).

Proof. According to Proposition 4.3.2, $Q_{\circ}(P_{\Lambda}) = 0$ iff, each corner (i, j) satisfies at least one of the following criteria:

1. the cell (i, j) is a box;
2. the cell (i, j) is a circle and there is a $j' < j$ such that $h_{\alpha}^{(\Omega)}(i, j') = 0$, where $h_{\alpha}^{(\Omega)}(i, j') = l_{\Omega^*}(i, j') + 1 + \alpha_{k,r}(a_{\Omega^{\otimes}}(i, j'))$ and Ω is the diagram obtained from Λ by removing the circle in (i, j) ;
3. the cell (i, j) is a circle and it is such that $N + 1 - i + \alpha_{k,r}(j - 1) = 0$.

The first criterion being trivial, we turn to the second. Obviously, $h_{\alpha}^{(\Omega)}(i, j') = 0$ iff there exists a positive integer \bar{k} such that $a_{\Omega^{\otimes}}(i, j') = \bar{k}(r - 1)$ and $l_{\Omega^*}(i, j') = \bar{k}(k + 1) - 1$. The first condition is equivalent to $j - j' = \bar{k}(r - 1) - 1$. The second is equivalent to say that $\Lambda_{i+\bar{k}(k+1)-1}^* \geq j'$ and that the cell $(i + \bar{k}k + \bar{k}, j')$ is empty or a circle. Suppose further that $\bar{k} = 1$. Then, we have shown that $h_{\alpha}^{(\Omega)}(i, j') = 0$ iff $j' = j - r + 2$, $\Lambda_{i+k}^* \geq j'$ and $\Lambda_{i+k+1}^* < j'$ (i.e., $\Lambda_{i+k+1}^{\otimes} < j'$ or $\Lambda_{i+k+1}^{\otimes} = j'$), this corresponds to the two hooks given above. Now, suppose $\bar{k} = 2$. On the one hand, we have $\Lambda_{i+2k+1}^* \geq j' = j - 2(r - 1) + 1 = \Lambda_i^{\otimes} - 2(r - 1) + 1$, i.e.,

$$\Lambda_i^{\otimes} - \Lambda_{i+2k+1}^* \leq 2r - 3. \quad (4.3.15)$$

On the other hand, the admissibility requires $\Lambda_i^{\otimes} - \Lambda_{i+k}^* \geq r$ and $\Lambda_{i+k}^* - \Lambda_{i+2k}^* \geq r - 1$. Then,

$$\Lambda_i^{\otimes} - \Lambda_{i+2k+1}^* \geq \Lambda_i^{\otimes} - \Lambda_{i+2k}^* \geq 2r - 1. \quad (4.3.16)$$

Inequalities (4.3.15) and (4.3.16) are contradictory, so we conclude that \bar{k} cannot be equal to 2. In the same way, one easily shows that \bar{k} cannot be greater than 2.

Now consider the third criterion. As $N + 1 - i > 0$, the factor $N + 1 - i + \alpha_{k,r}(j - 1)$ vanishes iff $j = \bar{k}(r - 1) + 1$ and $N = i + \bar{k}(k + 1) - 1$, for some positive integer \bar{k} . Now suppose there is another corner (i', j') such that $N + 1 - i' + \alpha_{k',r}(j' - 1)$. Then, $j' = \bar{k}'(r - 1) + 1$ and $N = i' + \bar{k}'(k + 1) - 1$, for some positive integer \bar{k}' . Without loss of generality, we can assume $i < i'$, which implies $j > j'$, i.e. $\bar{k} > \bar{k}'$. Let $n = \bar{k} - \bar{k}'$. Then, $j - j' = \Lambda_i^{\otimes} - \Lambda_{i'}^{\otimes} = n(r - 1)$, which implies $\Lambda_i^{\otimes} - \Lambda_{i'}^{\otimes} = n(r - 1) + 1$. Using $N = i + \bar{k}(k + 1) - 1 = i' + \bar{k}'(k + 1) - 1$, we get $i' = i + n(k + 1)$. Also, $\Lambda_i^{\otimes} - \Lambda_{i+n(k+1)}^{\otimes} > \Lambda_i^{\otimes} - \Lambda_{i+nk}^{\otimes}$, thus

$$\Lambda_i^{\otimes} - \Lambda_{i+nk}^{\otimes} \leq n(r - 1). \quad (4.3.17)$$

However, by using the admissibility and the fact that

$$\Lambda_i^{\otimes} - \Lambda_{i+nk}^{\otimes} = \Lambda_i^{\otimes} - \Lambda_{i+k}^{\otimes} + \Lambda_{i+k}^{\otimes} - \Lambda_{i+2k}^{\otimes} + \Lambda_{i+2k}^{\otimes} - \Lambda_{i+3k}^{\otimes} + \dots + \Lambda_{i+(n-1)k}^{\otimes} - \Lambda_{i+nk}^{\otimes}, \quad (4.3.18)$$

one easily shows that

$$\Lambda_i^{\otimes} - \Lambda_{i+nk}^{\otimes} \geq r + (n - 1)(r - 1) = nr - n + 1. \quad (4.3.19)$$

Obviously, equations (4.3.17) and (4.3.19) are contradictory. Therefore no more than one corner is such that $N + 1 - i + \alpha_{k,r}(j - 1) = 0$. \square

Corollary 4.3.11. *Assume (4.3.1), (4.3.2), and (4.3.3). Suppose moreover that the last corner in Λ 's diagram is a circle. Let (ℓ, j) the coordinates of the last corner. Then, $Q_{\circ}(P_{\Lambda}) = 0$ only if $N = \ell + k$ and $j = r$.*

Proof. According to the previous proposition, as (ℓ, j) cannot be the upper corner of a hook, $Q_{\circ}(P_{\Lambda}) = 0$ only if the condition (iii) is met for the corner (ℓ, j) . This means that $Q_{\circ}(P_{\Lambda}) = 0$ only if $\ell = N + 1 - \bar{k}(k + 1)$ and $j = \bar{k}(r - 1) + 1$ for some positive integer \bar{k} . Now, the admissibility condition requires $\ell + k \geq N$, i.e.,

$$N + 1 - \bar{k}(k + 1) + k \geq N.$$

This is true iff $\bar{k} = 1$. Thus, $Q_{\circ}(P_{\Lambda}) = 0$ only if $\ell = N - k$ and $j = r$. \square

Proposition 4.3.12. *Assume (4.3.1), (4.3.2), and (4.3.3). Then, P_{Λ} is invariant under translation if and only if $Q_{\square}(Q_{\circ}P_{\Lambda}) = 0$ and $Q_{\circ}(Q_{\square}P_{\Lambda}) = 0$.*

Proof. Clearly, P_Λ is translationally invariant iff $L_+(P_\Lambda) = 0$. Moreover, we know from Lemma 4.3.1 that $L_+(P_\Lambda) = Q_\square(Q_\circ P_\Lambda) + Q_\circ(Q_\square P_\Lambda)$. Thus, if $Q_\square(Q_\circ P) = 0$ and $Q_\circ(Q_\square P) = 0$ then $L_+P = 0$.

It remains to show that if $L_+P = 0$, then $Q_\square(Q_\circ P_\Lambda) = 0$ and $Q_\circ(Q_\square P_\Lambda) = 0$. In fact, we are going to prove the contrapositive: if $Q_\square(Q_\circ P_\Lambda) \neq 0$ or $Q_\circ(Q_\square P_\Lambda) \neq 0$ then $L_+P \neq 0$. However, if $Q_\square(Q_\circ P_\Lambda) \neq 0$ and $Q_\circ(Q_\square P_\Lambda) = 0$, or if $Q_\square(Q_\circ P_\Lambda) = 0$ and $Q_\circ(Q_\square P_\Lambda) \neq 0$, then automatically $L_+P_\Lambda \neq 0$. Consequently, we need to prove the following statement:

$$Q_\square(Q_\circ P_\Lambda) \neq 0 \quad \text{and} \quad Q_\circ(Q_\square P_\Lambda) \neq 0 \quad \implies \quad Q_\square Q_\circ(P_\Lambda) + Q_\circ Q_\square(P_\Lambda) \neq 0. \quad (4.3.20)$$

We assume that $Q_\square(Q_\circ P_\Lambda) \neq 0$ and $Q_\circ(Q_\square P_\Lambda) \neq 0$. Then, $Q_\circ P_\Lambda \neq 0$ and $Q_\square P_\Lambda \neq 0$. According to Lemma 4.3.10, the first equation implies that there is at least one circle in the diagram of Λ that does not satisfy the conditions (ii) and (iii). Let (i, j) denote the position of such a circle. Moreover, according to Lemma 4.3.8, the second equation implies that there must be at least one boxed corner in the diagram of Λ . Let (\bar{i}, \bar{j}) be its position.

Let Υ be the superpartition obtained from Λ by removing the circle (i, j) and by converting a box (\bar{i}, \bar{j}) into a circle. There is only one way to get P_Υ by acting with $Q_\square Q_\circ$ on P_Λ by acting with $Q_\circ Q_\square$ on P_Λ . Thus, it is enough to verify that the coefficients of the polynomial P_Υ in the expansions of $Q_\square(Q_\circ P_\Lambda)$ and $Q_\circ Q_\square(P_\Lambda)$ are not the same (up to a sign).

Let Ω^1 be the superpartition obtained from Λ by removing the circle in (i, j) . Clearly, the coefficient of P_Υ in $Q_\square(Q_\circ P_\Lambda)$ is equal to the product of two coefficients: c_{Λ, Ω^1} , the coefficient of P_{Ω^1} in $Q_\circ(P_\Lambda)$, and $b_{\Omega^1, \Upsilon}$, the coefficient of P_Υ in $Q_\square(P_{\Omega^1})$. Similarly, if Ω^2 denotes the superpartition obtained from Λ by converting the box (\bar{i}, \bar{j}) into a circle, then the coefficient of P_Υ in $Q_\circ(Q_\square P_\Lambda)$ is the product of the two following coefficients: b_{Λ, Ω^2} , the coefficient of P_{Ω^2} in $Q_\square P_\Lambda$, and $c_{\Omega^2, \Upsilon}$, the coefficient of P_Υ in $Q_\circ(P_{\Omega^2})$. In short,

$$Q_\square Q_\circ(P_\Lambda) = c_{\Lambda, \Omega^1} b_{\Omega^1, \Upsilon} P_\Upsilon + \dots \quad (4.3.21)$$

$$Q_\circ Q_\square(P_\Lambda) = b_{\Lambda, \Omega^2} c_{\Omega^2, \Upsilon} P_\Upsilon + \dots \quad (4.3.22)$$

where \dots indicates terms linearly independent from P_Υ . We recall that the coefficients b and c can be read off the equations in Proposition 4.3.2.

Now, we need to distinguish two cases: (1) the box is located above the circle in the diagram of Λ , which means $\bar{i} < i$, and (2) the box is located under the circle in the diagram of Λ , which means $\bar{i} > i$.

Suppose first that the box is located above the circle, i.e., $\bar{i} < i$. Obviously, b_{Λ, Ω^2} is not zero. Moreover, $c_{\Omega^2, \Upsilon}$ is equal to c_{Λ, Ω^1} . This can be understood as follows. These coefficients depend only on N , the coordinates of the marked cell, which are (i, j) in both cases, and on ratios of hook-lengths for the cells in the row to the left of the marked cell. Given that the marked cell is below the cell (\bar{i}, \bar{j}) , the hook-lengths involved in the coefficients are not affected by any prior transformation $\Lambda \rightarrow \Omega^2$, so the coefficients are equal. The situation is not so simple for b_{Λ, Ω^2} and $b_{\Omega^1, \Upsilon}$, so explicit formulas for these coefficients are required. Up to a sign, they are

$$d_{\Lambda, \Omega^2} = \left(\prod_{1 \leq l \leq \bar{j}-1} \frac{h_{\Lambda}^{(\alpha)}(\bar{i}, l)}{h_{\Omega^2}^{(\alpha)}(\bar{i}, l)} \right), \quad d_{\Omega^1, \Upsilon} = \left(\prod_{1 \leq l \leq \bar{j}-1} \frac{h_{\Omega^1}^{(\alpha)}(\bar{i}, l)}{h_{\Upsilon}^{(\alpha)}(\bar{i}, l)} \right) \quad (4.3.23)$$

It is important to note that

$$h_{\Lambda}^{(\alpha)}(\bar{i}, l) = h_{\Omega^1}^{(\alpha)}(\bar{i}, l) \quad \forall 1 \leq l \leq \bar{j} - 1, \quad l \neq j$$

and for $l = j$ we have

$$\begin{aligned} h_{\Lambda}^{(\alpha)}(\bar{i}, j) &= (i - \bar{i}) + \alpha(\bar{j} - j + 1) \\ h_{\Omega^1}^{(\alpha)}(\bar{i}, j) &= (i - \bar{i} - 1) + \alpha(\bar{j} - j + 1) \end{aligned} \quad (4.3.24)$$

Also, for $l \neq j$,

$$h_{\Omega^2}^{(\alpha)}(\bar{i}, l) = h_{\Upsilon}^{(\alpha)}(\bar{i}, l) \quad \forall 1 \leq l \leq \bar{j} - 1,$$

while for $l = j$,

$$\begin{aligned} h_{\Omega^2}^{(\alpha)}(\bar{i}, j) &= (i - \bar{i}) + \alpha(\bar{j} - j) \\ h_{\Upsilon}^{(\alpha)}(\bar{i}, j) &= (i - \bar{i} - 1) + \alpha(\bar{j} - j). \end{aligned} \quad (4.3.25)$$

After having made basic calculations, we see that the coefficients b_{Λ, Ω^2} and $b_{\Omega^1, \Upsilon}$ are equal iff $\alpha = 0$. We thus conclude that $b_{\Lambda, \Omega^2} \neq \pm b_{\Omega^1, \Upsilon}$, which in turn implies that $c_{\Lambda, \Omega^1} b_{\Omega^1, \Upsilon} \pm b_{\Lambda, \Omega^2} c_{\Omega^2, \Upsilon} \neq 0$.

The second case, for which the square is located under the circle in the Λ diagram, is very similar to the case just analyzed. The only difference for the

second case is that $b_{\Lambda, \Omega^2} = \pm b_{\Omega^1, \Upsilon}$ and $c_{\Omega^2, \Upsilon} \neq \pm c_{\Lambda, \Omega^1}$. Nevertheless, this implies once again that $c_{\Lambda, \Omega^1} b_{\Omega^1, \Upsilon} \pm b_{\Lambda, \Omega^2} c_{\Omega^2, \Upsilon} \neq 0$.

In conclusion, we have proved equation (4.3.20) and the proposition follows. \square

For instance, fixing $k = 2$, $r = 3$, $N = 5$ and $n \leq 10$ we get 18 admissible superpartitions:

$$\begin{aligned} & (4, 2; 3, 0, 0), (4, 3, 2; 0, 0), (4, 2, 0; 3, 0), (4, 3, 2, 0; 0), (2; 5, 3, 0, 0), (5, 2; 3, 0, 0), \\ & (3, 2; 5, 0, 0), (2, 0; 5, 3, 0), (4, 2; 4, 0, 0), (5, 3, 2; 0, 0), (5, 2, 0; 3, 0), (3, 2, 0; 5, 0), \\ & (4, 2, 0; 4, 0), (4, 3, 2; 1, 0), (5, 3, 2, 0; 0), (4, 3, 2, 1; 0), (4, 3, 2, 0; 1), (4, 3, 2, 1, 0; \emptyset) \end{aligned}$$

which 6 indexed Jack polynomials invariant under translation:

$$(2; 5, 3, 0, 0), (4, 2; 3, 0, 0), (4, 2, 0; 3, 0), (4, 3, 2; 0, 0), (4, 3, 2, 0; 0), (4, 3, 2, 1, 0; \emptyset).$$

In the following theorem we give the necessary and sufficient conditions that characterize the Jack polynomials with prescribed symmetry which are invariant under translation.

Theorem 4.3.13 (Translation invariance). *Let Λ be a strict and weakly (k, r, N) -admissible superpartition. Then, the Jack polynomial with prescribed symmetry $P_{\Lambda}^{\text{AS}}(x; \alpha_{k,r})$ is invariant under translation if and only if one of the following two conditions is satisfied:*

- (C1) *all corners (circles or boxes) of Λ are located at the upper corner of a hook of type $B_{k,r}$, $\tilde{B}_{k,l}$, $C_{k,r}$, or $\tilde{C}_{k,l}$, except for one corner, which must be located at the point $(N - k, r)$;*
- (C2) *all corners of Λ are circles such that if they are not interior, they are located at the upper corner of a hook of type $C_{k,r}$ or $\tilde{C}_{k,l}$, except for at most one non-interior corner (i, j) , which is such that $i = N + 1 - \bar{k}(k + 1)$ y $j = \bar{k}(r - 1) + 1$ for some \bar{k} .*

Types of hooks are given in Figure 4.1. Interior and non-interior corners are defined in Definition 4.3.5.

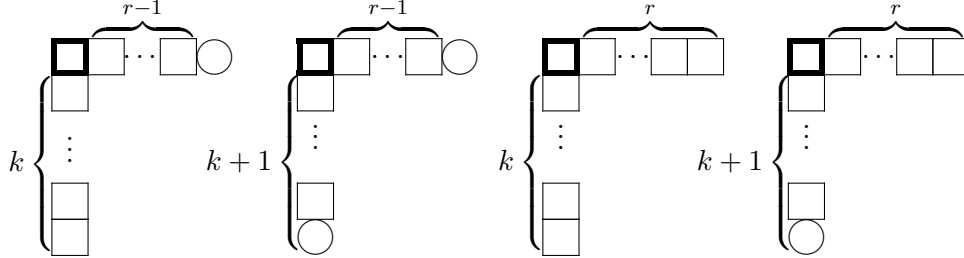
Figure 4.1: Types of hooks. From left to right, $C_{k,r}$, $\tilde{C}_{k,r}$, $B_{k,r}$ and $\tilde{B}_{k,r}$ 

Proof. In what follows, $P_\Lambda = P_\Lambda(x_1, \dots, x_N; \alpha_{k,r})$, where Λ is as in (4.3.3). We suppose moreover that the diagram of Λ contains exactly m circles.

According to Proposition 4.3.12, P_Λ is invariant under translation iff it belongs simultaneously to the kernel of $Q_\square \circ Q_\circ$ and that of $Q_\circ \circ Q_\square$.

Consider first $Q_\square \circ Q_\circ(P_\Lambda) = 0$. It is clear that $Q_\square \circ Q_\circ(P_\Lambda) = 0$ iff $Q_\circ(P_\Lambda) = 0$ or, according to lemma 4.3.8, $Q_\circ(P_\Lambda)$ generates Jack polynomials indexed by superpartitions whose corners are all circles. On the one hand, $Q_\circ(P_\Lambda) = 0$ iff Λ belongs to the set \mathcal{B} formed by all superpartitions satisfying conditions (i),(ii) and (iii) of Lemma 4.3.10. On the other hand, $Q_\circ(P_\Lambda) \neq 0$ and $Q_\square \circ Q_\circ(P_\Lambda) = 0$ iff each corner of Λ is a circle such that if we delete it, we obtain a new superpartition whose corners are all circles, except possibly some that satisfy the conditions ii) or iii) of Lemma 4.3.10 (by assumption not all circles of Λ satisfy these conditions). We call \mathcal{C} the set of all such superpartitions. Now, by Lemma 4.3.7, the elimination of a circle does not create a corner with box iff the circle is an inner corner. Then, \mathcal{C} is given by the set of all superpartitions whose corners are all inner circles except possibly some that satisfy the conditions ii) or iii). It is interesting to note that the only superpartition having only circled inner corners is the staircase $\delta_m = (m-1, m-2, \dots, 1, 0; \emptyset)$, which is (k, r, N) -admissible if $N \leq k$, or $N > k$ and $k \geq r-1$. Therefore, $Q_\square \circ Q_\circ(P_\Lambda) = 0$ iff Λ belongs to the set \mathcal{B} , or the set \mathcal{C} .

So far, we have shown that $Q_\square \circ Q_\circ(P_\Lambda) = 0$ iff $\Lambda \in \mathcal{B} \cup \mathcal{C}$. It remains to determine the subset $\mathcal{A} \subset \mathcal{B} \cup \mathcal{C}$ such that $\Lambda \in \mathcal{A} \implies L_+(P_\Lambda) = 0$. The simplest case is $\Lambda \in \mathcal{C}$. Indeed, since all corners of Λ are circles, we automatically have $Q_\square(P_\Lambda) = 0$, which implies $Q_\circ \circ Q_\square(P_\Lambda) = 0$ and $L_+(P_\Lambda) = 0$.

We now suppose that $\Lambda \in \mathcal{B}$. We want to determine the necessary and sufficient criteria for $Q_{\circ} \circ Q_{\square}(P_{\Lambda}) = 0$. On the one hand, we know that $Q_{\square}(P_{\Lambda}) = 0$ iff all corners of Λ are circles. Therefore, $Q_{\square}(P_{\Lambda}) = 0$ and $\Lambda \in \mathcal{B}$ iff all corners are circles that satisfy conditions (ii) and (iii) of Lemma 4.3.10. Now, if $\Lambda \in \mathcal{B}$ and has at least one boxed corner in (i, j) , then $Q_{\square}(P_{\Lambda})$ does not vanish and generates P_{Ω} , where Ω is the superpartition obtained from Λ by converting the box (i, j) into a circle. Now, $Q_{\circ}(P_{\Omega})$ vanishes iff all corners of Ω satisfy any of the three conditions of Lemma 4.3.10. Since by hypothesis Λ already complies with these conditions, $Q_{\circ}(P_{\Omega}) = 0$ iff (i, j) in Ω is the upper corner of the hook $C_{k,r}$ or $\tilde{C}_{k,r}$, or it is such that $i = N + 1 - \bar{k}(k + 1)$ and $j = \bar{k}(r - 1) + 1$ for some positive integer \bar{k} (what is possible only once). Applying this result to each boxed corner of Λ , we get $Q_{\circ}(Q_{\square}(P_{\Lambda})) = 0$ iff each boxed corner of Λ is the upper corner of a hook $B_{k,r}$ or $\tilde{B}_{k,r}$, or it is such that $i = N + 1 - \bar{k}(k + 1)$ and $j = \bar{k}(r - 1) + 1$ for some positive integer \bar{k} .

Finally, let (ℓ, j') the coordinates of the last corner $\Lambda \in \mathcal{B}$. Obviously, if there is a circle in (ℓ, j') , this circle also corresponds to the last corner of any superpartition Ω indexing the Jack polynomials generated by $Q_{\square}(P_{\Lambda})$. According to Corollary 4.3.11, we know that $Q_{\circ} \circ Q_{\square}(P_{\Lambda}) = 0$ only if $\ell = N - k$ and $j = r$. On the other hand, if the last corner Λ is a box, it is known that $Q_{\square}(P_{\Lambda})$ generates a P_{Ω} such that the last corner of Ω is a circle, so we have once again that $Q_{\circ} \circ Q_{\square}(P_{\Lambda}) = 0$ only if $\ell = N - k$ and $j = r$.

In summary, $Q_{\square} \circ Q_{\circ}(P_{\Lambda}) = 0$ and $Q_{\circ} \circ Q_{\square}(P_{\Lambda}) = 0$ iff: 1) all corners of Λ are circles, which are inner corners, except possibly for some circles that satisfy the conditions (ii) and (iii) of Lemma 4.3.10; or 2) the last corner of Λ is located in $(N - k, r)$ and all other corners of Λ are the upper corners of hooks type $B_{k,r}$, $\tilde{B}_{k,r}$, $C_{k,r}$ or $\tilde{C}_{k,r}$. \square

4.3.3 SPECIAL CASES OF INVARIANCE

The previous theorem clearly shows that for n , m , k , r , and N , the number of ways to construct superpartitions that lead to invariant polynomials could be enormous. In general such superpartitions do not have an explicit and compact form. There are two notable exceptions however: (1) when we are dealing with conventional partitions (no circle in the diagrams), which was studied by

Jolicoeur and Luque (see [37]), and (2) when the maximal length N of the superpartition is bounded as $N \leq 2k$. Below, we derive in a simple way one of their results, in the following corollary to 4.3.13. For the second case, we identify three simple forms of superpartitions associated with invariant polynomials.

Corollary 4.3.14. *Let $P_\lambda = P_\lambda(x_1, \dots, x_N; \alpha_{k,r})$, where λ is a (k, r, N) -admissible partition. The polynomial P_λ is invariant under translation if and only if*

$$\lambda = (((\beta + 1)r)^l, (\beta r)^k, \dots, r^k),$$

where $0 < \beta$, $0 \leq l \leq k$, and $N = k(\beta + 1) + l$.

Proof. As a consequence of Theorem 4.3.13, we have that P_λ is invariant under translation iff the last corner of λ 's diagram is located at position $(N - k, r)$ and all remaining corners are upper corners of hooks $B_{k,r}$. Thus, P_λ is invariant iff $\lambda = (((\beta + 1)r)^l, (\beta r)^k, \dots, r^k)$ with $0 < \beta$. The admissibility condition requires $0 \leq l \leq k$. Finally, the condition on the position for the last corner imposes $N = k(\beta + 1) + l$. \square

Corollary 4.3.15. *Assume (4.3.1), (4.3.2), and (4.3.3). Suppose moreover that Λ 's diagram contains m circles and that $N \leq 2k$. Then, P_Λ is invariant under translation if and only if Λ has one of the following forms:*

$$(F1) \quad \Lambda = (\emptyset; r^{N-k});$$

$$(F2) \quad \Lambda = (m - 1, m - 2, \dots, 1, 0; \emptyset), \text{ where } m \leq N \leq k \text{ or } N - 1 \geq k \geq N - m + r - 1$$

$$(F3) \quad \Lambda = (r + f - 1, r + f - 2, \dots, r - 1, g - 1, g - 2, \dots, 1, 0; r^{N-k-m}) \text{ where } m = f + g + 1, 0 \leq f \leq N - k - 1, 0 \leq g \leq \min(k, r - 1) \text{ and } f \geq g + N - 2k - 1.$$

These forms are respectively illustrated in Figures 4.2, 4.4, 4.5 below.

Proof. Let us start with the sufficient condition. According to Theorem 4.3.13, if Λ is of the form (F1), (F2) or (F3), then P_Λ is invariant under translation. Indeed, (F1) trivially satisfies (C1); the only corners in (F2) are inner circles, so

(F2) satisfies (C2); in (F3), all corners are inner circles, except one circle located at $(N - k, r)$, so it satisfies (C2) with $\bar{k} = 1$.

We now tackle the non-trivial part of the demonstration, which is the necessary condition. For this, let (ℓ, j) be the last corner of the Λ diagram. There are two obvious cases, depending on whether (ℓ, j) is an inner corner or not.

First, we suppose that (ℓ, j) is a bordering corner or an outer corner. According to Theorem 4.3.13, P_Λ is invariant under translation only if $N + 1 - \ell + \alpha_{k,r}(j - 1) = 0$, where $\alpha_{k,r} = -(k + 1)/(r - 1)$. Since $N + 1 - \ell > 0$, we must assume that $j - 1 = \bar{j}(r - 1)$, where \bar{j} is a positive integer. Then, the invariance condition requires $N = \ell + \bar{j}(k + 1) - 1$. However, by hypothesis, $N \leq 2k$, so $\bar{j} = 1$ (i.e., $j = r$). Therefore, the invariance condition and $N \leq 2k$ impose $j = r$ and $\ell = N - k \leq k$, which is compatible with the admissibility. Now, let (i, ℓ') be the first corner of Λ diagram. Once again, two cases are possible:

1. (i, ℓ') is a box. Suppose $(i, \ell') \neq (\ell, j)$. According to Theorem 4.3.13, P_Λ can be invariant only if we can form a hook $B_{k,r}$ or $\tilde{B}_{k,r}$ whose respective lengths are either $k + 1$ or $k + 2$, which is impossible because $\ell \leq k$. Then, the only possible squared corner is the last corner. Thus, the invariance and admissibility conditions impose that the diagram is made of $N - k$ rows with r boxes, corresponding to the first form of the proposition.
2. (i, ℓ') is a circle. Referring again to Theorem 4.3.13 and recalling that $\ell \leq k$, we see that P_Λ is invariant under translation only if $(i, \ell') = (\ell, j)$ or if (i, ℓ') is a inner circled corner. The first condition imposes $\Lambda = (r - 1; r^{N-k-1})$. The second imposes that only criterion (C2) can be considered, so all remaining corners must be circled inner corners. Consequently, $\Lambda = (r + m - 2, r + m - 3, \dots, r, r - 1; r^{N-k-m})$ for some $1 \leq m \leq N - k$. This is illustrated in Figure 4.3

Second, we suppose that (ℓ, j) is an inner corner. This implies that $j = 1$ and as a consequence, criterion (C1) of Theorem 4.3.13 cannot be satisfied. Thus, the only option is that the last corner is a circle and criterion (C2) must be satisfied: all other corners must be inner circles, except for at most one corner, which can be a bordering or outer circle, located at (\bar{i}, \bar{j}) , and such that $\bar{i} = N + 1 - \bar{k}(k + 1)$

Figure 4.2: Form (F1)

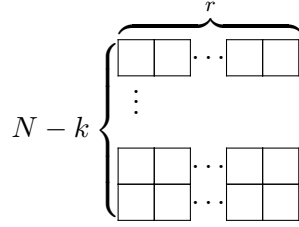
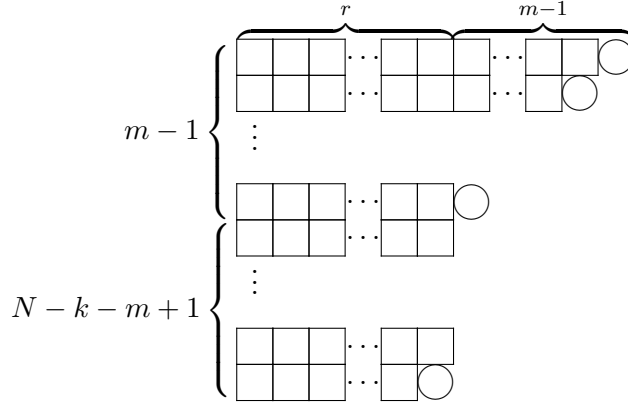

Figure 4.3: Form (F3) with $g = 0$



and $\bar{j} = \bar{k}(r-1)+1$ for some positive integer \bar{k} . However, we know that $\bar{i} < \ell \leq 2k$, so that $\bar{k} = 1$. In short, if (ℓ, j) is an inner corner, then all corners are inner circles, except for at most one non-inner corner, which could be a circle located at $(N - k, r)$. If all corners are inner ones, without exception, then the only possible superpartition is

$$\Lambda = (m - 1, m - 2, \dots, 1, 0; \emptyset), \quad m \leq N,$$

which is the form (F2) illustrated in Figure 4.4. Finally, if there is one exceptional corner, then all possible superpartitions can be written as

$$\Lambda = (r + f - 1, r + f - 2, \dots, r, r - 1, g - 1, g - 2, \dots, 0; r^{N-k-f}),$$

where

$$f + g + 1 = m, \quad g < r, \quad g \leq k, \quad f < N - k.$$

This is the last possible form and it is illustrated in Figure 4.5. Note that the admissibility imposes some additional restrictions on the forms (F2) and (F3). The form (F2) is admissible whenever $N \leq k$, while for $N > k$, it is admissible if $N + r - m - 1 \leq k$. In the case of (F3) (see Figure 4.5), the admissibility also requires $f \geq g + N - 2k - 1$.

Figure 4.4: Form (F2)

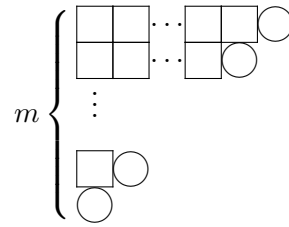
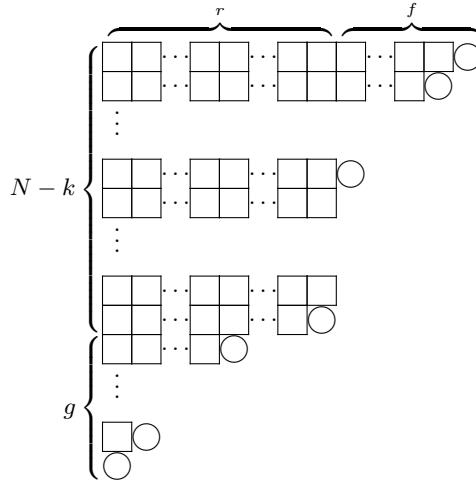

Figure 4.5: Form (F3)



We have demonstrated that only three forms of admissible superpartitions lead to invariant polynomials when $N \leq 2k$. □

4.4 THE CLUSTERING CONDITION FOR $k > 1$

Baratta and Forrester have shown that if symmetric Jack polynomials are also invariant under translation, then they almost automatically admit clusters [8]. In what follows, we generalize their approach to the case of Jack polynomials with prescribed symmetry.

Proposition 4.4.1. *Let $P_\Lambda(x_1, \dots, x_N; \alpha_{k,r})$ be a Jack polynomial with prescribed symmetry \mathcal{AS} , where Λ is as in (4.3.3) and of bi-degree $(n|m)$ and such that $N \geq k + m + 1$. Suppose moreover that Λ is such that $P_\Lambda(x_1, \dots, x_N; \alpha_{k,r})$ is translationally invariant.*

(i) *If $\ell(\Lambda) > N - k$ then*

$$P_\Lambda(x_1, \dots, x_N; \alpha_{k,r}) \Big|_{x_{N-k+1}=\dots=x_N=z} = 0.$$

(ii) *If $\ell(\Lambda) = N - k$ then*

$$P_\Lambda(x_1, \dots, x_N; \alpha_{k,r}) \Big|_{x_{N-k+1}=\dots=x_N=z} = \prod_{i=m+1}^{N-k} (x_i - z)^r Q(x_1, \dots, x_{N-k}, z)$$

for some polynomial Q of degree $n - (N - k - m)r$.

Proof. From the admissibility condition, we know that $P_\Lambda(x; \alpha_{k,r})$ is well defined. Moreover, the condition $N \geq k + m + 1$ ensures that the specialization of the k variables takes place in the set of variables in which P_Λ is symmetric. In other words, if α is not a negative rational nor zero, then

$$P_\Lambda(x; \alpha) \Big|_{x_{N-k+1}=\dots=x_N=z} \neq 0.$$

Thus, property (i) is not trivial. However, if we suppose that $P_\Lambda(x; \alpha_{k,r})$ is translationally invariant, then

$$P_\Lambda(x_1, \dots, x_N; \alpha_{k,r}) \Big|_{x_{N-k+1}=\dots=x_N=z} = P_\Lambda(x_1 - z, \dots, x_{N-k} - z, 0, \dots, 0; \alpha_{k,r}) \quad (4.4.1)$$

Now, by the stability property given in Lemma 2.4.6, the last equality can be rewritten as

$$P_\Lambda(x_1, \dots, x_N; \alpha_{k,r}) \Big|_{x_{N-k+1}=\dots=x_N=z} = P_\Lambda(x_1 - z, \dots, x_{N-k} - z; \alpha_{k,r}). \quad (4.4.2)$$

From this point, two cases are possible:

- (i) If $\ell(\Lambda) > N - k$, Lemma 2.4.6 also implies that the RHS of (4.4.2) is zero, as expected.
- (ii) If $\ell(\Lambda) = N - k$, then the RHS of (4.4.2) is not zero. From the triangularity property of the Jack polynomials with prescribed symmetry in the monomial basis, we can write

$$P_\Lambda(x_1 - z, \dots, x_{N-k} - z; \alpha_{k,r}) = m_\Lambda(x_1 - z, \dots, x_{N-k} - z) + \sum_{\Gamma < \Lambda} c_{\Lambda,\Gamma} m_\Gamma(x_1 - z, \dots, x_{N-k} - z).$$

Moreover, according to Theorem 4.3.13 and Lemma 4.3.11, the last corner in Λ 's diagram is located at $(N-k, r)$. This fact, together with $\ell(\Gamma) = N-k$ and $N \geq k + m + 1$, impose that

$$\Lambda_{N-k} \geq r \quad \text{and} \quad \Gamma_{N-k} \geq r \quad \text{for all } \Gamma < \Lambda.$$

Hence, $\prod_{i=m+1}^{N-k} (x_i - z)^r$ divides m_Γ for each m_Γ such that $\Gamma < \Lambda$. This finally implies that $\prod_{i=m+1}^{N-k} (x_i - z)^r$ divides $P_\Lambda(x_1 - z, \dots, x_{N-k} - z; \alpha_{k,r})$, and the proposition follows. □

The last proposition establishes the clustering properties conjectured in [26] in the case of translationally invariant polynomials. The next proposition shows that in this case, it is also possible to get more explicit clustering properties involving only Jack polynomials and not some indeterminate polynomials Q as before. Note that in some instances, we only form cluster of order $r - 1$. We stress that this is not in contradiction with the previous proposition. Indeed, more variables could be collected to get order r , but this factorization would not allow us to write explicit formulas in terms of Jack polynomials with prescribed symmetry.

To illustrate what was mentioned in the last paragraph, we consider the following examples, by taking $k = 3$, $r = 2$, $N = 7$, and $\alpha_{k,r} = -4$. It can be checked that:

- if $\Lambda = (2, 1, 0; 2, 2, 0, 0)$, then $P_\Lambda(x; \alpha_{k,r})$ is translationally invariant and moreover

$$P_\Lambda(x_1, x_2, \dots, x_7; \alpha_{k,r})|_{x_5=x_6=x_7=z} = 0$$

while

$$\begin{aligned} P_\Lambda(x_1, x_2, \dots, x_7; \alpha_{k,r})|_{x_3=x_6=x_7=z} &= (x_1-z)(x_2-z)(x_4-z)^2(x_5-z)^2(x_1-x_2) \\ &= \prod_{\substack{1 \leq i \leq 5 \\ i \neq 3}} (x_i - z) \cdot (x_1 - x_2)(x_4 - z)(x_5 - z) \\ &= \prod_{\substack{1 \leq i \leq 5 \\ i \neq 3}} (x_i - z) \cdot P_{\tilde{\Lambda}}(x_1 - z, x_2 - z, x_4 - z, x_5 - z) \end{aligned}$$

where $\tilde{\Lambda} = (1, 0; 1, 1)$.

- Now, if $\Lambda = (1; 3, 2, 2, 0, 0, 0)$, then $P_\Lambda(x; \alpha_{k,r})$ is translationally invariant and moreover

$$\begin{aligned} P_\Lambda(x_1, x_2, \dots, x_7; \alpha_{k,r})|_{x_5=x_6=x_7=z} &= -(x_1 - z)(x_2 - z)^2(x_3 - z)^2(x_4 - z)^2(3x_1 - x_2 - x_3 - x_4) \\ &= \prod_{1 \leq i \leq 4} (x_i - z) \cdot (x_2 - z)(x_3 - z)(x_4 - z)(3x_1 - x_2 - x_3 - x_4) \\ &= \prod_{1 \leq i \leq 4} (x_i - z) \cdot P_{\tilde{\Lambda}}(x_1 - z, x_2 - z, x_3 - z, x_4 - z) \end{aligned}$$

where $\tilde{\Lambda} = (0; 2, 1, 1)$.

Proposition 4.4.2. *Let $P_\Lambda(x_1, \dots, x_N)$ be a Jack polynomial with prescribed symmetry AS at $\alpha = \alpha_{k,r}$, where $\Lambda = (\Lambda_1, \dots, \Lambda_m; \Lambda_{m+1}, \dots, \Lambda_N)$ is as in (4.3.3) and of length $\ell \leq N$. Suppose that the partition $(\Lambda_{m+1}, \dots, \Lambda_N)$ contains f_0 parts equal to 0. Suppose moreover that Λ is such that $\Lambda_{N-f_0} = r$ and $P_\Lambda(x, \dots, x_N)$ is translationally invariant.*

(i) *If $\Lambda_m \geq r$ or $m = 0$, then*

$$P_\Lambda(x, \dots, x_N) \Big|_{x_{N-f_0+1}=\dots=x_N=z} = \prod_{i=1}^{N-f_0} (x_i - z)^r \cdot P_{\Lambda-r\ell}(x_1 - z, \dots, x_{N-f_0} - z).$$

(ii) If $\Lambda_m = r - 1$, then

$$P_\Lambda(x_1, \dots, x_N) \Big|_{x_{N-f_0+1}=\dots=x_N=z} = \prod_{i=1}^{N-f_0} (x_i - z)^{r-1} \cdot P_{\Lambda - (r-1)\ell}(x_1 - z, \dots, x_{N-f_0} - z).$$

(iii) If $\Lambda_m = 0$, then

$$\begin{aligned} & P_\Lambda(x_1, \dots, x_N) \Big|_{x_m=x_{N-f_0+1}=\dots=x_N=z} \\ &= \prod_{\substack{1 \leq i \leq N-f_0 \\ i \neq m}} (x_i - z)^v \cdot P_{\tilde{\Lambda}}(x_1 - z, \dots, x_{m-1} - z, x_{m+1} - z, \dots, x_{N-f_0} - z) \end{aligned}$$

where

$$v = \min(r, \Lambda_{m-1}), \quad \tilde{\Lambda} = \tilde{C}\Lambda - v^{(\ell-1)}, \quad \text{and} \quad \tilde{C}\Lambda = (\Lambda_1, \dots, \Lambda_{m-1}; \Lambda_{m+1}, \dots, \Lambda_N).$$

Proof. Proceeding as in the proof of the previous proposition, we use the translation invariance and the stability of the Jack polynomials with prescribed symmetry, and find

$$P_\Lambda(x_1, \dots, x_N) \Big|_{x_{N-f_0+1}=\dots=x_N=z} = P_\Lambda(x_1 - z, \dots, x_{N-f_0} - z). \quad (4.4.3)$$

(i) If $\Lambda_{N-f_0} = r$ and $m = 0$ or $m > 0$ and $\Lambda_m \geq r$, then we can decompose the superpartition Λ as

$$\Lambda = \tilde{\Lambda} + r^\ell,$$

where $\tilde{\Lambda}$ is some other superpartition, which could be empty, and r^ℓ denotes the partition (r, \dots, r) of length ℓ . This allows us to use Lemma 2.4.4 and factorize the RHS of (4.4.3). This yields, as expected,

$$P_\Lambda(x_1, \dots, x_N) \Big|_{x_{N-f_0+1}=\dots=x_N=z} = \prod_{i=1}^{N-f_0} (x_i - z)^r \cdot P_{\tilde{\Lambda}}(x_1 - z, \dots, x_{N-f_0} - z).$$

(ii) If $\Lambda_{N-f_0} = r$ and $\Lambda_m = r - 1$, then Λ can be decomposed as

$$\Lambda = \tilde{\Lambda} + (r - 1)^\ell,$$

where, this time, $\tilde{\Lambda}$ is a non-empty superpartition of length ℓ and such that $\tilde{\Lambda}_m = 0$. Using once again Lemma 2.4.4, we can factorize RHS of (4.4.3) and get the desired result:

$$P_\Lambda(x_1, \dots, x_N) \Big|_{x_{N-f_0+1}=\dots=x_N=z} = \prod_{i=1}^{N-f_0} (x_i - z)^{r-1} \cdot P_{\tilde{\Lambda}}^{(\alpha)}(x_1 - z, \dots, x_{N-f_0} - z).$$

(iii) Finally, we suppose $\Lambda_{N-f_0} = r$, $\Lambda_m = 0$, and $v = \min(r, \Lambda_{m-1})$. In equation (4.4.3), we set $x_m = z$. This yields

$$\begin{aligned} P_\Lambda(x_1, \dots, x_N) \Big|_{x_m=x_{N-f_0+1}=\dots=x_N=z} \\ = P_\Lambda(x_1 - z, \dots, x_{m-1} - z, 0, x_{m+1} - z, \dots, x_{N-f_0} - z). \end{aligned}$$

According to Lemma 2.4.8, the RHS of the last equation can be simplified as follows

$$\begin{aligned} P_\Lambda(x_1, \dots, x_N) \Big|_{x_m=x_{N-f_0+1}=\dots=x_N=z} \\ = P_{\tilde{C}\Lambda}(x_1 - z, \dots, x_{m-1} - z, x_{m+1} - z, \dots, x_{N-f_0} - z). \quad (4.4.4) \end{aligned}$$

Now, we can decompose $\tilde{C}\Lambda$ as

$$\tilde{C}\Lambda = \tilde{\Lambda} + v^{\ell-1},$$

for some superpartition $\tilde{\Lambda}$ whose length is smaller or equal to $\ell - 1$. This allows us to exploit Lemma 2.4.4 and rewrite the RHS of (4.4.4) as

$$\prod_{i=1}^{m-1} (x_i - z)^v \cdot \prod_{i=m+1}^{N-f_0} (x_i - z)^v \cdot P_{\tilde{\Lambda}}^{(\alpha)}(x_1 - z, \dots, x_{m-1} - z, x_{m+1} - z, \dots, x_{N-f_0} - z),$$

which is the desired result. \square

Let us consider a non-trivial example in relation with the last proposition. We choose $k = 2$, $r = 3$ and $N = 8$. Let $\Lambda = (8, 7, 5; 6, 3, 3)$, i.e.

$$\Lambda = \begin{array}{cccccccc} \square & \square & \square & \square & \square & \square & \square & \square & \circ \\ \square & \square & \square & \square & \square & \square & \square & \square & \circ \\ \square & \square & \square & \square & \square & \square & \square & \square & \circ \\ \square & \square & \square & \square & \square & \square & \square & \square & \\ \square & \square & \square & \square & \square & \square & \square & \square & \\ \square & \square & \square & \square & \square & \square & \square & \square & \\ \square & \square & \square & \square & \square & \square & \square & \square & \end{array}$$

Clearly $P_\Lambda(x; -3/2)$ is translationally invariant. Proposition 4.4.2 then yields

$$P_\Lambda(x_1, \dots, x_8; -3/2) \Big|_{x_7=x_8=z} = \prod_{i=4}^6 (x_i - z)^3 P_{\tilde{\Lambda}}^{(-3/2)}(x_1 - z, \dots, x_6 - z)$$

where $\tilde{\Lambda} = (5, 4, 2; 3)$, i.e.,

$$\tilde{\Lambda} = \begin{array}{cccccc} \square & \square & \square & \square & \square & \square & \circ \\ \square & \square & \square & \square & \square & \square & \circ \\ \square & \square & \square & \square & \square & \square & \circ \\ \square & \square & \square & \square & \square & \square & \circ \end{array}$$

Moreover, $P_{\tilde{\Lambda}}(x; -3/2)$ is also translationally invariant in $\tilde{N} = N - k = 6$ variables, so that

$$P_{\tilde{\Lambda}}(x_1 - z, \dots, x_6 - z; -3/2) = P_{\tilde{\Lambda}}(x_1, \dots, x_6; -3/2).$$

Therefore,

$$P_{\Lambda}(x_1, \dots, x_8; -3/2) \Big|_{x_7=x_8=z} = \prod_{i=4}^6 (x_i - z)^3 P_{\tilde{\Lambda}}(x_1, \dots, x_6; -3/2).$$

The last example is very special because it involves a pair of superpartitions satisfying the following bi-invariance property: Λ and $\tilde{\Lambda} = \Lambda - r^\ell$ are such that both $P_{\Lambda}(x_1, \dots, x_N; \alpha_{k,r})$ and $P_{\tilde{\Lambda}}(x_1, \dots, x_{N-k}; \alpha_{k,r})$ are invariant under translation. In fact, one can check that the diagrams given below define a large family of pairs of superpartitions satisfying this bi-invariance property. By using Theorem 4.3.13 we find sufficient conditions over Λ and $\tilde{\Lambda}$ that allow preserve the translation invariance of $P_{\Lambda}(x_1, \dots, x_N; \alpha_{k,r})$ and $P_{\tilde{\Lambda}}(x_1, \dots, x_{N-k}; \alpha_{k,r})$. These diagrams are shown below.

Figure 4.6: From left to right, the diagrams of Λ and $\tilde{\Lambda}$.

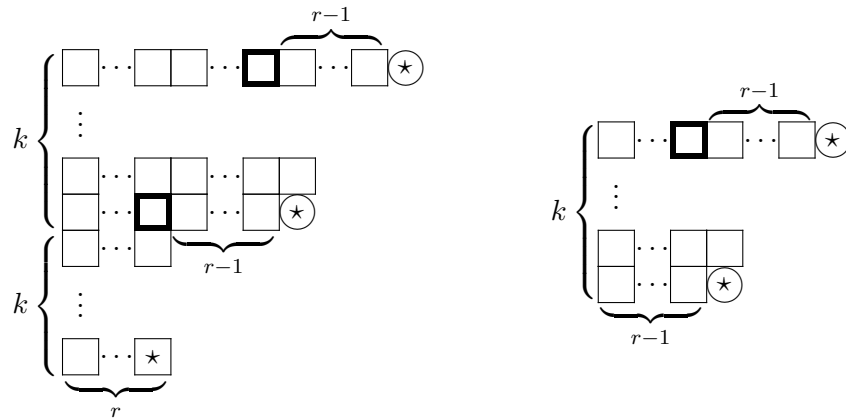

CHAPTER 5

MACDONALD POLYNOMIALS WITH PRESCRIBED SYMMETRY

In this final chapter we study the Macdonald polynomials with prescribed symmetry. Most of the results in this chapter are based on the fact that the Macdonald polynomials with prescribed symmetry can be expressed as a linear combination of non-symmetric Macdonald polynomials (see [1]). Following the scheme of the Jack polynomials with prescribed symmetry, we prove their stability and regularity properties. Also, since the Macdonald polynomials with prescribed symmetry are defined from the non-symmetric Macdonald polynomials, we use vanishing conditions for non-symmetric Macdonald polynomials (see [39]) to prove clustering properties for Macdonald polynomials with prescribed symmetry.

The results presented in this chapter about the Macdonald polynomials with prescribed symmetry have not yet been published.

5.1 NON-SYMMETRIC MACDONALD POLYNOMIALS

In this section, we introduce the non-symmetric Macdonald polynomials, which are a q -generalization of the non-symmetric Jack polynomials. After their definition, we recall their stability property, which will be used in the next section to prove the stability property of the Macdonald polynomial with symmetry AS or SS .

The non-symmetric Macdonald polynomials, like the non-symmetric Jack polynomials, can be defined in various ways. One way is to characterize them as triangular eigenfunctions of the Cherednik operators, through a combinatorial

formula (see [35]) and the other way is through a recursive formula (see [3]). In order to show the recursive formula, we introduce new operators. These operators are the q -analogues of the Dunkl operators, which were considered to define the non-symmetric Jack polynomials.

Let us first remark that the action of the q -shift operators, denoted by τ_i , on the function f in N -variables is given by

$$\tau_i f(x_1, \dots, x_i, \dots, x_N) = f(x_1, \dots, qx_i, \dots, x_N), \quad i = 1, \dots, N.$$

We need also to consider the Demazure-Lustig operators defined by

$$\begin{aligned} T_i &= t + \frac{tx_i - x_{i+1}}{x_i - x_{i+1}}(s_i - 1), \quad i = 1, \dots, N-1 \\ T_0 &= t + \frac{qtx_N - x_1}{qx_N - x_1}(s_0 - 1) \end{aligned}$$

where $s_i \in S_N$ is the transposition that exchanges i and $i+1$, which acts on the functions of N variables, through

$$s_i f(x_1, \dots, x_{i-1}, x_i, x_{i+1}, \dots, x_N) = f(x_1, \dots, x_{i-1}, x_{i+1}, x_i, \dots, x_N), \quad 1 \leq i \leq N-1 \quad (5.1.1)$$

and where $s_0 = s_{1N}\tau_1\tau_N^{-1}$, with s_{1N} such that $s_{1N}f(x_1, \dots, x_N) = f(x_N, \dots, x_1)$.

Also, we must define the ω operator,

$$\omega := s_{N-1} \dots s_2 s_1 \tau_1.$$

The above operators, T_i ($0 \leq i \leq N-1$) and ω satisfy the relations

$$\begin{aligned} (T_i - t)(T_i + 1) &= 0 \\ T_i T_{i+1} T_i &= T_{i+1} T_i T_{i+1} \\ T_i T_j &= T_j T_i \quad \text{if } |i - j| \geq 2 \\ \omega T_i &= T_{i-1} \omega. \end{aligned}$$

We can check that from the first relation, we get the identity $T_i^{-1} = t^{-1} - 1 + t^{-1}T_i$. Moreover, the operators T_i ($0 \leq i \leq N-1$) and ω generate the affine Hecke algebra.

In order to give the recursive definition, we must still introduce a new operator. It is the q -analogue of the raising operator Φ introduced by Knop and Sahi

in [47], and it is defined by

$$\Phi_q = x_N T_{N-1}^{-1} \dots T_2^{-1} T_1^{-1}.$$

It is sufficient to consider Φ_q and T_i operators to get the non-symmetric Macdonald polynomials. Baker and Forrester proved in [3, Corollary 4.2] that the operator Φ_q acts on non-symmetric Macdonald polynomials in the following manner

$$\Phi_q E_\eta(x; q, t) = t^{-\#\{\eta_i \geq \eta_1\}} E_{\Phi\eta}(x; q, t) \quad (5.1.2)$$

where $\Phi\eta := (\eta_2, \eta_3, \dots, \eta_N, \eta_1 + 1)$ (Φ is called the raising operator).

One important result in the theory of the non-symmetric Macdonald polynomials is the explicit action of the operator T_i ($\forall 1 \leq i < N - 1$) on E_η . It was shown in [56] that this action is given by

$$T_i E_\eta = \begin{cases} \frac{t-1}{1-\delta_{i,\eta}} E_\eta + t E_{s_i(\eta)}, & \eta_i < \eta_{i+1} \\ t E_\eta, & \eta_i = \eta_{i+1} \\ \frac{t-1}{1-\delta_{i,\eta}} E_\eta + \frac{(1-t\delta_{i,\eta})(1-t^{-1}\delta_{i,\eta})}{(1-\delta_{i,\eta})^2} E_{s_i(\eta)}, & \eta_i > \eta_{i+1}, \end{cases} \quad (5.1.3)$$

where $\delta_{i,\eta} = \bar{\eta}_i / \bar{\eta}_{i+1}$ and by abuse of notation, the operator that acts on compositions, called the switching operator is also denoted by s_i , and it is given by

$$s_i \eta = (\eta_1, \dots, \eta_{i-1}, \eta_{i+1}, \eta_i, \dots, \eta_N), \quad i = 1, \dots, N - 1.$$

Remark 5.1.1. *It is clear that all compositions can be recursively generated from the composition $(0, \dots, 0)$, by using s_i , the switching operator, and Φ the raising operator. Then, we can get the explicit expression for any non-symmetric Macdonald polynomial, using (5.1.2) and (5.1.3).*

Examples of non-symmetric Macdonald polynomials will be given in Appendix F.

As we have mentioned earlier, there are many ways to define the non-symmetric Macdonald polynomials. However, one of the most natural ways for us is to characterize them as triangular eigenfunctions of the q -analogues Dunkl operators.

These operators are defined as follows:

$$Y_i := t^{-N+i}T_i \dots T_{N-1}\omega T_1^{-1} \dots T_{i-1}^{-1}, \quad i = 1, \dots, N.$$

Let η be a composition and let q and t be formal parameters. Then, the non-symmetric Macdonald polynomial $E_\eta(x; q, t)$ is the unique polynomial satisfying

$$\begin{aligned} E_\eta(x; q, t) &= x^\eta + \sum_{\nu \prec \eta} b_{\eta\nu} x^\nu, \quad b_{\eta\nu} \in \mathbb{C}(q, t) \\ Y_i E_\eta(x; q, t) &= \bar{\eta}_i E_\eta(x; q, t) \quad 1 \leq i \leq N \end{aligned}$$

where

$$\bar{\eta}_i = q^{\eta_i} t^{-l'_\eta(i)} \quad \text{and} \quad l'_\eta(i) = \#\{k < i \mid \eta_k \geq \eta_i\} + \#\{k > i \mid \eta_k > \eta_i\}.$$

5.2 MACDONALD POLYNOMIALS WITH PRESCRIBED SYMMETRY

All along this section, we introduce the Macdonald polynomials with prescribed symmetry, which are built from the non-symmetric Macdonald polynomials by acting with the t -antisymmetrization and/or t -symmetrization operators defined on disjoint subsets of variables. Then, for each family of Macdonald polynomials with prescribed symmetry, we get a linear expansion in terms of non-symmetric Macdonald polynomials with explicit coefficients. Also, we show the stability property for two special families and the regularity property for each family of Macdonald polynomial with prescribed symmetry.

Before providing the precise definition of this type of polynomials, let us clarify what is meant by t -anti-symmetrization and t -symmetrization. A polynomial f is said t -antisymmetric with respect to x_i and x_{i+1} if $T_i f(x) = -f(x)$, it is t -symmetric with respect to the x_i and x_{i+1} if $T_i f(x) = t f(x)$. From this, we conclude that the t -symmetrization and t -anti-symmetrization operators are

$$U^+ = \sum_{\sigma \in S_N} T_\sigma, \quad \text{and} \quad U^- = \sum_{\sigma \in S_N} \left(\frac{-1}{t} \right)^{l(\sigma)} T_\sigma,$$

respectively. Let S_N denote the symmetric group acting on N -symbols. Note that if $\sigma = s_{i_{l(\sigma)}} \dots s_{i_1}$ where s_i are transposition operators as (5.1.1), then T_σ denotes the sequence of operators $T_{i_{l(\sigma)}} \dots T_{i_1}$.

The above t -symmetrization and t -antisymmetrization operators are closely related to the standard symmetrization and antisymmetrization operators, which are respectively defined as

$$S = \sum_{\sigma \in S_N} \sigma \quad \text{and} \quad A = \sum_{\sigma \in S_N} (-1)^{\ell(\sigma)} \sigma.$$

Indeed, one can show that for any polynomial f (see for instance [55]),

$$U^+ f(x) = \frac{A(\Delta_{t^{-1}} f(x))}{\Delta(x)} = S \left(\frac{\Delta_{t^{-1}}(x)}{\Delta(x)} f(x) \right) \quad (5.2.1)$$

and

$$U^- f(x) = \frac{\Delta_t(x)}{\Delta(x)} A f(x), \quad (5.2.2)$$

where

$$\Delta_t(x) := \prod_{1 \leq i < j \leq N} (x_i - t^{-1} x_j) \quad \text{and} \quad \Delta(x) := \prod_{1 \leq i < j \leq N} (x_i - x_j).$$

Definition 5.2.1. For a given positive integer $m \leq N$, set $I = \{1, \dots, m\}$ and $J = \{m+1, \dots, N\}$. Let $\lambda = (\lambda_1, \dots, \lambda_m)$ and $\mu = (\mu_1, \dots, \mu_{N-m})$ be partitions. The monic Macdonald polynomial with prescribed symmetry of type t -antisymmetric- t -symmetric (denoted AS) and indexed by the ordered set $\Lambda = (\lambda_1, \dots, \lambda_m; \mu_1, \dots, \mu_{N-m})$ is defined as follows

$$P_{\Lambda}^{\text{AS}}(x; q, t) = c_{\Lambda}^{\text{AS}} U_I^- U_J^+ E_{\eta}(x; q, t), \quad (5.2.3)$$

where η is a composition equal to $(\lambda_1, \dots, \lambda_m, \mu_1, \dots, \mu_{N-m})$ while the normalization factor c_{Λ}^{AS} is such that the coefficient of $x_1^{\lambda_1} \cdots x_m^{\lambda_m} x_{m+1}^{\mu_1} \cdots x_N^{\mu_{N-m}}$ in $P_{\Lambda}^{\text{AS}}(x; q, t)$ is equal to one. Other types of Macdonald polynomials are defined similarly:

$$\begin{aligned} P_{\Lambda}^{\text{AA}}(x; q, t) &= c_{\Lambda}^{\text{AA}} U_I^- U_J^- E_{\eta}(x; q, t), \\ P_{\Lambda}^{\text{SA}}(x; q, t) &= c_{\Lambda}^{\text{SA}} U_I^+ U_J^- E_{\eta}(x; q, t), \\ P_{\Lambda}^{\text{SS}}(x; q, t) &= c_{\Lambda}^{\text{SS}} U_I^+ U_J^+ E_{\eta}(x; q, t). \end{aligned}$$

We will introduce a new quantity associated to the composition's diagram.

Definition 5.2.2. For η a given composition, we denote

$$d_\eta := d_\eta(q, t) = \prod_{s \in \eta} (1 - q^{a_\eta(s)+1} t^{l_\eta(s)+1})$$

$$d'_\eta := d'_\eta(q, t) = \prod_{s \in \eta} (1 - q^{a_\eta(s)+1} t^{l_\eta(s)})$$

where a_η and l_η were given in (2.1.1).

In what follows, let

$$\lambda^+ = (\lambda_1, \dots, \lambda_m) \quad \text{and} \quad \mu^+ = (\mu_{m+1}, \dots, \mu_N)$$

denote partitions. As mentioned in previous chapters, we denote the composition obtained by the concatenation of λ^+ and μ^+ as follows:

$$\eta = (\lambda^+, \mu^+) \tag{5.2.4}$$

Also, a permutation of this composition means

$$\omega(\eta) = \gamma \tag{5.2.5}$$

where $\omega = \sigma \times \sigma'$ with $\sigma \in S_m$ and $\sigma' \in S_{N-m}$.

Proposition 5.2.3. Let $\eta = (\lambda^+, \mu^+)$ be a composition as in (5.2.4) and let Λ be its associated superpartition, i.e., $\varphi_m(\eta) = (\Lambda^*, \Lambda^\circledast)$. Then

$$P_\Lambda(x; q, t) = \sum_{\gamma = \omega(\eta)} \hat{c}_{\eta\gamma} E_\gamma(x; q, t) \tag{5.2.6}$$

where $\omega = \sigma \times \sigma'$ and $\sigma \in S_m$, $\sigma' \in S_{N-m}$. With

- i) $\hat{c}_{\eta\eta} = 1$ and $\hat{c}_{\eta\gamma} = \left(\frac{-1}{t}\right)^{\ell(\sigma)} \frac{d'_\eta d_\gamma}{d'_{(\lambda^+, \sigma'(\mu^+))} d_{(\lambda^+, \sigma'(\mu^+))}}$ if P_Λ is the type AS.
- ii) $\hat{c}_{\eta\eta} = 1$ and $\hat{c}_{\eta\gamma} = \left(\frac{-1}{t}\right)^{\ell(\sigma) + \ell(\sigma')} \frac{d_\gamma}{d_\eta}$ if P_Λ is the type AA.
- iii) $\hat{c}_{\eta\eta} = 1$ and $\hat{c}_{\eta\gamma} = \left(\frac{-1}{t}\right)^{\ell(\sigma')} \frac{d'_\eta d_\gamma}{d'_{(\sigma(\lambda^+), \mu^+)} d_{(\sigma(\lambda^+), \mu^+)}}$ if P_Λ is the type SA.
- iv) $\hat{c}_{\eta\eta} = 1$ and $\hat{c}_{\eta\gamma} = \frac{d'_\eta}{d'_\gamma}$ if P_Λ is the type SS.

Proof. Cases ii) and iii) were proved in [1] (see Corollary 1). Since all cases can be proved in a similar way, we only give the proof for the case i).

First note that we can write

$$\sum_{\gamma=\omega(\eta)} \hat{c}_{\eta\gamma} E_\gamma(x; q, t) = \sum_{\substack{\gamma=\omega(\eta) \\ \gamma_i \leq \gamma_{i+1}}} \chi_{i,i+1} (\hat{c}_{\eta\gamma} E_\gamma(x; q, t) + \hat{c}_{\eta s_i(\gamma)} E_{s_i(\gamma)}(x; q, t)) \quad (5.2.7)$$

where $\chi_{i,i+1} = \frac{1}{2}$ if $\gamma_i = \gamma_{i+1}$ and $\chi_{i,i+1} = 1$ if $\gamma_i < \gamma_{i+1}$.

If we consider $i \in I$, we just have the possibility $\gamma_i < \gamma_{i+1}$. In this case, we have, on the one hand,

$$T_i P_\Lambda(x; q, t) = -P_\Lambda(x; q, t)$$

and, on the other hand,

$$T_i(\hat{c}_{\eta\gamma} E_\gamma + \hat{c}_{\eta s_i(\gamma)} E_{s_i(\gamma)}) = \hat{c}_{\eta\gamma} T_i E_\gamma + \hat{c}_{\eta s_i(\gamma)} T_i E_{s_i(\gamma)}.$$

Now, by using the first and third line of relation (5.1.3), and then ordering the terms, we obtain

$$\begin{aligned} T_i(\hat{c}_{\eta\gamma} E_\gamma + \hat{c}_{\eta s_i(\gamma)} E_{s_i(\gamma)}) &= \left(\hat{c}_{\eta\gamma} \frac{t-1}{1-\delta_{i,\eta}^{-1}} + \hat{c}_{\eta s_i(\gamma)} \frac{(1-t\delta_{i,s_i(\gamma)})(1-t^{-1}\delta_{i,s_i(\gamma)})}{(1-\delta_{i,s_i(\gamma)})^2} \right) E_\gamma \\ &\quad + \left(\hat{c}_{\eta\gamma} t + \hat{c}_{\eta s_i(\gamma)} \frac{t-1}{1-\delta_{i,s_i(\gamma)}^{-1}} \right) E_{s_i(\gamma)} \quad (5.2.8) \end{aligned}$$

then, by comparing the coefficients and using that $\gamma_i < \gamma_{i+1}$, we get the equality $\delta_{i,s_i(\gamma)} = \delta_{i,\gamma}^{-1}$, which implies

$$\frac{\hat{c}_{\eta\gamma}}{\hat{c}_{\eta s_i(\gamma)}} = \frac{-(t-\delta_{i,\gamma})}{t(1-\delta_{i,\gamma})} \quad \forall i \in I. \quad (5.2.9)$$

Since $\gamma_i < \gamma_{i+1}$ we can use equation (19) of [7] to rewrite (5.2.9) and thus

$$\frac{\hat{c}_{\eta\gamma}}{\hat{c}_{\eta s_i(\gamma)}} = \frac{-1}{t} \frac{d_\gamma}{d_{s_i(\gamma)}}. \quad (5.2.10)$$

Now, by noting that $\lambda^+ = \sigma^{-1}(\gamma) = s_{i_1} \dots s_{i_{\ell(\sigma)}}(\gamma)$ for some $s_i \in S_m$, and applying (5.2.10) repeatedly, we obtain

$$\frac{\hat{c}_{\eta\gamma}}{\hat{c}_{\eta(\lambda^+, \sigma'(\mu^+)})} = \left(\frac{-1}{t} \right)^{\ell(\sigma)} \frac{d_\gamma}{d_{(\lambda^+, \sigma'(\mu^+)})}. \quad (5.2.11)$$

On the other hand, we know that $T_j P_\Lambda(x; q, t) = t P_\Lambda(x; q, t)$ if $j \in J$. Note that if $\gamma_j = \gamma_{j+1}$ then $T_j E_\gamma = t E_\gamma$ holds true due to the second line of (5.1.3). Hence, we consider the case $\gamma_j < \gamma_{j+1}$. In this case we have the expansion given in (5.2.8), and by using the above arguments, we get

$$\frac{\hat{c}_{\eta\gamma}}{\hat{c}_{\eta s_j(\gamma)}} = \frac{(t\delta_{j,\gamma} - 1)}{t(\delta_{j,\gamma} - 1)} \quad \forall j \in J. \quad (5.2.12)$$

Since $\gamma_j < \gamma_{j+1}$ we can use equation (19) of [7] to rewrite (5.2.12) and thus

$$\frac{\hat{c}_{\eta\gamma}}{\hat{c}_{\eta s_j(\gamma)}} = \frac{d'_{s_j(\gamma)}}{d'_\gamma}. \quad (5.2.13)$$

Once again, by noting that $\mu^+ = \sigma'^{-1}(\gamma) = s_{j_1} \dots s_{j_{\ell(\sigma')}}(\gamma)$ for some $s_j \in S_{N-m}$, and applying (5.2.13) repeatedly, we obtain

$$\frac{\hat{c}_{\eta(\lambda^+, \sigma'(\mu^+))}}{\hat{c}_{\eta\mu}} = \hat{c}_{\eta(\lambda^+, \sigma'(\mu^+))} = \frac{d'_\eta}{d'_{(\lambda^+, \sigma'(\mu^+))}}. \quad (5.2.14)$$

Finally, equations (5.2.11) and (5.2.14) imply the result. \square

We prove the stability property for the Macdonald polynomials with prescribed symmetry of type AS and SS, by making use of the stability property of the non-symmetric Macdonald polynomials with respect to the number of variables (see [55, equation (3.2)]). To be more precise, let $\eta = (\eta_1, \dots, \eta_N)$ and $\eta_- = (\eta_1, \dots, \eta_{N-1})$ be compositions. Then,

$$E_\eta(x_1, \dots, x_{N-1}, 0; q, t) = \begin{cases} E_{\eta_-}(x_1, \dots, x_{N-1}; q, t), & \text{if } \eta_N = 0, \\ 0 & \text{if } \eta_N > 0. \end{cases} \quad (5.2.15)$$

Proposition 5.2.4 (Stability for types AS and SS). *Let*

$\Lambda = (\Lambda_1, \dots, \Lambda_m; \Lambda_{m+1}, \dots, \Lambda_N)$ *be a superpartition and let*

$\Lambda_- = (\Lambda_1, \dots, \Lambda_m; \Lambda_{m+1}, \dots, \Lambda_{N-1})$. *Then, the Macdonald polynomial with prescribed symmetry AS or SS satisfies*

$$P_\Lambda(x_1, \dots, x_N; q, t)|_{x_N=0} = \begin{cases} P_{\Lambda_-}(x_1, \dots, x_{N-1}; q, t), & \text{if } \Lambda_N = 0 \\ 0, & \text{if } \Lambda_N > 0. \end{cases} \quad (5.2.16)$$

Proof. The cases AS and SS being similar, we only give the proof for AS.

We denote $\eta = (\lambda, \mu)$ to the composition formed by the concatenation of the partitions $\lambda = (\Lambda_1, \dots, \Lambda_m)$ and $\mu = (\Lambda_{m+1}, \dots, \Lambda_N)$. Notice that η is a composition like (5.2.4) and its associated superpartition is Λ . Now, Proposition (5.2.6) allows to obtain the expansion of a Macdonald with prescribed symmetry in terms of the non-symmetric Macdonald polynomials. Then, if we evaluate $x_N = 0$ we have

$$P_\Lambda(x_1, \dots, x_{N-1}, 0; q, t) = \sum_{\gamma=\omega(\eta)} \hat{c}_{\eta\gamma} E_\gamma(x_1, \dots, x_{N-1}, 0; q, t) \quad (5.2.17)$$

where $\omega = \sigma \times \sigma'$ and $\sigma \in S_m$, $\sigma' \in S_{N-m}$.

By making use of the stability property of non-symmetric Macdonald polynomials (see equation (5.2.15)), we conclude that in the above equality, the only summands that are not zero are those whose composition has the form $\gamma = (\bar{\omega}(\eta_-), 0)$, where $\eta_- = (\lambda, \mu_-, 0) = (\Lambda_1, \dots, \Lambda_m, \Lambda_{m+1}, \dots, \Lambda_{N-1}, 0)$, $\bar{\omega} = \sigma \times \bar{\sigma}$ with $\sigma \in S_m$, and $\bar{\sigma} \in S_{N-m-1}$. Furthermore, it is verified that for each γ we have

$$\frac{d'_{(\eta_-, 0)} d_{(\bar{\omega}(\eta_-), 0)}}{d'_{(\lambda, \bar{\sigma}(\mu_-), 0)} d_{(\lambda, \bar{\sigma}(\mu_-), 0)}} = \frac{d'_{(\eta_-)} d_{(\bar{\omega}(\eta_-))}}{d'_{(\lambda, \bar{\sigma}(\mu_-))} d_{(\lambda, \bar{\sigma}(\mu_-))}}.$$

Thus, we can rewrite the equality (5.2.17) as follows

$$P_\Lambda(x_1, \dots, x_{N-1}, 0; q, t) = \sum_{\gamma_-=\bar{\omega}(\eta_-)} \hat{c}_{\eta\gamma_-} E_{\gamma_-}(x_1, \dots, x_{N-1}; q, t),$$

and the proposition follows. \square

As mentioned in the Introduction, the regularity is not obvious for all possible specializations of q and t . Nevertheless, we give a sufficient condition that allows to preserve this property. This result is used at the end of the chapter to prove the clustering properties for $k = 1$ of the Macdonald polynomials with prescribed symmetry.

Proposition 5.2.5 (Regularity at $q^{r-1} = t^{-(k+1)}$). *Let Λ be a (k, r, N) -admissible superpartition. Then, $P_\Lambda(x; q, t)$ is regular under the specialization $t^{k+1}q^{r-1} = 1$.*

Proof. The proof follows from Proposition 5.2.3 and the explicit formulas for the coefficients given in (5.2.6). All cases are similar. The only differences are

the type of admissibility for each symmetry type and the explicit formula of the coefficients. Hence, we restrict our proof to the symmetry type AS.

Let $\eta = (\lambda^+, \mu^+)$ be the associated composition to Λ , i.e., $\varphi_m(\eta) = \Lambda$. According to Proposition (5.2.3), we have

$$P_\Lambda(x; q, t) = \sum_{\gamma=\omega(\eta)} \hat{c}_{\eta\gamma} E_\gamma(x; q, t). \quad (5.2.18)$$

Then, if we wish to prove that $P_\Lambda(x; q, t)$ is regular under the specialization $t^{k+1}q^{r-1} = 1$, it is sufficient to prove that for each $\gamma = \omega(\eta)$ the summand $\hat{c}_{\eta\gamma} E_\gamma(x; q, t)$ has not pole at $t^{k+1}q^{r-1} = 1$.

Let $\xi_\lambda := \prod_{s \in \lambda} (1 - q^{a(s)+1} t^{l(s)+1}) E_\lambda$. By Corollary (5.2) of [46] we know that $\xi_\lambda = \sum_\mu c_{\lambda\mu} x^\mu$ where $c_{\lambda\mu} \in \mathbb{Z}[q, t]$. Now, since in the expansion (5.2.18) each non-symmetric Macdonald polynomial $E_\gamma(x; q, t)$ is multiplied by its respective coefficient d_γ , and this implies $d_\gamma E_\gamma(x; q, t) \in \mathbb{Z}[q, t][x]$.

Then, to prove that $P_\Lambda(x; q, t)$ is regular, we just have to show for each composition γ in the expansion (5.2.18) the coefficients d'_η , $d'_{(\lambda^+, \sigma'(\mu^+))}$ and $d_{(\lambda^+, \sigma'(\mu^+))}$ are not zero.

We proceed in two main steps. First, following the idea used in Lemma 3.2.1, we obtain the expression of d'_η in terms of the associated superpartition to η :

$$d'_\eta(q, t) = \prod_{s \in BF(\Lambda)} (1 - q^{a_{\Lambda^*}(s)+1} t^{l_{\Lambda^*}(s)}) \prod_{s \in \Lambda^*/BF(\Lambda)} (1 - q^{a_{\Lambda^*}(s)+1} t^{l_{\Lambda^*}(s)}).$$

Now, the observation of (5.3.2) infers that $d'_\eta(q, t) = 0$ iff there exist a $\rho \in \mathbb{Z}_+$ satisfying one of the two following conditions:

- i) For some $s \in BF(\Lambda)$, we have $a_{\Lambda^*}(s) + 1 = \rho(r - 1)$ and $l_{\Lambda^*}(s) = \rho(k + 1)$.

Using both relations and expressing them in terms of the components of Λ , we get

$$\Lambda_i^* - \Lambda_{i+\rho(k+1)}^\otimes \leq \rho(r - 1) - 1.$$

As we assume that s belongs to some bosonic row, then $\Lambda_i^* = \Lambda_i^\otimes$. Thus, the last equality can be rewritten as

$$\rho(r - 1) - 1 \geq \Lambda_i^\otimes - \Lambda_{i+\rho(k+1)}^\otimes.$$

However, Lemma 3.1.2 implies that $\Lambda_i^\otimes - \Lambda_{i+\rho(k+1)}^\otimes \geq \Lambda_i^\otimes - \Lambda_{i+\rho(k+1)-1}^\otimes \geq \rho r$. Hence, $\rho(r - 1) - 1 \geq \Lambda_i^\otimes - \Lambda_{i+\rho(k+1)}^\otimes \geq \rho r$, which is a contradiction.

- ii) For some $s \in \Lambda^*/BF(\Lambda)$ we have $a_{\Lambda^*}(s)+1 = \rho(r-1)$ and $l_{\Lambda^*}(s) = \rho(k+1)$. Using both relations and expressing them in terms of the components of Λ , we get

$$\rho(r-1) - 1 \geq \Lambda_i^* - \Lambda_{i+\rho(k+1)}^*$$

and since $\Lambda_i^{\otimes} \leq \Lambda_i^* + 1$ we can rewrite the last equality as

$$\rho(r-1) \geq \Lambda_i^{\otimes} - \Lambda_{i+\rho(k+1)}^*.$$

But we know that $\Lambda_i^{\otimes} - \Lambda_{i+\rho(k+1)}^* \geq \Lambda_i^{\otimes} - \Lambda_{i+\rho(k+1)-1}^*$. By Lemma 3.1.2, we have $\Lambda_i^{\otimes} - \Lambda_{i+\rho(k+1)-1}^* \geq \rho r$, obtaining a contradiction.

Therefore, whenever we have the specialization $t^{k+1}q^{r-1} = 1$ and Λ is a weakly (k, r, N) admissible superpartition, we conclude that $d'_{\eta}(q, t) \neq 0$. Following a similar argument, we conclude that $d_{\eta}(q, t) \neq 0$.

Second, we must show that the coefficients $d'_{(\lambda^+, \sigma'(\mu^+))}$ and $d_{(\lambda^+, \sigma'(\mu^+))}$ are not zero. We introduce a new parameter δ taking the values 0 or 1, in order to consider both cases, $d'_{(\lambda^+, \sigma'(\mu^+))}$ and $d_{(\lambda^+, \sigma'(\mu^+))}$ simultaneously. We analyze separately two possible cases:

- i) s' is a cell such that s' belongs to a fermionic row. In this case, we have that $d'_{(\lambda^+, \sigma'(\mu^+))}(s') = d'_{\eta}(s')$ (analogously $d_{(\lambda^+, \sigma'(\mu^+))}(s') = d_{\eta}(s')$). Then, by using the result obtained in first step, we conclude $d'_{(\lambda^+, \sigma'(\mu^+))}(s') \neq 0$ and $d_{(\lambda^+, \sigma'(\mu^+))}(s') \neq 0$, as expected.
- ii) s' belongs to a bosonic row. Suppose first that $s' = (i', j')$ is such that $j' > 1$. Let $s \in \Lambda$ the associated cell to s' . Then, we have $l_{(\lambda^+, \sigma'(\mu^+))}(s') = l_{\Lambda^*}(s) - \epsilon$ for some $\epsilon \geq 0$ and where $s = (i, j' - 1)$. Thus, $d'_{(\lambda^+, \sigma'(\mu^+))}(s') = 0$ (respectively $d_{(\lambda^+, \sigma'(\mu^+))}(s') = 0$) iff $a_{\Lambda^*}(s) + 1 = \rho(r-1)$ and $l_{\Lambda^*}(s) + \delta - \epsilon = \rho(k+1)$ (considering $\delta = 0$ for the product d' and $\delta = 1$ for d). We can rewrite the above relations as follows

$$\Lambda_i^* - \Lambda_{i+\rho(k+1)+\epsilon-\delta}^* \leq \rho(r-1).$$

Moreover, we have by assumption, $\Lambda_i^{\otimes} = \Lambda_i^*$ (bosonic row), so that the previous line can be rewritten as

$$\Lambda_i^{\otimes} - \Lambda_{i+\rho(k+1)+\epsilon-\delta}^* \leq \rho(r-1)$$

but, obviously we have that $\Lambda_i^\circledast - \Lambda_{i+\rho(k+1)+\epsilon-\delta}^* \geq \Lambda_i^\circledast - \Lambda_{i+\rho(k+1)-\delta}^*$. Combining these equations, we get $\rho(r-1) \geq \Lambda_i^\circledast - \Lambda_{i+\rho(k+1)-\delta}^*$, which is a contradiction with the admissibility condition of Λ (see Lemma 3.1.2).

Finally, we must consider the cells $s' = (i', 1)$ such that s' belong to a bosonic row. Once again, we let $s \in \Lambda$ be the cell associated to s' . Let also $\alpha = \#\{k < i | \eta_k = 0\}$ and $\beta = \#\{k > i | \eta_k = 0\}$. Then,

$$l_{(\lambda^+, \sigma'(\mu^+))}(s') = l_{\Lambda^*}(s) + \alpha \quad \text{and} \quad N = i + l_{\Lambda^*}(s) + \alpha + \beta. \quad (5.2.19)$$

However, we know that $d'_{(\lambda^+, \sigma'(\mu^+))} = 0$ ($d_{(\lambda^+, \sigma'(\mu^+))} = 0$) iff there exist $\rho \in \mathbb{Z}_+$ such that

$$a_{(\lambda^+, \sigma'(\mu^+))}(s') + 1 = \rho(r-1) \quad \text{and} \quad l_{(\lambda^+, \sigma'(\mu^+))}(s') + \delta = \rho(k+1). \quad (5.2.20)$$

On the one hand, combining the conditions given in (5.2.20) and the assumption $s' = (i', 1)$, we get $\Lambda_i^* = \rho(r-1)$. And on the other hand, combining (5.2.19) and (5.2.20) we obtain $i = N - \rho(k+1) + \delta - \beta$. Thus, $\Lambda_i^* \geq \Lambda_{N-\rho(k+1)+\delta}^*$. However, by Lemma 3.1.2 we have $\Lambda_{N-\rho(k+1)+\delta}^\circledast - \Lambda_N^* \geq \rho r$, which implies $\Lambda_{N-\rho(k+1)+\delta}^* \geq \rho r - 1$. We have therefore shown that $\rho(r-1) = \Lambda_i^* \geq \Lambda_{N-\rho(k+1)+\delta}^* \geq \rho r - 1$, concluding that the only possible case is $\rho = 1$. Now, if $\rho = 1$, we have $\Lambda_i^\circledast = \Lambda_i^* = r-1$ with $i \leq N-k$, which is clearly in contradiction with the admissibility condition of Λ . Therefore, we conclude that $d'_{(\lambda^+, \sigma'(\mu^+))}$ and $d_{(\lambda^+, \sigma'(\mu^+))}$ are not zero, as expected.

From the first and second steps, we conclude that the coefficient $\frac{d'_\eta}{d'_{(\lambda^+, \sigma'(\mu^+))} d_{(\lambda^+, \sigma'(\mu^+))}}$ has no zeros or poles at the specialization $t^{k+1}q^{r-1} = 1$ when Λ is a weakly (k, r, N) admissible superpartition. Hence the proposition follows. \square

5.3 CLUSTERING PROPERTIES

In this section we study briefly the clustering properties of the Macdonald polynomials with prescribed symmetry. To this end, we consider two cases: $k = 1$ and $k > 1$. In the first case, we get the desired result, i.e. we obtain a factorization where the degree expected is reached. However, for the case $k > 1$, we

conjecture the general cluster property, but we can only show that the degree reached is the degree expected minus 1.

All results of this section are based on the results of Kasatani (see [39]), which deal with vanishing conditions for non-symmetric Macdonald polynomials, and which are enunciated in the following subsection.

5.3.1 ZEROS OF THE NON-SYMMETRIC MACDONALD POLYNOMIALS

In this subsection, we summary some results of Kasatani [39], which are relevant for our work.

We assume the specialization of the parameters at $t^{k+1}q^{r-1} = 1$ for $1 \leq k \leq n-1$ and $r \geq 2$. Also, we introduce a new parameter u and we specialize according to the new notation. Let M be the greatest common divisor of $(k+1, r-1)$ and ω an M -th primitive root of the unity and $\omega_1 \in \mathbb{C}$ such that $\omega_1^{(r-1)/M} = \omega$. For the new indeterminate u , we consider the specialization

$$t = u^{\frac{r-1}{M}}, \quad q = \omega_1 u^{-\frac{k+1}{M}} \quad (5.3.1)$$

such that $t^{\frac{k+1}{M}} q^{\frac{r-1}{M}} = \omega$ and $t^{k+1}q^{r-1} = 1$.

Remark 5.3.1. *Given $a, b \in \mathbb{Z}$ we have*

$$q^a t^b = 1 \quad \text{iff} \quad a = (r-1)s, \quad \text{and} \quad b = (k+1)s \quad \text{for some } s \in \mathbb{Z}. \quad (5.3.2)$$

Definition 5.3.2 (Wheel condition). *A polynomial f satisfies the (k, r, N) wheel condition whenever*

$$f(x_1, \dots, x_N) = 0 \quad \text{if} \quad x_{i_{a+1}} = x_{i_a} t q^{s_a} \quad (1 \leq a \leq k) \quad (5.3.3)$$

for all non-negative integers $i_1, \dots, i_{k+1}, s_1, \dots, s_k$ such that

$$\text{all } i_a \text{ are distinct, } \sum_{a=1}^k s_a \leq r-2, \quad \text{and} \quad i_a < i_{a+1} \text{ if } s_a = 0.$$

We denote by $I_N^{(k,r)}$ the space of polynomials satisfying the wheel condition (5.3.3).

Definition 5.3.3 (Admissible compositions). *The composition $\lambda \in \mathbb{N}_0^N$ is (k, r, N) -admissible if*

$$\lambda_{i_a} - \lambda_{i_{a+k}} \geq r \quad \text{or} \quad \lambda_{i_a} - \lambda_{i_{a+k}} = r - 1 \quad \text{and} \quad i_a < i_{a+k} \quad (1 \leq a \leq n - k), \quad (5.3.4)$$

where the indices $(i_1, \dots, i_n) = \omega \cdot (1, \dots, n)$ are so chosen that ω is the shortest element of S_N such that $\lambda = \omega \cdot \lambda^+$. We define the set $B_N^{(k,r)}$ as the set of all compositions λ that satisfy (5.3.4).

Theorem 5.3.4. [39, Theorem (3.11)] *For any $\lambda \in B_N^{(k,r)}$, the non-symmetric Macdonald polynomial E_λ has no pole at (5.3.1). Moreover, a basis of the ideal $I_N^{(k,r)}$ is given by $\{E_\lambda | \lambda \in B_N^{(k,r)}\}$ specialized at (5.3.1).*

5.3.2 CLUSTERING PROPERTIES FOR $k = 1$

We start this subsection by showing the explicit factorization of the non-symmetric Macdonald polynomial indexed by a staircase partition at the specialization $q^{r-1} = t^{-2}$ (with r even). Then, we show the general cluster when $k = 1$ and when the polynomial is indexed by an $(1, r, N)$ -admissible superpartition. This result is proved for each family of Macdonald polynomials with prescribed symmetry (AS, AA, SA and SS). And, in particular for the Macdonald polynomial with prescribed symmetry of type AS, we get explicit formulas for special staircases superpartitions.

Corollary 5.3.5. *Let $k = 1$, r be positive and even and denote $\alpha_{1,r} = -\frac{2}{r-1}$. Then*

$$E_{(r-1)\delta_N}(x_1, \dots, x_N; t^{-2/(r-1)}, t) = \prod_{1 \leq i < j \leq N} \prod_{0 \leq s \leq r-2} (x_i - t^{-s\alpha_{1,r}-1} x_j). \quad (5.3.5)$$

Proof. It is clear that the partition $(r-1)\delta_N$ belongs to Kasatani's set $B^{(1,r)}$, so by using Theorem 5.3.4 we get that $E_{(r-1)\delta_N}(x_1, \dots, x_N; t^{-2/(r-1)}, t)$ is divisible by the product of the factors on the right side of equation (5.3.5). Then, by comparing the degree of both polynomials we get the result. \square

Theorem 5.3.6. *Let $k = 1$, r be positive and even and denote $\alpha_{1,r} = -\frac{2}{r-1}$. Let also Λ be a superpartition of bi-degree $(n|m)$ with $\ell(\Lambda) \leq N$. If Λ is strict and weakly $(1, r, N)$ -admissible, then*

i)

$$P_{\Lambda}^{\text{AS}}(x_1, \dots, x_N; t^{-2/(r-1)}, t) = \prod_{1 \leq i < j \leq N} \prod_{0 \leq s \leq r-2} (x_i - t^{-s\alpha_{1,r-1}} x_j) \\ \times \prod_{m+1 \leq i < j \leq N} (x_i - t x_j) Q(x)$$

$$ii) P_{\Lambda}^{\text{AA}}(x_1, \dots, x_N; t^{-2/(r-1)}, t) = \prod_{1 \leq i < j \leq N} \prod_{0 \leq s \leq r-2} (x_i - t^{-s\alpha_{1,r-1}} x_j) Q(x).$$

In the above equations, $Q(x_1, \dots, x_N)$ denotes some polynomial, which varies from one symmetry type to another.

Proof. The cases AS and AA being similar, we only give the proof for AS. Moreover, during this proof we write P_{Λ} instead of P_{Λ}^{AS} and let $I := \{1, \dots, m\}$ and $J := \{m+1, \dots, N\}$.

Let η be the associated composition to Λ , i.e., $\varphi_m(\eta) = \Lambda$. We can prove easily that if Λ is weakly $(1, r, N)$ -admissible, then η belongs to $B^{(1,r)}$. This implies that $E_{\eta}(x; q, t)|_{q=t^{-2/(r-1)}}$ is divisible by $\prod_{1 \leq i < j \leq N} \prod_{0 \leq s \leq r-2} (x_i - t^{-s\alpha_{1,r-1}} x_j)$. Thus, there exists a polynomial $f(x)$ in $\mathbb{C}(t)[x]$ such that

$$E_{\eta}(x; q, t)|_{q=t^{-2/(r-1)}} = \prod_{1 \leq i < j \leq N} \prod_{0 \leq s \leq r-2} (x_i - t^{-s\alpha_{1,r-1}} x_j) f(x_1, \dots, x_N).$$

Now, since $P_{\Lambda}(x_1, \dots, x_N; t^{-2/(r-1)}, t) = U_I^- U_J^+ E_{\eta}(x; q, t)|_{q=t^{-2/(r-1)}}$, we get

$$P_{\Lambda}(x_1, \dots, x_N; t^{-2/(r-1)}, t) \\ = U_I^- U_J^+ \left(\prod_{1 \leq i < j \leq N} \prod_{0 \leq s \leq r-2} (x_i - t^{-s\alpha_{1,r-1}} x_j) f(x_1, \dots, x_N) \right) \\ = U_I^- \left(\prod_{1 \leq i < j \leq m} \prod_{0 \leq s \leq r-2} (x_i - t^{-s\alpha_{1,r-1}} x_j) \right) \\ \times U_J^+ \left(\prod_{i=1}^m \prod_{j=m+1}^N \prod_{0 \leq s \leq r-2} (x_i - t^{-s\alpha_{1,r-1}} x_j) \right) \\ \times \left(\prod_{m+1 \leq i < j \leq N} \prod_{0 \leq s \leq r-2} (x_i - t^{-s\alpha_{1,r-1}} x_j) f(x_1, \dots, x_N) \right). \quad (5.3.6)$$

However, formula (5.2.1) allows to express U_J^+ in terms of the symmetrization operator acting on the last $N - m$ variables, and so we have

$$\begin{aligned}
& U_J^+ \left(\prod_{i=1}^m \prod_{j=m+1}^N \prod_{0 \leq s \leq r-2} (x_i - t^{-s\alpha_{1,r-1}} x_j) \right. \\
& \quad \times \left. \prod_{m+1 \leq i < j \leq N} \prod_{0 \leq s \leq r-2} (x_i - t^{-s\alpha_{1,r-1}} x_j) f(x_1, \dots, x_N) \right) \\
& = S_J \left(\prod_{i=1}^m \prod_{j=m+1}^N \prod_{0 \leq s \leq r-2} (x_i - t^{-s\alpha_{1,r-1}} x_j) \right. \\
& \quad \times \left. \prod_{m+1 \leq i < j \leq N} \prod_{0 \leq s \leq r-2} (x_i - t^{-s\alpha_{1,r-1}} x_j) f(x_1, \dots, x_N) \prod_{m+1 \leq i < j \leq N} \frac{(x_i - tx_j)}{(x_i - x_j)} \right).
\end{aligned}$$

Thus, if we extract the symmetric factors of the last equality and we replace in equation (5.3.6), we obtain

$$\begin{aligned}
& P_\Lambda(x_1, \dots, x_N; t^{-2/(r-1)}, t) \\
& = U_I^- \left(\prod_{1 \leq i < j \leq m} \prod_{0 \leq s \leq r-2} (x_i - t^{-s\alpha_{1,r-1}} x_j) \prod_{i=1}^m \prod_{j=m+1}^N \prod_{0 \leq s \leq r-2} (x_i - t^{-s\alpha_{1,r-1}} x_j) \right. \\
& \quad \times \prod_{m+1 \leq i < j \leq N} \prod_{0 \leq s \leq r-2} (x_i - t^{-s\alpha_{1,r-1}} x_j) \prod_{m+1 \leq i < j \leq N} (x_i - tx_j) \\
& \quad \left. \times S_J \left(\prod_{m+1 \leq i < j \leq N} (x_i - x_j)^{-1} f(x_1, \dots, x_N) \right) \right). \quad (5.3.7)
\end{aligned}$$

Now, formula (5.2.2) allows to express U_I^- in terms of the symmetrization operator acting in the first m variables, so we have

$$\begin{aligned}
& U_I^- \left(\prod_{1 \leq i < j \leq m} \prod_{0 \leq s \leq r-2} (x_i - t^{-s\alpha_{1,r-1}} x_j) \prod_{i=1}^m \prod_{j=m+1}^N \prod_{0 \leq s \leq r-2} (x_i - t^{-s\alpha_{1,r-1}} x_j) \right) \\
& = \prod_{1 \leq i < j \leq m} (x_i - t^{-1} x_j) S_I \left(\prod_{1 \leq i < j \leq m} \prod_{0 \leq s \leq r-2} (x_i - t^{-s\alpha_{1,r-1}} x_j) \right. \\
& \quad \left. \times \prod_{i=1}^m \prod_{j=m+1}^N \prod_{0 \leq s \leq r-2} (x_i - t^{-s\alpha_{1,r-1}} x_j) \prod_{1 \leq i < j \leq m} (x_i - x_j)^{-1} \right).
\end{aligned}$$

Once again, if we extract the symmetric factors of the last equality and we replace in equation (5.3.7), we obtain

$$\begin{aligned} P_\Lambda(x_1, \dots, x_N; t^{-2/(r-1)}, t) &= \prod_{1 \leq i < j \leq N} \prod_{0 \leq s \leq r-2} (x_i - t^{-s\alpha_{1,r-1}} x_j) \prod_{m+1 \leq i < j \leq N} (x_i - t x_j) \\ &\times S_I \left(\prod_{1 \leq i < j \leq m} \frac{(x_i - t^{-1} x_j)}{(x_i - x_j)} S_J \left(\prod_{m+1 \leq i < j \leq N} (x_i - x_j)^{-1} f(x_1, \dots, x_N) \right) \right) \end{aligned}$$

and the proposition follows. \square

Corollary 5.3.7. *Let $k = 1$, r be positive and even and denote $\alpha_{1,r} = -\frac{2}{r-1}$. Then*

$$P_{((r-1)\delta_N; \emptyset)}(x_1, \dots, x_N; t^{-2/(r-1)}, t) = \prod_{1 \leq i < j \leq N} \prod_{0 \leq s \leq r-2} (x_i - t^{-s\alpha_{1,r-1}} x_j).$$

Proof. We have by definition that $P_{(\lambda; \emptyset)}(x_1, \dots, x_N; q, t) = U_{1, \dots, N}^- E_\lambda(x_1, \dots, x_N; q, t)$. Then, by using Corollary 5.3.5 and noting that the product of the factors in equation (5.3.5) is t -antisymmetric, we get the result. \square

Corollary 5.3.8. *Let $\Lambda = (\delta_m; 0^{N-m})$ be a superpartition. Then,*

$$P_{(\delta_m; 0^{N-m})}(x_1, \dots, x_N; q, t) = \prod_{1 \leq i < j \leq m} (x_i - t^{-1} x_j).$$

Theorem 5.3.9. *Let $k = 1$, r be positive and even and denote $\alpha_{1,r} = -\frac{2}{r-1}$. Let also Λ be a superpartition of bi-degree $(n|m)$ with $\ell(\Lambda) \leq N$. If Λ is moderately $(1, r, N)$ -admissible, then*

i)

$$\begin{aligned} P_\Lambda^{\text{SA}}(x_1, \dots, x_N; t^{-2/(r-1)}, t) &= \prod_{1 \leq i < j \leq N} \prod_{0 \leq s \leq r-2} (x_i - t^{-s\alpha_{1,r-1}} x_j) \\ &\times \prod_{1 \leq i < j \leq m} (x_i - t x_j) Q(x) \end{aligned}$$

ii)

$$P_{\Lambda}^{\text{SS}}(x_1, \dots, x_N; t^{-2/(r-1)}, t) = \prod_{1 \leq i < j \leq N} \prod_{0 \leq s \leq r-2} (x_i - t^{-s\alpha_{1,r-1}} x_j) \\ \times \prod_{1 \leq i < j \leq m} (x_i - tx_j) \prod_{m+1 \leq i < j \leq N} (x_i - tx_j) Q(x).$$

In the above equations, $Q(x_1, \dots, x_N)$ denotes some polynomial, which varies from one symmetry type to another.

In the following proposition, we recall the special clustering property given in [1, Proposition 2] and furthermore we enunciate this result for the Macdonald polynomial with prescribed symmetry of type AA.

Proposition 5.3.10. *Let $\Lambda = (\delta_m; \mu)$ be a superpartition and μ a partition such that $\mu_1 \leq m - 1$. Then,*

$$i) P_{(\delta_m; \mu)}^{\text{AS}}(x_1, \dots, x_N; q, t) = \prod_{1 \leq i < j \leq m} (x_i - t^{-1}x_j) P_{(\emptyset; \mu)}^{\text{AS}}(x_{m+1}, \dots, x_N; qt, t) \\ ii) P_{(\delta_m; \mu)}^{\text{AA}}(x_1, \dots, x_N; q, t) = \prod_{1 \leq i < j \leq m} (x_i - t^{-1}x_j) P_{(\emptyset; \mu)}^{\text{AA}}(x_{m+1}, \dots, x_N; qt, t)$$

Proof. The case i) was proved in [1] and the proof of case ii) is similar to the proof for case i). \square

Corollary 5.3.11. *Let $\Lambda = (\delta_m; \mu)$ be a superpartition and μ a partition such that $\mu_1 \leq m - 1$. Then,*

$$P_{(\delta_m; \mu)}(x_1, \dots, x_N; \alpha) = \prod_{1 \leq i < j \leq m} (x_i - x_j) P_{(\emptyset; \mu)}(x_{m+1}, \dots, x_N; \alpha + 1)$$

where $P_{\Lambda}(x; \alpha)$ denotes the Jack polynomial with prescribed symmetry of type AS.

5.3.3 CLUSTERINGS PROPERTIES FOR $k \geq 1$

In this subsection we get a criterion that allows to determine when a composition as in (5.2.4) and any permutation of this composition (see (5.2.5)) belongs to Kasatani's set $B^{(k,r)}$, for a given k and r . This result is of fundamental importance to prove the general $k > 1$ clustering property for Macdonald polynomials with prescribed symmetry.

Proposition 5.3.12. *Let $\eta = (\lambda^+, \mu^+)$ be a composition as in (5.2.4) and let Λ be its associated superpartition, i.e., $\varphi_m(\eta) = (\Lambda^*, \Lambda^\circledast)$. If Λ is moderately (k, r, N) -admissible, then η belongs to $B^{(k,r)}$ and moreover, for any γ obtained by a permutation of η as in (5.2.5), we have that γ also belongs to $B^{(k,r)}$.*

Proof. First, we show that η belongs to $B^{(k,r)}$ using that Λ is its associated superpartition. By definition η belongs to $B^{(k,r)}$ if and only if for all $i = 1, \dots, N - k$, we have $\eta_{i_a} - \eta_{i_{a+k}} \geq r$ or $\eta_{i_a} - \eta_{i_{a+k}} = r - 1$ if $i_a < i_{a+k}$. The indexes are determined as follows: $(i_1, \dots, i_n) = \omega \cdot (1, \dots, n)$ where ω is the shortest element in S_n such that $\eta = \omega \cdot \eta^+$ and where η^+ is the associated partition to η . Now, since $\Lambda^* = \eta^+$, we can rewrite the conditions above: η belongs to $B^{(k,r)}$ iff for all $i = 1, \dots, N - k$, we have $\Lambda_i^* - \Lambda_{i+k}^* \geq r$ or $\Lambda_i^* - \Lambda_{i+k}^* = r - 1$ if $l < j$, where $\varphi(\eta_l) = \Lambda_i^*$ and $\varphi(\eta_j) = \Lambda_{i+k}^*$.

Fix $i \in \{1, \dots, N - k\}$. We analyze two cases:

- i) $\Lambda_{i+k}^\circledast = \Lambda_{i+k}^* + 1$. By hypothesis we know that Λ is moderately (k, r, N) -admissible, i.e., $\Lambda_i^\circledast - \Lambda_{i+k}^\circledast \geq r$, for all $1 \leq i \leq N - k$, but since $\Lambda_{i+k}^\circledast = \Lambda_{i+k}^* + 1$, we get $\Lambda_i^\circledast - \Lambda_{i+k}^* \geq r + 1$, which implies $\Lambda_i^* - \Lambda_{i+k}^* \geq r$. Thus, we conclude that η belongs to $B^{(k,r)}$. Furthermore, for any γ obtained by a permutation of η as in (5.2.5), we have that γ and η have the same associated superpartition. Hence, we conclude that γ also belongs to $B^{(k,r)}$.
- ii) $\Lambda_{i+k}^\circledast = \Lambda_{i+k}^*$. By hypothesis we have that $\Lambda_i^\circledast - \Lambda_{i+k}^\circledast \geq r$, for all $1 \leq i \leq N - k$, but since $\Lambda_{i+k}^\circledast = \Lambda_{i+k}^*$, we get $\Lambda_i^\circledast - \Lambda_{i+k}^* \geq r$. Now, we have to analyze two possible cases: $\Lambda_i^\circledast = \Lambda_i^*$ and $\Lambda_i^\circledast = \Lambda_i^* + 1$.

If $\Lambda_i^\circledast = \Lambda_i^*$ we get $\Lambda_i^* - \Lambda_{i+k}^* \geq r$, so we conclude $\eta \in B^{(k,r)}$. Following the same argument given in case i) we conclude that γ also belongs to $B^{(k,r)}$. On the other hand, if $\Lambda_i^\circledast = \Lambda_i^* + 1$ we get $\Lambda_i^* - \Lambda_{i+k}^* \geq r - 1$. However, by the assumption $\Lambda_{i+k}^\circledast = \Lambda_{i+k}^*$ we know that $\Lambda_{i+k}^* = \varphi(\eta_j)$ for some $j \in \{m + 1, \dots, N\}$, while to require $\Lambda_i^\circledast = \Lambda_i^* + 1$, we know that $\Lambda_i^* = \varphi(\eta_l)$ for some $l \in \{1, \dots, m\}$. So, we have $\eta_l - \eta_j \geq r - 1$ with $l < j$, which implies $\eta \in B^{(k,r)}$. Following the argument that η and γ have the same associated superpartition and using the definition of the permutation γ (see (5.2.5)), we obtain that $\Lambda_i^* = \varphi(\gamma'_l)$ and $\Lambda_{i+k}^* = \varphi(\gamma'_j)$ for some $l' \in \{1, \dots, m\}$ and $j' \in \{m + 1, \dots, N\}$. Thus, we conclude that $\gamma \in B^{(k,r)}$.

□

Remark 5.3.13. Let $\eta = (\lambda^+, \mu^+)$ be a composition as in (5.2.4) and Λ its associated superpartition. We can prove easily that if Λ is weakly (k, r, N) -admissible, then η belongs to $B^{(k,r)}$. However, it is not true that for any composition γ obtained by a permutation of η as in (5.2.5), γ belongs to $B^{(k,r)}$.

For example, by taking $k = 1$, $r = 2$, $N = 2$ and $\eta = (1, 0)$, we see that $(1, 0; \emptyset)$ is weakly $(1, 2, 2)$ -admissible and $\eta = (1, 0) \in B^{(1,2)}$, i.e., $E_\eta(x_1, x_2; t^{-2}, t)$ is divisible by $tx_1 - x_2$. However, $\gamma = (0, 1) \notin B^{(1,2)}$ and we can check that $E_\gamma(x_1, x_2; t^{-2}, t) = x_2$, so it is not divisible by $tx_1 - x_2$. Despite the above, the Macdonald polynomial with prescribed symmetry $P_{(1,0;\emptyset)}$ satisfies the clustering property $P_{(1,0;\emptyset)}(x_1, x_2; t^{-2}, t) = \frac{tx_1 - x_2}{t}$.

Proposition 5.3.14. Let $k > 1$ and r be positive integers with $\gcd(k+1, r-1) = 1$, $\alpha = -(k+1)/(r-1)$ and let $\Lambda = (\Lambda_1, \dots, \Lambda_m; \Lambda_{m+1}, \dots, \Lambda_N)$ be a superpartition of bi-degree $(n|m)$ and such that $N \geq k+m+1$. If Λ is moderately (k, r, N) -admissible, then $P_\Lambda(x; q, t)$ vanishes at

$$q^{r-1}t^{k+1} = 1 \quad \text{and} \quad x_{i_{a+1}} = x_{i_a} t^{1+\alpha s_a}, \quad 1 \leq a \leq k, \quad i_a \geq m+1$$

for all non-negative integers $i_1, \dots, i_{k+1}, s_1, \dots, s_k$ such that

$$\text{all } i_a \text{ are distinct, } \sum_{a=1}^k s_a \leq r-2, \quad \text{and} \quad i_a < i_{a+1} \text{ if } s_a = 0.$$

Proof. Let $\eta = (\Lambda_1, \dots, \Lambda_m, \Lambda_{m+1}, \dots, \Lambda_N)$ be the associated composition to Λ . According to Proposition (5.2.18), we have

$$P_\Lambda(x; q, t) = \sum_{\gamma=\omega(\eta)} \hat{c}_{\eta\gamma} E_\gamma(x; q, t) \quad (5.3.8)$$

for $\omega = \sigma \times \sigma'$ and $\sigma \in S_m$, $\sigma' \in S_{N-m}$. By the argument used in the proof of Proposition 5.2.5, we know that if Λ is moderately (k, r, N) -admissible, then each summand $\hat{c}_{\eta\gamma} E_\gamma(x; q, t)$ has no poles at the specialization $q^{r-1}t^{k+1} = 1$.

Furthermore, Proposition 5.3.12 establishes that each $\gamma = \omega(\eta)$ in (5.3.8) belongs to $B^{(k,r)}$, and thus each one of the summands $E_\gamma(x; q, t)$ vanishes when

$$q^{r-1}t^{k+1} = 1 \quad \text{and} \\ x_{i_{a+1}} = x_{i_a} t^{1+\alpha s_a}, \quad 1 \leq a \leq k, \quad i_a \geq m+1, \quad s_1 + \dots + s_k \leq r-2,$$

and the proposition follows. \square

Corollary 5.3.15 (Clustering property). *Let Λ be a moderately (k, r, N) -admissible superpartition of bi-degree $(n|m)$ and such that $N \geq k + m + 1$. Assume $\alpha = -(k+1)/(r-1)$. Then the Jack polynomial with prescribed symmetry of type AS or SS satisfies the following clustering property:*

$$P_\Lambda(x_1, \dots, x_{N-k}, \overbrace{z, \dots, z}^{k \text{ times}}; \alpha) = \prod_{j=m+1}^{N-k} (x_j - z)^{r-1} Q(x_1, \dots, x_{N-k}, z)$$

for some polynomial Q in $N - k + 1$ variables.

Proof. Let $P_\Lambda(x; q, t)$ be the Macdonald polynomial with prescribed symmetry. According to Proposition 5.2.3, we have

$$P_\Lambda(x; q, t) = \sum_{\gamma=\omega(\eta)} \hat{c}_{\eta\gamma} E_\gamma(x; q, t) \tag{5.3.9}$$

and moreover, by Proposition 5.2.5, we know that if Λ is a moderately (k, r, N) -admissible superpartition, then $P_\Lambda(x; q, t)$ is regular under the specialization $q = t^\alpha$, where $\alpha = -(k+1)/(r-1)$. Since the non-symmetric Jack polynomials can be recovered from the non-symmetric Macdonald polynomials through the specialization $q = t^\alpha$ when $t \rightarrow 1$ and each term in the last expansion is regular at this specialization, then we can specialize term to term. So,

$$P_\Lambda(x; q, t)|_{q=t^\alpha} \longrightarrow P_\Lambda(x; \alpha) \quad \text{when } t \rightarrow 1.$$

On the other hand, by Proposition 5.3.14, we know that if Λ is moderately (k, r, N) -admissible, then $P_\Lambda(x; q, t)$ vanishes at $q = t^\alpha$ for $\alpha = -(k+1)/(r-1)$ and

$$x_{i_{a+1}} = x_{i_a} t^{1+\alpha s_a}, \quad 1 \leq a \leq k, \quad i_a \geq m+1, \quad s_1 + \dots + s_k \leq r-2.$$

In particular, if the variables x_{N-k+1}, \dots, x_N are specialized as

$$x_{N-k+i} = t^{1+\alpha s_i} x_{N-k+i-1}, \quad 2 \leq i \leq k$$

the polynomial $P_\Lambda(x; t^\alpha, t)$ is divisible by

$$\prod_{i=1}^k (x_{N-k+i} - t^{i+\alpha(s_1+\dots+s_i)} x_{N-k}), \quad \text{for all } s_1 + \dots + s_k \leq r - 2$$

so, when we specialize these k -variables as z , the polynomial

$$P_\Lambda(x_1, \dots, x_{N-k}, \overbrace{z, \dots, z}^{k \text{ times}}; \alpha)$$

is divisible by

$$\prod_{i=1}^k (z - t^{i+\alpha(s_1+\dots+s_i)} x_{N-k}), \quad \text{for all } s_1 + \dots + s_k \leq r - 2.$$

In the limit $t \rightarrow 1$ the last product simplifies to $(z - x_{N-k})^{r-1}$. Now, since the polynomial $P_\Lambda(x; \alpha)$ is symmetric in the last $N - m$ variables, then the polynomial $P_\Lambda(x_1, \dots, x_{N-k}, \overbrace{z, \dots, z}^{k \text{ times}}; \alpha)$ is divisible by $\prod_{j=m+1}^{N-k} (z - x_j)^{r-1}$, i.e., the result is independent of the specialized variables, and the corollary follows. \square

APPENDIX A

RECURSIVE FORMULA FOR NON-SYMMETRIC JACK POLYNOMIALS

In [47], Knop and Sahi defined the creation operators for the non-symmetric Jack polynomials: $\Phi := x_n s_{n-1} s_{n-2} \dots s_1$, where s_i is the transposition that exchanges x_i and x_{i+1} . They proved the following result (see [47, Corollary 4.2]):

Let $\lambda \in \mathbb{N}^n$ with $\lambda_n \neq 0$ and $\lambda^* := (\lambda_n - 1, \lambda_1, \dots, \lambda_{n-1})$, then $E_\lambda = \Phi(E_{\lambda^*})$.

The polynomials given below were generated by using the previous result and [4, Eq. (2.21)].

Table A.1: Non-symmetric Jack polynomials of degree $n \leq 2$.

Composition η	Non-symmetric Jack polynomial $E_\eta(x; \alpha)$
(0, 0, 0)	1
(0, 0, 1)	x_3
(0, 1, 0)	$x_2 + \frac{1}{\alpha+2}x_3$
(1, 0, 0)	$x_1 + \frac{1}{\alpha+1}x_2 + \frac{1}{\alpha+1}x_3$
(0, 1, 1)	x_2x_3
(1, 0, 1)	$x_1x_3 + \frac{1}{\alpha+2}x_2x_3$
(1, 1, 0)	$x_1x_2 + \frac{1}{\alpha+1}x_1x_3 + \frac{1}{\alpha+1}x_2x_3$
(0, 0, 2)	$x_3^2 + \frac{1}{\alpha+1}x_1x_3 + \frac{1}{\alpha+1}x_2x_3$
(0, 2, 0)	$x_2^2 + \frac{1}{2(\alpha+1)}x_3^2 + \frac{1}{\alpha+1}x_1x_2 + \frac{1}{2(\alpha+1)^2}x_1x_3 + \frac{2\alpha+3}{2(\alpha+1)^2}x_2x_3$
(2, 0, 0)	$x_1^2 + \frac{1}{2\alpha+1}x_2^2 + \frac{1}{2\alpha+1}x_3^2 + \frac{2}{2\alpha+1}x_1x_2 + \frac{2}{2\alpha+1}x_1x_3 + \frac{2}{(2\alpha+1)(\alpha+1)}x_2x_3$

APPENDIX B

TRIANGULARITY OF JACK POLYNOMIALS WITH PRESCRIBED SYMMETRY

In this appendix, we provide tables that exemplify the triangular decomposition of the Jack polynomials with prescribed symmetry in the monomials basis.

Table B.1: Jack polynomials with symmetry AS and degree $n \leq 3$

Superpartition Λ	Jack polynomial of type AS $P_\Lambda(x; \alpha)$
(0)	$m_{(0)}$
(1)	$m_{(1)}$
(1, 1)	$m_{(1,1)}$
(2)	$m_{(2)} + \frac{2}{\alpha+1}m_{(1,1)}$
(1, 1, 1)	$m_{(1,1,1)}$
(2, 1)	$m_{(2,1)} + \frac{6}{\alpha+2}m_{(1,1,1)}$
(3)	$m_{(3)} + \frac{3}{2\alpha+1}m_{(2,1)} + \frac{6}{(\alpha+1)(2\alpha+1)}m_{(1,1,1)}$

Superpartition Λ	Jack polynomial of type AS $P_\Lambda(x; \alpha)$
(0; 0)	$m_{(0;0)}$
(0; 1)	$m_{(0;1)}$
(1; 0)	$m_{(1;0)} + \frac{1}{\alpha+1}m_{(0;1)}$
(0; 1, 1)	$m_{(0;1,1)}$
(1; 1)	$m_{(1;1)} + \frac{2}{\alpha+2}m_{(0;1,1)}$
(0; 2)	$m_{(0;2)} + \frac{2}{\alpha+1}m_{(0;1,1)} + \frac{1}{\alpha+1}m_{(1;1)}$
(2; 0)	$m_{(2;0)} + \frac{1}{2\alpha+1}m_{(0;2)} + \frac{2}{(\alpha+1)(2\alpha+1)}m_{(0;1,1)} + \frac{2}{2\alpha+1}m_{(1;1)}$
(0; 1, 1, 1)	$m_{(0;1,1,1)}$
(1; 1, 1)	$m_{(1;1,1)} + \frac{3}{\alpha+3}m_{(0;1,1,1)}$
(0; 2, 1)	$m_{(0;2,1)} + \frac{6}{\alpha+2}m_{(0;1,1,1)} + \frac{2}{\alpha+2}m_{(1;1,1)}$
(1; 2)	$m_{(1;2)} + \frac{1}{\alpha+1}m_{(0;2,1)} + \frac{6}{(\alpha+1)(\alpha+2)}m_{(0;1,1,1)} + \frac{2}{\alpha+1}m_{(1;1,1)}$
(2; 1)	$m_{(2;1)} + \frac{(\alpha+2)}{2(\alpha+1)^2}m_{(0;2,1)} + \frac{3}{(\alpha+1)^2}m_{(0;1,1,1)} + \frac{1}{\alpha+1}m_{(1;2)} + \frac{(2\alpha+3)}{(\alpha+1)^2}m_{(1;1,1)}$
(0; 3)	$m_{(0;3)} + \frac{3}{2\alpha+1}m_{(0;2,1)} + \frac{6}{(\alpha+1)(2\alpha+1)}m_{(0;1,1,1)} + \frac{2}{2\alpha+1}m_{(1;2)} + \frac{4}{(\alpha+1)(2\alpha+1)}m_{(1;1,1)}$ $+ \frac{1}{2\alpha+1}m_{(2;1)}$
(3; 0)	$m_{(3;0)} + \frac{1}{3\alpha+1}m_{(0;3)} + \frac{3}{(2\alpha+1)(3\alpha+1)}m_{(0;2,1)} + \frac{6}{(2\alpha+1)(3\alpha+1)(\alpha+1)}m_{(0;1,1,1)}$ $+ \frac{3(\alpha+1)}{(2\alpha+1)(3\alpha+1)}m_{(1;2)} + \frac{6}{(2\alpha+1)(3\alpha+1)}m_{(1;1,1)} + \frac{3}{3\alpha+1}m_{(2;1)}$
(1, 0; 0)	$m_{(1,0;0)}$
(1, 0; 1)	$m_{(1,0;1)}$
(2, 0; 0)	$m_{(2,0;0)} + \frac{1}{\alpha+1}m_{(1,0;1)}$
(1, 0; 1, 1)	$m_{(1,0;1,1)}$
(1, 0; 2)	$m_{(1,0;2)} + \frac{2}{\alpha+2}m_{(1,0;1,1)}$
(2, 0; 1)	$m_{(2,0;1)} + \frac{1}{\alpha+1}m_{(1,0;2)} + \frac{2}{\alpha+1}m_{(1,0;1,1)}$
(2, 1; 0)	$m_{(2,1;0)} + \frac{-\alpha}{2(\alpha+1)^2}m_{(1,0;2)} + \frac{1}{(\alpha+1)^2}m_{(1,0;1,1)} + \frac{1}{\alpha+1}m_{(2,0;1)}$
(3, 0; 0)	$m_{(3,0;0)} + \frac{1}{2\alpha+1}m_{(1,0;2)} + \frac{2}{(\alpha+1)(2\alpha+1)}m_{(1,0;1,1)} + \frac{2}{2\alpha+1}m_{(2,0;1)} + \frac{1}{2\alpha+1}m_{(2,1;0)}$
(2, 1, 0; 0)	$m_{(2,1,0;0)}$

APPENDIX C

SETS OF CELLS ASSOCIATED TO SUPERPARTITIONS

In this appendix we illustrate the sets associated to the diagram of a superpartition introduced in Chapter 3. Let us consider the diagram

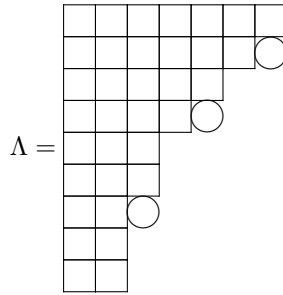

Below, we have marked the cells belonging to $\text{BF}(\Lambda)$, the set of cells belonging simultaneously to a bosonic row (without circle) and a fermionic column (with circle):

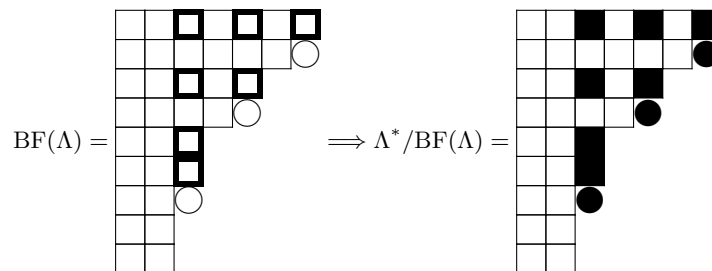

In the diagrams below, we have marked the cells belonging to $\text{FF}(\Lambda)$, the set of cells belonging to a fermionic row and a fermionic column, while $\text{FF}^*(\Lambda) = \text{FF}(\Lambda) \setminus \{s \mid s \in \Lambda^\otimes/\Lambda^*\}$,

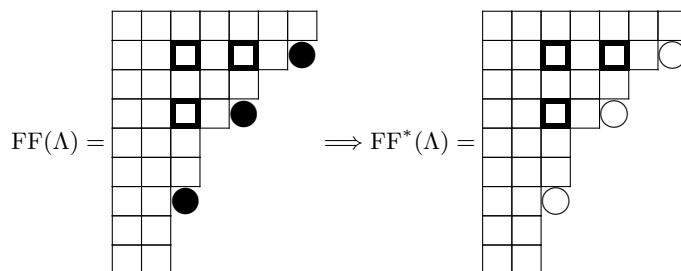

Finally, we have marked the cells belonging to the set $BRDB$ that contains all cells (i, j) such that i is a bosonic row and j is the length of some other bosonic row i' satisfying $\Lambda_i^* > \Lambda_{i'}^*$

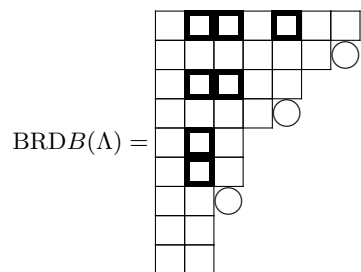

APPENDIX D

CLUSTERING FOR NON-SYMMETRIC JACK POLYNOMIALS

In this appendix, we provide basic examples that illustrate how clusters are formed in non-symmetric Jack polynomials.

For $r = 2$, $m = 1$ and $N = 3$

κ	δ	$\kappa + (r - 1)\delta'$	$E_{\kappa+(r-1)\delta'}(x; 2/r - 1)$	$E_{\kappa}(x; 2/r - 1)$
(1, 2, 0)	(2, 1, 0)	(2, 4, 0)	$-\prod_{1 \leq i < j \leq 3} (x_i - x_j)E_{\kappa}(x; 2)$	$\frac{1}{18}(18x_1x_2^2 + 7x_1x_2x_3 + 3x_1x_3^2 + 6x_3x_2^2 + x_2x_3^2)$
(0, 2, 0)	(2, 1, 0)	(1, 4, 0)	$-\prod_{1 \leq i < j \leq 3} (x_i - x_j)E_{\kappa}(x; 2)$	$\frac{1}{18}(6x_1x_2 + x_1x_3 + 18x_2^2 + 7x_2x_3 + 3x_3^2)$

For $r = 2$, $m = 2$ and $N = 4$

κ	δ	$\kappa + (r - 1)\delta'$	$E_{\kappa+(r-1)\delta'}(x; 2/r - 1)$	$E_{\kappa}(x; 2/r - 1)$
(1, 1, 2, 0)	(3, 2, 1, 0)	(3, 2, 5, 0)	$\prod_{1 \leq i < j \leq 4} (x_i - x_j)E_{\kappa}(x; 2)$	$\frac{1}{21}(21x_1x_2x_3^2 + 8x_1x_2x_3x_4 + 3x_1x_4^2x_2 + 7x_4x_3^2x_1 + x_1x_3x_4^2 + 7x_2x_3^2x_4 + x_2x_3x_4^2)$
(1, 0, 2, 0)	(3, 2, 1, 0)	(3, 1, 5, 0)	$\prod_{1 \leq i < j \leq 4} (x_i - x_j)E_{\kappa}(x; 2)$	$\frac{1}{21}(x_1x_4x_2 + 7x_1x_2x_3 + 3x_1x_4^2 + 8x_4x_3x_1 + 21x_1x_3^2 + 7x_2x_3^2 + 4x_2x_3x_4 + x_4^2x_2 + 7x_4x_3^2 + x_3x_4^2)$

For $r = 2$, $m = 3$ and $N = 5$

κ	δ	$\kappa + (r - 1)\delta'$	$E_{\kappa+(r-1)\delta'}(x; 2/r - 1)$	$E_{\kappa}(x; 2/r - 1)$
(1, 1, 1, 2, 0)	(4, 3, 2, 1, 0)	(4, 3, 2, 6, 0)	$-\prod_{1 \leq i < j \leq 5} (x_i - x_j) E_{\kappa}(x; 2)$	$\frac{1}{24}(24x_2x_1x_3x_4^2 + 8x_2x_1x_4^2x_5 + 3x_2x_1x_3x_5^2$ $+ 8x_1x_3x_4^2x_5 + 8x_2x_3x_4^2x_5 + 9x_2x_1x_3x_4x_5$ $+ x_2x_4x_3x_5^2 + x_4x_1x_3x_5^2 + x_2x_1x_4x_5^2)$
(1, 1, 0, 2, 0)	(4, 3, 2, 1, 0)	(4, 3, 1, 6, 0)	$-\prod_{1 \leq i < j \leq 5} (x_i - x_j) E_{\kappa}(x; 2)$	$\frac{1}{48}(16x_1x_2x_3x_4 + 2x_1x_3x_2x_5 + 18x_1x_4x_2x_5$ $+ 6x_1x_5^2x_2 + 16x_1x_3x_4^2 + 48x_1x_4^2x_2 + 2x_1x_3x_5^2$ $+ 16x_1x_4^2x_5 + 2x_4x_1x_5^2 + 9x_1x_3x_5x_4 + x_3x_4x_5^2$ $+ 8x_3x_4^2x_5 + 16x_2x_3x_4^2 + 2x_2x_3x_5^2 + 16x_2x_4^2x_5$ $+ 2x_2x_4x_5^2 + 9x_2x_3x_4x_5)$

APPENDIX E

EXAMPLES OF ADMISSIBLE AND INVARIANT SUPERPARTITIONS

In this appendix, for the triplet (k, r, N) given below, we display all smallest possible (k, r, N) -admissible superpartitions that lead to Jack polynomials with prescribed symmetry \mathcal{AS} that are translationally invariant and, as a consequence, admit clusters of size k and order r . The word “smallest” refers to the least number of boxes in the corresponding diagrams.

Let $(k, r, N) = (4, 3, 15)$. Suppose first that the number m of circle is zero. Then, according to Corollary 4.3.14, the smallest possible partition that is (k, r, N) -admissible and indexes an invariant polynomial is $\lambda = (9^3, 6^4, 3^4)$. For higher values of m , one obtains the smallest superpartitions by deleting some squared corners in λ and adding circles while keeping conditions C1 and C2 satisfied. All smallest superpartitions for $(k, r, N) = (4, 3, 15)$ are given below.

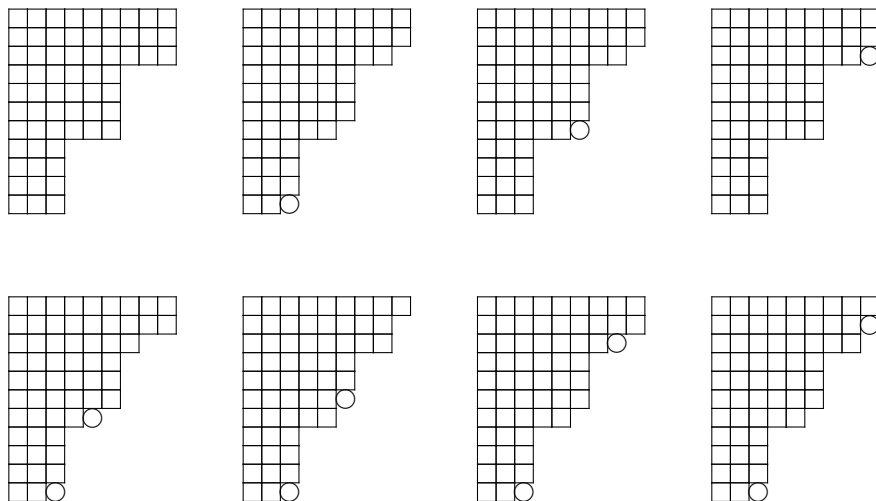

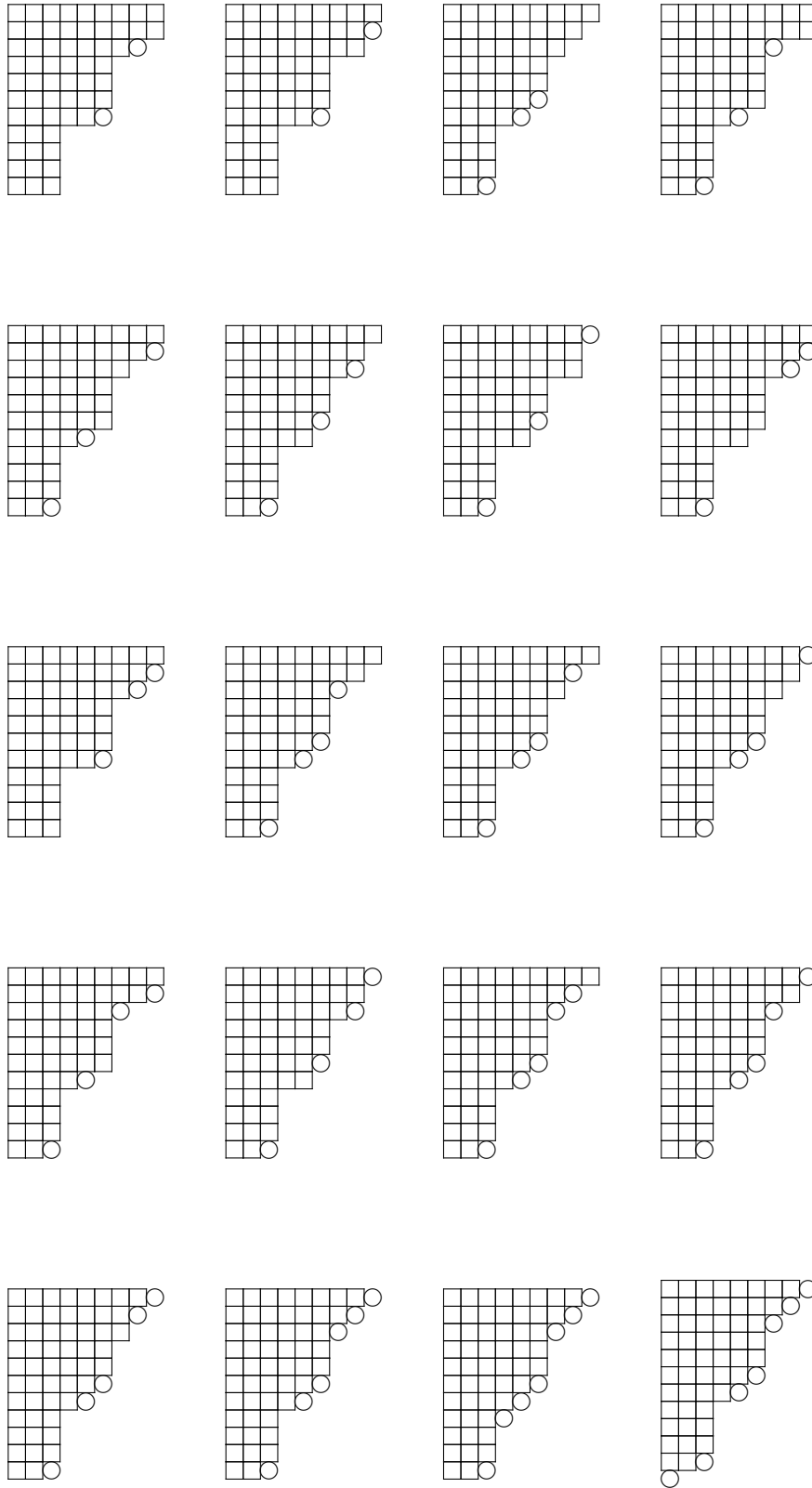

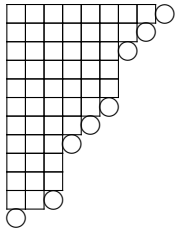

APPENDIX F

RECURSIVE FORMULA FOR NON-SYMMETRIC MACDONALD POLYNOMIALS

The non-symmetric Macdonald polynomials can be generated recursively. For instance, with the help of [3, Corollary 4.2], we can easily obtain the explicit expansions given in the following table.

Table F.1: Non-symmetric Macdonald polynomials of degree $n \leq 2$

Composition η	Non-symmetric Macdonald polynomial $E_\eta(x; q, t)$
(0, 0, 0)	1
(0, 0, 1)	x_3
(0, 1, 0)	$x_2 + \frac{tq(t-1)}{-1+t^2q}x_3$
(1, 0, 0)	$x_1 + \frac{q(t-1)}{-1+tq}x_2 + \frac{q(t-1)}{-1+tq}x_3$
(0, 1, 1)	x_2x_3
(1, 0, 1)	$x_1x_3 + \frac{tq(t-1)}{-1+t^2q}x_2x_3$
(1, 1, 0)	$x_1x_2 + \frac{q(t-1)}{-1+tq}x_1x_3 + \frac{q(t-1)}{-1+tq}x_2x_3$
(0, 0, 2)	$x_3^2 + \frac{t-1}{-1+tq}x_1x_3 + \frac{t-1}{-1+tq}x_2x_3$
(0, 2, 0)	$x_2^2 + \frac{(t-1)tq^2}{t^2q^2-1}x_3^2 + \frac{t-1}{-1+tq}x_1x_2 + \frac{(t-1)^2tq^2}{(-1+tq)^2(tq+1)}x_1x_3 + \frac{q(t-1)(t^2q+t^2q^2-tq-1)}{(-1+tq)^2(tq+1)}x_2x_3$
(2, 0, 0)	$x_1^2 + \frac{(t-1)q^2}{-1+tq^2}x_2^2 + \frac{(t-1)q^2}{-1+tq^2}x_3^2 + \frac{q(t-1)(q+1)}{-1+tq^2}x_1x_2 + \frac{q(t-1)(q+1)}{-1+tq^2}x_1x_3 + \frac{q^2(t-1)^2(q+1)}{(-1+tq^2)(-1+tq)}x_2x_3$

APPENDIX G

EXPANSION OF MACDONALD POLYNOMIALS WITH PRESCRIBED SYMMETRY IN TERMS OF NON-SYMMETRIC MACDONALD POLYNOMIALS

The formula that allows to write down explicitly the Macdonald polynomials with prescribed symmetry of type AS as a linear combination of non-symmetric Macdonald polynomials is given in (5.2.6). The examples given below were generated with the help of this formula.

Table G.1: Macdonald polynomials with prescribed symmetry AS of degree $n \leq 3$ and $N = 3$

Superpartition Λ	Macdonald polynomial with prescribed symmetry $P_\Lambda(x; q, t)$
(0, 0, 0)	$E_{(0,0,0)}$
(1, 0, 0)	$E_{(1,0,0)} + \frac{1-q}{1-tq} E_{(0,1,0)} + \frac{1-q}{1-t^2q} E_{(0,0,1)}$
(1, 1, 0)	$E_{(1,1,0)} + \frac{1-q}{1-tq} E_{(1,0,1)} + \frac{1-q}{1-t^2q} E_{(0,1,1)}$
(2, 0, 0)	$E_{(2,0,0)} + \frac{1-q^2}{1-tq^2} E_{(0,2,0)} + \frac{1-q^2}{1-t^2q^2} E_{(0,0,2)}$
(1, 1, 1)	$E_{(1,1,1)}$
(2, 1, 0)	$E_{(2,1,0)} + \frac{1-q}{1-tq} E_{(2,0,1)} + \frac{1-q}{1-tq} E_{(1,2,0)} + \frac{(1-q)(1-tq^2)}{(1-tq)(1-t^2q^2)} E_{(1,0,2)} + \frac{(1-q)(1-tq^2)}{(1-tq)(1-t^2q^2)} E_{(0,2,1)} + \frac{(1-q)^2(1-tq^2)}{(1-tq)^2(1-t^2q^2)} E_{(0,1,2)}$
(3, 0, 0)	$E_{(3,0,0)} + \frac{1-q^3}{1-tq^3} E_{(0,3,0)} + \frac{1-q^3}{1-t^2q^3} E_{(0,0,3)}$

Superpartition Λ	Macdonald polynomial with prescribed symmetry $P_\Lambda(x; q, t)$
(0; 0, 0)	$E_{(0,0,0)}$
(0; 1, 0)	$E_{(0,1,0)} + \frac{1-tq}{1-t^2q} E_{(0,0,1)}$
(1; 0, 0)	$E_{(1,0,0)}$
(0; 1, 1)	$E_{(0,1,1)}$
(1; 1, 0)	$E_{(1,1,0)} + \frac{1-q}{1-tq} E_{(1,0,1)}$
(0; 2, 0)	$E_{(0,2,0)} + \frac{1-tq^2}{1-t^2q^2} E_{(0,0,2)}$
(2; 0, 0)	$E_{(2,0,0)}$
(0; 1, 1, 1)	$E_{(0,1,1,1)}$
(1; 1, 1)	$E_{(1,1,1)}$
(0; 2, 1)	$E_{(0,2,1)} + \frac{1-q}{1-tq} E_{(0,1,2)}$
(1; 2, 0)	$E_{(1,2,0)} + \frac{1-tq^2}{1-t^2q^2} E_{(1,0,2)}$
(2; 1, 0)	$E_{(2,1,0)} + \frac{1-q}{1-tq} E_{(2,0,1)}$
(0; 3, 0)	$E_{(0,3,0)} + \frac{1-tq^3}{1-t^2q^3} E_{(0,0,3)}$
(3; 0, 0)	$E_{(3,0,0)}$
(1, 0; 0)	$E_{(1,0,0)} - \frac{1-t^2q}{t(1-tq)} E_{(0,1,0)}$
(1, 0; 1)	$E_{(1,0,1)} - \frac{1-t^3q}{t(1-t^2q)} E_{(0,1,1)}$
(2, 0; 0)	$E_{(2,0,0)} - \frac{1-t^2q^2}{t(1-tq^2)} E_{(0,2,0)}$
(1, 0; 1, 1)	$E_{(1,0,1,1)} - \frac{1-t^4q}{t(1-t^3q)} E_{(0,1,1,1)}$
(1, 0; 2)	$E_{(1,0,2)} - \frac{1-t^2q}{t(1-tq)} E_{(0,1,2)}$
(2, 0; 1)	$E_{(2,0,1)} - \frac{1-t^3q^2}{t(1-t^2q^2)} E_{(0,2,1)}$
(2, 1; 0)	$E_{(2,1,0)} - \frac{1-t^2q}{t(1-tq)} E_{(1,2,0)}$
(3, 0; 0)	$E_{(3,0,0)} - \frac{1-t^2q^3}{t(1-tq^3)} E_{(0,3,0)}$
(2, 1, 0; 0)	$E_{(2,1,0,0)} - \frac{1-t^2q}{t(1-tq)} E_{(2,0,1,0)} - \frac{1-t^2q}{t(1-tq)} E_{(1,2,0,0)} + \frac{(1-t^2q)(1-t^3q^2)}{t^2(1-tq)(1-t^2q^2)} E_{(1,0,2,0)}$ $+ \frac{(1-t^2q)(1-t^3q^2)}{t^2(1-tq)(1-t^2q^2)} E_{(0,2,1,0)} - \frac{(1-t^2q)^2(1-t^3q^2)}{t^3(1-tq)^2(1-t^2q^2)} E_{(0,1,2,0)}$

BIBLIOGRAPHY

- [1] T.H. Baker, C.F. Dunkl, and P.J. Forrester, *Polynomial eigenfunctions of the Calogero-Sutherland-Moser models with exchange terms*, pages 37–42 in J. F. van Diejen and L. Vinet, *Calogero-Sutherland-Moser Models*, CRM Series in Mathematical Physics, Springer (2000).
- [2] T.H. Baker and P.J. Forrester, *Generalized weight functions and the Macdonald polynomials*. arXiv preprint q-alg/9603005 (1996).
- [3] T.H. Baker and P.J. Forrester, *A q -analogue of the type A Dunkl operator and integral kernel*. International Mathematics Research Notices 14 (1997), 667-686.
- [4] T.H. Baker and P.J. Forrester, *The Calogero-Sutherland model and polynomials with prescribed symmetry*, Nuclear Physics B 492.3 (1997): 682–716.
- [5] T.H. Baker and P.J. Forrester, *Isomorphisms of type A affine Hecke algebras and multivariable orthogonal polynomials*. Pacific Journal of Mathematics 194.1 (2000), 19–41.
- [6] W. Baratta, *Pieri-type formulas for nonsymmetric Macdonald polynomials*. International Mathematics Research Notices 2009.15 (2009), 2829–2854.
- [7] W. Baratta, *Some properties of Macdonald polynomials with prescribed symmetry*, Kyushu Journal of Mathematics 64.2 (2010), 323–343.
- [8] W. Baratta and P.J. Forrester, *Jack polynomial fractional quantum Hall states and their generalizations*, Nuclear Physics B 843.1 (2011), 362–381.
- [9] W. Baratta, *Special Function Aspects of Macdonald Polynomial Theory*, Doctoral Thesis, The University of Melbourne (2011).

-
- [10] W. Baratta, *Computing nonsymmetric and interpolation Macdonald polynomials*. arXiv preprint arXiv:1201.4450 (2012).
- [11] C. Berkesch, S. Griffeth, S.V. Sam, and Zamaere, *Jack Polynomials as Fractional Quantum Hall States and the Betti Numbers of the $(k + 1)$ -Equals Ideal*, Communications in Mathematical Physics (2014), 1–20.
- [12] D. Bernard, M. Gaudin, F.D. Haldane, and V. Pasquier, *Yang-Baxter equation in long range interacting system*, Journal of Physics A: Mathematical and General 26.20 (1993), 5219.
- [13] B.A. Bernevig and F.D. Haldane, *Fractional quantum Hall states and Jack polynomials*, Physical review letters 100.24 (2008): 246802; *Generalized Clustering Conditions of Jack Polynomials at Negative Jack Parameter α* , Physical Review B 77.18 (2008), 184502.
- [14] O. Blondeau, P. Desrosiers, L. Lapointe, and P. Mathieu, *Macdonald polynomials in superspace: conjectural definition and positivity conjectures*. Letters in Mathematical Physics 101.1 (2012), 27–47.
- [15] O. Blondeau, P. Desrosiers, L. Lapointe, and P. Mathieu, *Macdonald polynomials in superspace as eigenfunctions of commuting operators*. arXiv preprint arXiv:1202.3922 (2012).
- [16] O. Blondeau, P. Desrosiers, L. Lapointe, and P. Mathieu, *Double Macdonald polynomials as the stable limit of Macdonald superpolynomials*. arXiv preprint arXiv:1211.3186 (2012).
- [17] I. Cherednik, *Nonsymmetric Macdonald polynomials*. International Mathematics Research Notices 1995.10 (1995), 483–515.
- [18] I. Cherednik, *Double affine Hecke algebras*. Vol. 319. Cambridge University Press, 2005.
- [19] S. Corteel and J. Lovejoy, *Overpartitions*, Transactions of the American Mathematical Society 356.4 (2004), 1623–1635.
- [20] P. Desrosiers, and J. Gatica, *Jack polynomials with prescribed symmetry and some of their clustering properties*. arXiv:1308.4932 (2013), 47 pages. To be published in Annales Henri Poincaré (2014), 65 pages.

-
- [21] P. Desrosiers, L. Lapointe, and P. Mathieu, *Jack superpolynomials, superpartition ordering and determinantal formulas*. Communications in mathematical physics 233.3 (2003): 383–402.
- [22] P. Desrosiers, L. Lapointe, and P. Mathieu, *Jack polynomials in superspace*, Communications in mathematical physics 242.1-2 (2003), 331–360.
- [23] P. Desrosiers, L. Lapointe, and P. Mathieu, *Orthogonality of Jack polynomials in superspace*, Advances in Mathematics 212.1 (2007), 361–388.
- [24] P. Desrosiers, L. Lapointe, and P. Mathieu, *Classical symmetric functions in superspace*, Journal of Algebraic Combinatorics 24.2 (2006), 209–238.
- [25] P. Desrosiers, L. Lapointe, and P. Mathieu, *Evaluation and normalization of Jack polynomials in superspace*, International Mathematics Research Notices 2012.23 (2012), 5267–5327.
- [26] P. Desrosiers, L. Lapointe, and P. Mathieu, *Jack Superpolynomials with Negative Fractional Parameter: Clustering Properties and Super-Virasoro Ideals*, Communications in Mathematical Physics 316.2 (2012), 395–440.
- [27] C.F. Dunkl, *Orthogonal polynomials of types A and B and related Calogero models*, Communications in mathematical physics 197.2 (1998), 451–487.
- [28] C.F. Dunkl, J.-G. Luque, *Clustering properties of rectangular Macdonald polynomials*, arXiv:1204.5117 (2012), 43 pages.
- [29] B. Estienne and R. Santachiara, *Relating Jack wavefunctions to WA_{k-1} theories*, Journal of Physics A: Mathematical and Theoretical 42.44 (2009), 445209.
- [30] B. Estienne, N. Regnault and R. Santachiara, *Clustering properties, Jack polynomials and unitary conformal field theories*. Nuclear physics B 824.3 (2010), 539–562.
- [31] B. Feigin, M. Jimbo, T. Miwa and E. Mukhin, *A differential ideal of symmetric polynomials spanned by Jack polynomials at $\beta = -(r-1)/(k+1)$* , International Mathematics Research Notices 2002.23 (2002), 1223–1237.

- [32] B. Feigin, M. Jimbo, T. Miwa, and E. Mukhin, *Symmetric polynomials vanishing on the shifted diagonals and Macdonald polynomials*, International Mathematics Research Notices 2003.18 (2003), 1015–1034.
- [33] P.J. Forrester, *Log-gases and Random Matrices*, London Mathematical Society Monographs 34, Princeton University Press (2010).
- [34] P.J. Forrester, D.S. McAnally and Y. Nikoyalevsky, *On the evaluation formula for Jack polynomials with prescribed symmetry*, Journal of Physics A: Mathematical and General 34.41 (2001), 8407.
- [35] J. Haglund, M. Haiman, and N. Loehr, *A combinatorial formula for non-symmetric Macdonald polynomials*. American Journal of Mathematics 130.2 (2008), 359–383.
- [36] J. Haglund, *The q, t -Catalan numbers and the space of diagonal harmonics*. University Lecture Series 41 (2008).
- [37] Th. Jolicoeur and J.-G. Luque, *Highest weight Macdonald and Jack polynomials*, Journal of Physics A: Mathematical and Theoretical 44.5 (2011), 055204.
- [38] M. Kasatani, *Zeros of symmetric Laurent polynomials of type $(BC)_n$ and Koornwinder Macdonald polynomials specialized at $t^{k+1}q^{r-1} = 1$* . Compositio Mathematica 141.06 (2005), 1589–1601.
- [39] M. Kasatani, *Subrepresentations in the polynomial representation of the double affine Hecke algebra of type GL_n at $t^{k+1}q^{r+1} = 1$* , International Mathematics Research Notices 2005.28 (2005), 1717–1742.
- [40] M. Kasatani, T. Miwa, A.N. Sergeev, A.P. Veselov, *Coincident root loci and Jack and Macdonald polynomials for special values of the parameters*. Contemporary Mathematics, 417 (2006), 207.
- [41] Y. Kato and Y. Kuramoto, *Exact Solution of the Sutherland Model with Arbitrary Internal Symmetry*, Physical review letters 74.7 (1995), 1222.
- [42] Y. Kato and Y. Kuramoto, *Dynamics of One-Dimensional Quantum Systems: Inverse-Square Interaction Models*, Cambridge University Press (2009).

- [43] Y. Kato and T. Yamamoto, *Jack polynomials with prescribed symmetry and hole propagator of spin Calogero-Sutherland model*, Journal of Physics A: Mathematical and General 31.46 (1998), 9171–9184.
- [44] A. Kirillov, *Lectures on affine Hecke algebras and Macdonalds conjectures*. Bulletin of the American Mathematical Society 34.3 (1997), 251–292.
- [45] F. Knop, *Symmetric and non-symmetric quantum Capelli polynomials*. Commentarii Mathematici Helvetici 72.1 (1997), 84–100.
- [46] F. Knop, *Integrality of two variable Kostka functions*. Journal fur die Reine und Angewandte Mathematik (1997), 177–189.
- [47] F. Knop and S. Sahi, *A recursion and a combinatorial formula for Jack polynomials*, Inventiones Mathematicae 128.1 (1997), 9–22.
- [48] V.B. Kuznetsov and S. Sahi, *Jack, Hall-Littlewood and Macdonald Polynomials*. Vol. 417. American Mathematical Society, 2006.
- [49] L. Lapointe and L. Vinet, *A Rodrigues formula for the Jack polynomials and the Macdonald-Stanley conjecture*. International Mathematics Research Notices 1995.9 (1995), 419–424.
- [50] L. Lapointe and L. Vinet, *Rodrigues formulas for the Macdonald polynomials*. Advances in Mathematics 130.2 (1997), 261–279.
- [51] M. Lassalle, *Une formule du binôme généralisée pour les polynômes de Jack*, C. R. Acad. Sci. Paris Série I 310 (1990), 253–256.
- [52] M. Lassalle, *Coefficients binomiaux généralisés et polynômes de Macdonald*, J. Funct. Anal. 158 (1998), 289–324.
- [53] I.G. Macdonald, *Symmetric Functions and Hall Polynomials* (2nd ed.), Oxford University Press Inc, New York, 1995.
- [54] I.G. Macdonald, *Affine Hecke algebras and orthogonal polynomials*. Séminaire Bourbaki 37 (1996), 189–207.
- [55] D. Marshall, *Symmetric and Non-symmetric Macdonald Polynomials*, Annals of Combinatorics (1999), 385–415.

-
- [56] K. Mimachi, and M. Noumi. *A reproducing kernel for nonsymmetric Macdonald polynomials*. Duke Math. Journal. 1998.
- [57] A. Nishino, H. Ujino, and M. Wadati, *An algebraic approach to the nonsymmetric Macdonald polynomial*. Nuclear Physics B 558.3 (1999), 589–603.
- [58] E.M. Opdam, *Harmonic analysis for certain representations of graded Hecke algebras*, Acta Mathematica 175.1 (1995), 75–121.
- [59] A.P. Polychronakos, *Exchange Operator Formalism for Integrable Systems of Particles*, Physical Review Letters 69.5 (1992), 703.
- [60] A.P. Polychronakos, *The physics and mathematics of Calogero particles*, J. Phys. A 39 (2006), 12793–12845.
- [61] S. Sahi, *The binomial formula for nonsymmetric Macdonald polynomials*. Duke Math. J. 1998.
- [62] R. P. Stanley, *Some combinatorial properties of Jack symmetric functions*, Advances in Mathematics 77.1 (1989), 76–115.
- [63] R. P. Stanley, *Enumerative combinatorics*. Vol. 1. Cambridge University Press, 2011.
- [64] B. Sutherland, *Exact Results for a Quantum Many-Body Problem in One Dimension*, Physical Review A 4 (1971), 2019–2021; *Exact Results for a Quantum Many-Body Problem in One Dimension. II*, Physical Review A 5 (1972), 1372–1376.